

GAME 1210
FO 669



Skateball



SKATEBALL

Bally[®]

PINBALL DIVISION

90 O'Leary Drive, Bensenville, Illinois 60106, U.S.A.
Telephone: (312) 860-6400

© BALLY MFG. CORP. 1980
ALL RIGHTS RESERVED



GAME #1210 SKATEBALL

Installation and General Game Operation Instructions

INDEX

	PAGE
I. INSTALLATION	1
II. GENERAL GAME OPERATION	2
III. BOOKKEEPING FUNCTIONS	3
IV. FEATURE OPERATION AND SCORING	4
V. GAME ADJUSTMENTS	5
A. PLAYFIELD ADJUSTMENTS	5
B. BACKBOX ADJUSTMENTS	5
CREDITS/COIN	5
MAXIMUM CREDITS	6
BALLS/GAME	6
MATCH FEATURE OPTION	6
CREDIT DISPLAY	6
HIGH SCORE FEATURE OPTION	6
HIGH SCORE TO DATE	6
GAME FEATURE OPTIONS	7
SOUND OPTION	7
C. FRONT DOOR GAME ADJUSTMENTS	
HIGH SCORE FEATURE	8
HIGH SCORE TO DATE FEATURE	8
VI. RECOMMENDED SCORE CARDS	11
VII. RECOMMENDED SETTINGS	12
VIII. ROUTINE MAINTENANCE ON LOCATION	13
IX. TROUBLE SHOOTING ON LOCATION	13
X. SERVICE/PARTS	19
XI. PARTS LIST	20-31

BLOCK DIAGRAM—ELECTRONIC PINBALL GAME

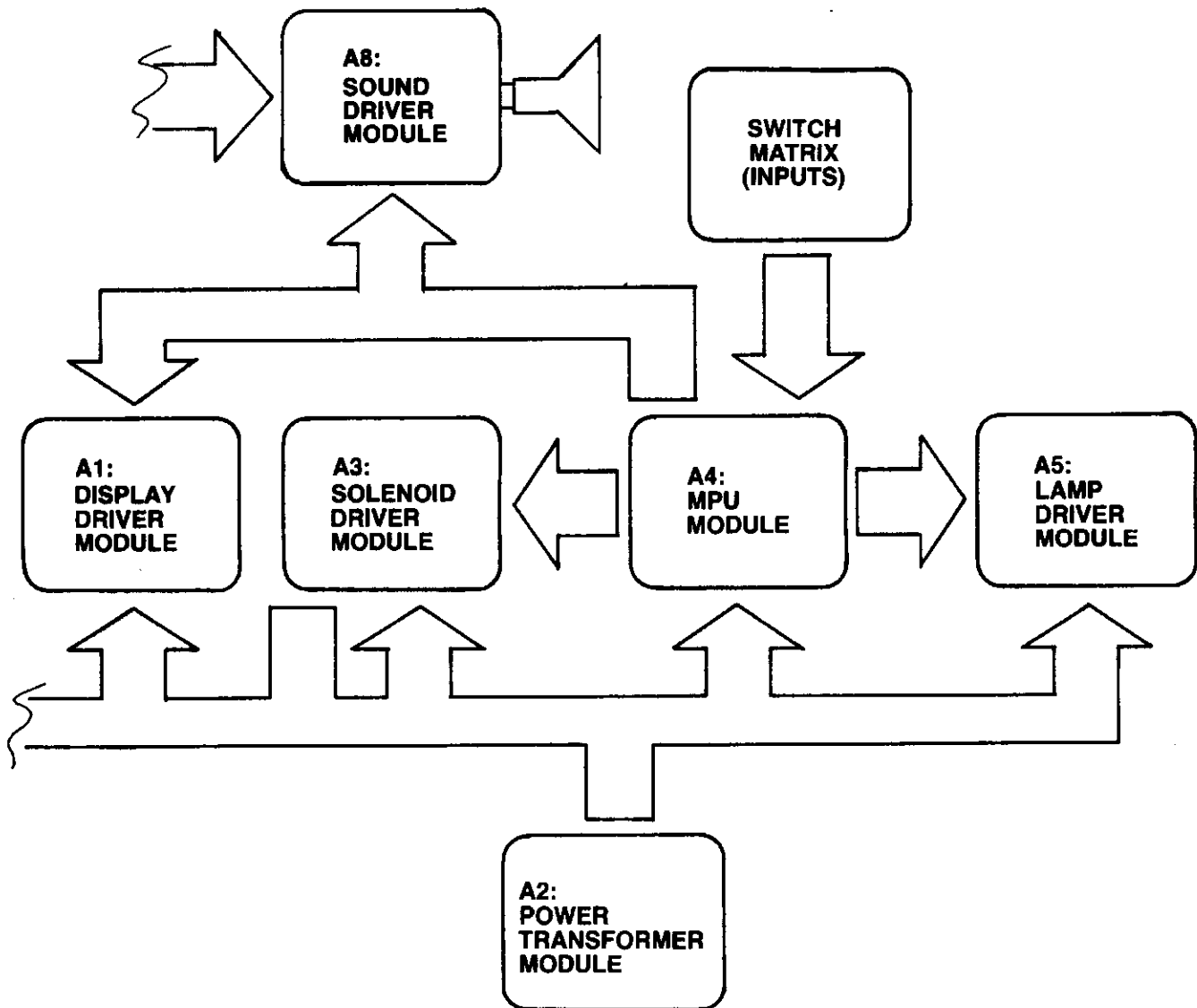

I. INSTALLATION

Assemble the game as follows:

Bolt legs to cabinet. Bolt back box to cabinet. Use flat washers under bolt heads. Gently feed cable connectors and ground braid through cable port in back box. Screw ground braid to braid in back box. Carefully and fully insert connectors on printed circuit assemblies.

On all games there are certain items that should be checked after shipment. These are visual inspections which may avoid time consuming service work later. Minor troubles caused by abusive handling in shipment are unavoidable. Cable connectors may be loosened, switches (especially tilt switches) may go out of adjustment. Plumb bob tilt switch should always be adjusted after game is set on location and leg levelers are adjusted.

Visual inspections before plugging in line cord:

1. Check that all cable connectors are completely seated on printed circuit assemblies.
2. Check that cables are clear of all moving parts.
3. Check for any wires that may have become disconnected.
4. Check switches for loose solder or other foreign material that may have come loose in shipment and could cause shorting of contacts.
5. Check wires on coils for proper soldering. Cold solder connections may not show up in factory inspection, but vibration in shipment may break contact.
6. Check that fuses are firmly seated and making good contact.
7. Check the transformer for any foreign material shorting across wiring lugs.
8. Check wiring of transformer to correspond to location voltage. See figure 1.

Check adjustment of the three (normally open) tilt switches:

1. Panel tilt on bottom of playfield panel.
2. Plumb bob tilt on left side of cabinet near front door.
3. Ball tilt above plumb bob tilt. Insert the smaller ball (15/16" dia.) into the ball tilt assembly, and adjust the bracket so the ball will roll free to contact the switch blade, if front of cabinet is raised.

TRANSFORMER CONNECTION INSTRUCTIONS

E-122-131 TRANSFORMER WIRING FOR 220/240 V.,
50/60 CYCLE INPUT.

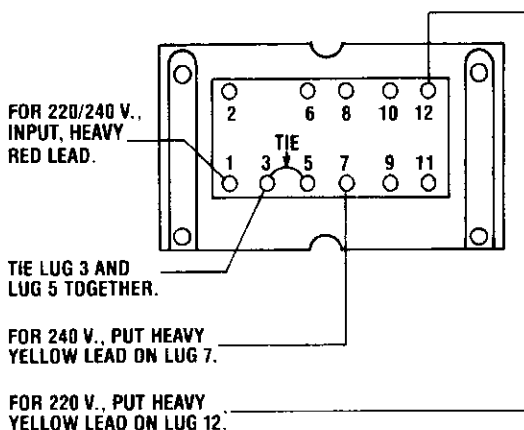

VARISTOR, BALLY PART NO. E-713-1,
LOCATED IN CABINET, MUST BE USED
FOR OPERATION AT 220 V. OR 240 V.A.C.

E-122-131 TRANSFORMER WIRING FOR 115/120 V.,
50/60 CYCLE INPUT.

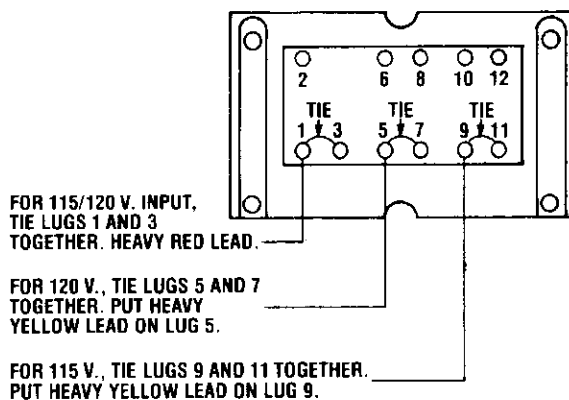

VARISTOR, BALLY PART NO. E-713,
LOCATED IN CABINET, MUST BE USED
FOR OPERATION AT 115 OR 120 V.A.C.

FIGURE I. TRANSFORMER
(PART OF POWER—TRANSFORMER MODULE A2, LOCATED IN BACK BOX).

II. GENERAL GAME OPERATION

Place ball into playfield by outhole.

Coin game. Coin should be rejected. Plug in line cord. Move power ON-OFF master switch at bottom right front corner of cabinet to 'ON' position. The game will play a power-up tune to announce game-readiness. Drop targets are reset, scores are set to zero, alternating with the 'High Score to Date,' and the game is ready for play. Coin game. The game should accept the coin and post credits* for coins accepted (adjustable). Pressing the credit button on the door will cause the outhole kicker to serve the ball to the shooter alley. The 1st player-up lite is lit. A game-up tune* is played to announce play-readiness.

One player is posted each additional time the credit button is pressed (one to four can play). The credits are reduced by one each time the credit button is pressed until the credits are reduced to zero.

Shooting the ball initiates play.

The game awards all points earned by the player. If spinner is turning and scoring when the ball hits a target, the spinner and the target scores are awarded.

When the ball enters the outhole, the bonus score is added to the total score. The player-up and/or ball in play on the back box is advanced one position. The outhole kicker serves the ball to the shooter alley and play is resumed. This continues until each player has played the allowable number of balls per game (adjustable). At this time the 'Game Over' light is lit. A random Match* number appears and the 'Match' light is lit. If the number is the same as the last two digits in a player's score, a free game is awarded.

Extra balls won during the course of the game are played immediately after the player's regular ball enters the outhole. The player-up and/or ball in play on the back box are not advanced for extra ball play. Bonus score is added to the player's score before the game serves the extra ball for play.

Scoring over 10,000,000 gives "High Score to Date" award.

At the end of the game, a 'High Score to Date' is alternately flashed with all 4 player scores. If the 'High Score to Date' is beat, this feature* awards free games.

Tilting the game results in loss of a ball. The flippers, thumper-bumpers, etc., go 'dead.' Bonus points are not scored. The purpose of the tilt penalty is to discourage the player from jostling the machine in an attempt to prolong play. Game action becomes normal after the ball kicker assembly serves the ball to the shooter alley.

Slamming the machine results in loss of the game. All feature lights go out, the game goes 'dead,' and a time delay occurs. The purpose of the time delay is to discourage unnecessary abuse of the machine. After the delay, the 'Game Over' light lites and the power-up tune is played. The time delay occurs anytime one of the slam switches is made to contact. There are two factory installed slam switches, on the front door, and one on left side of cabinet. (Any number of slam switches could be installed by the operator, to meet his individual requirement.) The switch should be adjusted to have approximately 1/16" gap between the contacts. The weighted blade should be adjusted to attain the desired sensitivity. Decreasing the gap between contacts will make the switch more sensitive. Opening the gap will reduce sensitivity.

*Some tunes and features can be disabled by operator if so desired. See Back Box Adjustments.

NOTE: Scoring and feature units will differ from game to game.

III. BOOKKEEPING FUNCTIONS

The game is designed to help the operator perform certain accounting functions. The game can display the number of total plays and replays (free games). It can display the number of coins dropped down each coin chute. The bookkeeping functions are displayed on all player score displays simultaneously. An identification number, 05 to 15, appears on the Match/Ball in Play window as follows:

- 05— 00 to— 40 = Current Credits
- *06— 10000 to— 99999 = Total Plays (Paid & Free Games)
- *07— 10000 to— 99999 = Total Replays (Free Games)
- 08— 00 to— 99999 = Game Percentage
- 09— 00 to— 99999 = Total times 'High Score to Date' is beat
- *10— 10000 to— 99999 = Coins Dropped thru Coin Chute #1
- *11— 10000 to— 99999 = Coins Dropped thru Coin Chute #2**
- *12— 10000 to— 99999 = Coins Dropped thru Coin Chute #3**
- *13— 00 to— 99999 = Number of Specials awarded from Panel Specials Only
- *14— 00 to— 99999 = Number of minutes of Game Play
- *15— 00 to— 99999 = Number of Service Credits

The game displays the first bookkeeping entry if the Self-Test button (See Fig. III) on the inside of the front door is pressed ten times. Alternately push and release the Self-Test button at one second intervals. The number 05 appears in the 'Match/Ball in Play' window. Current credits appear on the player score displays. Each additional press of the button causes the next entry to be displayed.

After the data in each bookkeeping register is recorded, it can be set to zero simply by pressing switch button S33, located on A4, the MPU module in the back box (See Fig. III), or by pressing the Coin Chute #3 switch. Any or all registers can be cleared by alternating between the Self-Test button and the switch button S33 on the MPU module or Coin Chute #3 switch. The operator is given this option as a possible convenience and can elect to use or not use it as his needs direct.

Pressing the button 5 more times causes the game to play the power-up tune and light the Game Over light.

Service credits are designed to allow the serviceman to test the game under actual play conditions without disturbing the bookkeeping records that reside at identification numbers 06, 07, 10, 11 and 12.

To obtain Service Credits, push and release the Self-Test switch until identification number 05 appears in the 'Match/Ball in Play' window. Hold in the Credit button until the desired number of Service Credits (up to five) appears on the player score displays.

NOTE: If, upon accessing identification number 05, a number of credits greater than five is displayed, pressing the credit button has no effect.

Identification number 15 is reserved as a record of the number of Service Credits used.

*The 10,000 level is pre-set at the factory; can be set to zero, initially, if desired.

**If Coin Chute is not used in game, number displayed (if other than 00) on Player Score displays has no significance.

NOTE: If "Total Play" register is reset to zeroes then "Total Replays" register should also be reset to zeroes to maintain the game percentage value.

#1210 SKATEBALL

FEATURE OPERATION & SCORING

A. BONUS SCORE FEATURE

A bonus of 1000 to 70,000 may be scored. The game starts with a bonus of 1000 points. The bonus advances one step at a time each time a drop target is knocked down, the saucer is actuated, the side rollover buttons are lit and 3 top lanes are not lit. The bonus advances two steps at a time each time the top and bottom lane rollovers are lit except the outlane rollovers which score two bonus at all times.

B. MEMORY BONUS FEATURE

When a bonus at 20,000 to 39,000, a bonus of 40,000 to 59,000, and a bonus of 60,000 to 70,000 is achieved, the respective 20,000, 40,000 and 60,000 bonus will remain in memory and be lit at the start of each ball.

C. BONUS COLLECT AND BONUS MULTIPLIERS

When the ball goes into the outhole or the saucer is lit for collect bonus the lit bonus score is added to the player's total score. If 2X, 3X, 4X or 5X is lit the score will be scored twice, three, four or five times. A tilt nullifies the bonus score.

The bonus multipliers are lit as follow: Making 1-2-3 advances the multipliers.

Right flipper button rotates 1-2-3 lanes.

Switch #23 Memory for Multipliers

ON: Liberal
OFF: Conservative

D. SPOT MULTIPLIER FEATURE

Knocking down the top drop targets twice lites the spot multiplier and the third time rewards the next higher multiplier.

Switch #8 Memory for Spot Multiplier

ON: Liberal
OFF: Conservative

E. SKATE AND A-B FEATURE

Making SKATE

1st time lites saucer for 50K and bottom button for bonus.

2nd time lites saucer for 100K and top button for bonus.

3rd time lites saucer for extra ball.

4th time lites right outlane rollover special, which alternates off slingshots and 7 rebounds.

Switch #16 Memory for Extra Ball with 50K

ON: Liberal
OFF: Conservative

Switch #24 Memory for Outlane Special with Extra Ball

ON: Liberal
OFF: Conservative

Making SKATE and A-B lites saucer for Extra Ball.

Switch #32 Memory for SKATE and A-B Extra Ball.

ON: Liberal
OFF: Conservative

Making A-B lites spinner for 1000 points.

F. CENTER DROP TARGETS FEATURE

Making all 3 drop targets can reward 10K or 20K, only flashing value can be collected. When the 2nd 20K is made the 100K will flash and can only be collected by knocking down all 3 drop targets with the ball in play.

Switch #14 Memory for center drop targets arrows.

ON: Liberal

OFF: Conservative

Making the drop targets twice with same playing ball will also lite the 100K value which can only be collected with the ball in play by knocking down all 3 drop targets.

G. THUMPER BUMPERS FEATURE

Top lanes 1-2-3 lites Thumper Bumper for 1000 points.

H. 1-2-3 SPECIAL FEATURE

Advancing the multipliers to 5X lites the 1-2-3 Special and making 1-2-3 once more scores Special.

I. BONUS SPECIAL FEATURE

Advancing bonus to 60000 lites bonus special and advancing bonus to 70,000 scores Special.

J. COLLECT BONUS FEATURE

If knocking down a top drop target with arrow flashing the arrow remains lit, lighting all 3 arrows lites the saucer for collect bonus.

Switch #15 Memory for top drop targets arrows

ON: Liberal

OFF: Conservative

K. SPECIAL REPLAY/X-BALL/NOVELTY MODES

Self test position 16 and 17 give the operator flexibility to award a replay, extra ball or score (Novelty) when a special is scored (Top lanes, left and right outlanes, bonus SPECIAL). The following chart explains the settings.

	Set ON "03"	Set ON "02"	Set ON "01"
Self test position 16	Set ON "03"	Set ON "02"	Set ON "01"
Self test position 17	<u>REPLAY</u>	<u>X-BALL</u>	<u>NOVELTY</u>
Positions	<u>REPLAY</u>	<u>X-BALL</u> *	50,000
1, 2, 3 Special	REPLAY	X-BALL*	50,000
Bonus Special	REPLAY	X-BALL*	50,000
Left or Right Out Special	REPLAY	X-BALL*	50,000
Saucer X-Ball	X-BALL	X-BALL**	25,000
Scoring Thresholds	REPLAY	X-BALL**	NO AWARD

(*) 50,000 if Same Player Shoot Again is lit.

(**) 25,000 if Same Player Shoot Again is lit.

V. GAME ADJUSTMENTS

A. Playfield Panel Post Adjustments:

Posts that control left and right outlane opening on panel can be removed to make access to outlanes easier or harder for ball to enter. See Figure II.

Easier entry will decrease playing time and scoring (conservative).
Harder entry will increase playing time and scoring (liberal).

B. Back Box Game Adjustments:

Each game has thirty-two switches located on A4, the MPU module, located in the back box, that allow play to be customized to the location. See Figure III. Credits per coin, maximum credits, credit display, balls per game, match feature, high game feature, special award and melody are selectable by means of the switches. The switches are contained in four-sixteen lead packages numbered S1-8, S9-16, S17-24, and S25-32 for easy identification. The "ON" toggle position is marked on the assembly. **Turn off power before making adjustments.**

Credits/Coin Adjustments:

The credits per coin are selectable by means of S17-S20 for coin chute #2 (Center). The switch settings and resultant credits/coin are as follows:

S20	S19	S18	S17	Credits/Coin	S20	S19	S18	S17	Credits/Coin
OFF	OFF	OFF	OFF	Same as Coin Chute #1 Settings	ON	OFF	OFF	OFF	8/1 Coin
OFF	OFF	OFF	ON	1/1 Coin	ON	OFF	OFF	ON	9/1 Coin
OFF	OFF	ON	OFF	2/1 Coin	ON	OFF	ON	OFF	10/1 Coin
OFF	OFF	ON	ON	3/1 Coin	ON	OFF	ON	ON	11/1 Coin
OFF	ON	OFF	OFF	4/1 Coin	ON	ON	OFF	OFF	12/1 Coin
OFF	ON	OFF	ON	5/1 Coin	ON	ON	OFF	ON	13/1 Coin
OFF	ON	ON	OFF	6/1 Coin	ON	ON	ON	OFF	14/1 Coin
OFF	ON	ON	ON	7/1 Coin	ON	ON	ON	ON	15/1 Coin

The credits given are selectable by means of switches 1-5 incl., for coin chute #1 and switches 9-13 incl., for coin chute #3. Thirty-one different credit ratios are available for each coin chute. The switch settings and resultant credits/coin are listed below.

CREDITS/COIN ADJUSTMENTS

COIN CHUTE #1 (HINGE SIDE) OR #3 (RIGHT SIDE)	SWITCHES					CREDITS	CREDITS	CREDITS	CREDITS	TOTAL CREDITS/COINS
	5	4	3	2	1					
	13	12	11	10	9					
	OFF	OFF	OFF	OFF	OFF	1/1 Coin				
	OFF	OFF	OFF	OFF	ON	2/1 Coin				
	OFF	OFF	OFF	ON	OFF	3/1 Coin				
	OFF	OFF	OFF	ON	ON	4/1 Coin				
	OFF	OFF	ON	OFF	OFF	5/1 Coin				
	OFF	OFF	ON	OFF	ON	6/1 Coin				
	OFF	OFF	ON	ON	OFF	7/1 Coin				
	OFF	OFF	ON	ON	ON	8/1 Coin				
	OFF	ON	OFF	OFF	OFF	9/1 Coin				
	OFF	ON	OFF	OFF	ON	12/1 Coin				
	OFF	ON	OFF	ON	OFF	14/1 Coin				
	OFF	ON	OFF	ON	ON	1/2 Coins*				
	OFF	ON	ON	OFF	OFF	2/2 Coins*				
	OFF	ON	ON	OFF	ON	3/2 Coins*				
	OFF	ON	ON	ON	OFF	4/2 Coins*				
	OFF	ON	ON	ON	ON	5/2 Coins*				
	ON	OFF	OFF	OFF	OFF	6/2 Coins*				
	ON	OFF	OFF	OFF	ON	7/2 Coins*				
	ON	OFF	OFF	ON	OFF	8/2 Coins*				
	ON	OFF	OFF	ON	ON	9/2 Coins*				
	ON	OFF	ON	OFF	OFF	12/2 Coins*				
	ON	OFF	ON	OFF	ON	14/2 Coins*				
	ON	OFF	ON	ON	OFF	1/1st Coin	2/2nd Coin			3/2
	ON	OFF	ON	ON	ON	0/1st Coin*	1/2nd Coin	1/3rd Coin	1/4th Coin	3/4
	ON	ON	OFF	OFF	OFF	0/1st Coin*	1/2nd Coin	0/3rd Coin	2/4th Coin	3/4
	ON	ON	OFF	OFF	ON	1/1st Coin	1/2nd Coin	1/3rd Coin	2/4th Coin	5/4
	ON	ON	OFF	ON	OFF	1/1st Coin	2/2nd Coin	1/3rd Coin	3/4th Coin	7/4
	ON	ON	OFF	ON	ON	1/1st Coin	2/2nd Coin	2/3rd Coin	2/4th Coin	7/4
	ON	ON	ON	OFF	OFF	1/1 Coin				
	ON	ON	ON	OFF	ON	1/1 Coin				
	ON	ON	ON	ON	OFF	1/1 Coin				
	ON	ON	ON	ON	ON	1/1 Coin				

*No Credits until second coin is dropped.

MAXIMUM CREDITS:

The maximum credits accepted by the machine limits the number of games that can be accumulated by coining, by winning replays or both. The maximum number of credits is selectable by means of switches 25 and 26. Four credit limits are available. Switch settings are listed below.

MAXIMUM CREDITS	SWITCHES	
	26	25
10	OFF	OFF
15	OFF	ON
25	ON	OFF
40	ON	ON

BALLS PER GAME:	# BALLS /GAME	SWITCHES	32	31
	5		OFF	ON
	4		ON	OFF
	3		OFF	OFF
	2		ON	ON

MATCH FEATURE:

When the Match Feature is ON, a random number appears on the Match/Ball in Play window and the word Match is illuminated. If the number matches the tens digit in a player's score, a free game is awarded. The Match Feature creates an incentive to play.

MATCH	SWITCH 28
ON	ON
OFF	OFF

CREDIT DISPLAY:	CREDITS DISPLAYED	SWITCH 27
	YES	ON
	NO	OFF

HIGH SCORE FEATURE:

The game is designed to award an Extra Ball or Free Game at each of the two or three score levels. See Front Door Game Adjustments.

AWARD	SELF TEST POSITION 16	SELF TEST POSITION 17
REPLAY	SET ON "03"	SET ON "03"
EXTRA BALL	SET ON "02"	SET ON "02"
NO AWARD	SET ON "01"	SET ON "01"

HIGH SCORE TO DATE OR OVER 10,000,000 SCORE FEATURE:

The game is designed to award free games as an option if high score to date is beat or player exceeds 10,000,000 points. Each time this happens, the winning score becomes the new high score to beat. This score is displayed on all 4 player score displays at the end of each game as an incentive to play. Recommended setting is underlined.

HIGH SCORE TO DATE FEATURE	SELF TEST POSITION 19
No Award	SET ON "00"
One Credit	SET ON "01"
Two Credits	SET ON "02"
Three Credits	SET ON "03"

State and local laws may regulate the use of the above features, and they have been designed to allow for appropriate adjustment in order to conform to such requirements.

#1210 SKATEBALL

SOUND OPTION

The game is designed to make several tones and noises to announce power-up, game-up, etc. The tones are intended to attract attention to the game and increase game usage. The tones are controlled by pressing self test button until the #18 shows on the player score displays. Now pulse replay button to desired sound setting.

Setting "00"

Playfield switches associated chimes with feature background.

Setting "01"

Playfield switches associated noises without background.

Setting "02"

Most scoring will have chime effect.

Setting "03"

Most all scoring will have a noise effect with background.

GAME FEATURE OPTIONS:

Top drop targets X lite adjustment:

Liberal

SW. 8 ON

Not making lit X will come on for next ball.

Conservative

SW. 8 OFF

Not making lit X will not come on for next ball.

Center drop targets arrow lite adjustment:

Liberal

SW. 14 ON

Not making lit arrow will come on for next ball.

Conservative

SW. 14 OFF

Not making lit arrow will not come on for next ball.

Top drop targets arrow lite adjustment:

Liberal

SW. 15 ON

Not making arrow will come on for next ball.

Conservative

SW. 15 OFF

Not making lit arrow will not come on for next ball.

50,000 and saucer extra ball lite adjustment:

Liberal

SW. 16 ON

50,000 and extra ball lite together.

Conservative

SW. 16 OFF

50,000 then extra ball will lite.

Bonus 2X thru 5X lite adjustments:

Liberal

SW. 23 ON

Any lite lit will come on for next ball.

Conservative

SW. 23 OFF

Any lite lit will not come on for next ball.

Saucer extra ball & right out special lite adjustment:

Liberal

SW. 24 ON

Saucer extra ball and right out special lite together.

Conservative

SW. 24 OFF

Saucer extra ball then right special will lite.

Saucer extra ball lite adjustment:

Liberal

SW. 30 ON

Liting A-B and S-K-A-T-E will lite saucer extra ball.

Conservative

SW. 30 OFF

Liting A-B and S-K-A-T-E will not lite saucer extra ball.

Drop targets bonus advance (both 3 bank targets):

Liberal

SW. 7 ON

Hitting any drop target advances bonus 1 step.

Conservative

SW. 7 OFF

Hitting drop targets does not advance bonus.

C. FRONT DOOR GAME ADJUSTMENTS

High Score Feature Adjustments:

The game is designed to award an extra ball (option) or a free game at each of three score levels. The recommended levels are on the score card in the game.

Any level from 10,000 to 9,999,000 can be set, as desired. It is also possible to reset or turn off (00) any or all of the levels, if desired.

1. Push and release Self-Test button (See Figure III) at one second intervals approximately six times or until identification number 01 appears on the 'Match/Ball in Play' display.
2. The number on the Player Score Displays is the score level.* It can be increased, if desired, by holding the credit button in. To decrease the score level, hold the credit button in and depress and release the Self-Test button. Release the credit button when the desired number appears. Note that the level changes 10,000 points at a time. If the number '00' is left on the displays, the high score feature is eliminated for that level.
3. Repeat steps 1 and 2 for the second and third score levels. The identification numbers '02' and '03' on the Match/Ball in Play display are for the second and third levels, respectively.

High Score to Date and 10,000,000 Feature:

The game is designed to award free games when 'High Score to Date' is beat, or if the player exceeds 10,000,000 points.

It is recommended that the level, which will build with play, be periodically reset to the factory recommended level to encourage game play. The adjustment procedure is the same as for the High Score Feature Adjustment, Steps 1 and 2. Continue pushing the Self-Test button until the identification number '04' appears on the 'Match/Ball in Play' display and then do Step 2.

Any level from '00' to 9,990,000 can be set as described. It is to be noted that '00' does NOT turn off the feature, as it does on High Score feature. The feature is turned off by positioning switches as discussed under 'Back Box Game Adjustments.'

SELF TEST SETUP FOR 16-19:

To set up positions 16-19 push and release self test button till 16 shows on player displays. Now pulse replay button for recommended setup from "00" thru "03." Repeat for positions 17, 18 or 19.

*Can be quickly set to '00' by pressing S33 on the MPU assembly in the back box or Coin Chute switch #3. (See Figure III).

#1210 SKATEBALL RUBBER RINGS

A.	R-521-3	2" DIA. (3)
B.	R-521-2	1½" DIA. (4)
C.	R-521-1	1" DIA. (4)
D.	R-521-4	2½" DIA. (3)
E.	R-521-5	3" DIA. (2)
F.	R-521	¾" DIA. (1)
G.	R-406-3	FLIPPER (3)
H.	R-243	5/16" DIA. (12)
J.	R-206-11	MINIPOST (2)

PANEL TOP PARTS

1.	Bottom Arch	P-5871-78
2.	Shooter Gauge	P-6359-44
3.	Ball Gate	A-1475-13
4.	Screened Plastics	A-2890-147
5.	Guide Rail (Red)	C-935-1 (3)
6.	Guide Rail (Red)	C-936-1 (2)
7.	Gate & Wire Assy.	ASE-2250-24
8.	Spinner & Gate Assy.	ASE-2250-80
9.	Thumper Cap	A-3713-52
10.	Ball Guide Wire	M-121-106
11.	Ball Guide Rail	A-3032-53
12.	Drop Target Assy.	ASE-2795-37
13.	Rollover Wire & Brkt.	ASE-2806-10 (5)
14.	Rollover Wire & Brkt.	ASE-2806-9
15.	Ball Guide Wire	M-121-46 (2)
16.	Ball Guide Rail	A-3032-54
17.	Rollover Button	C-900 (2)
18.	Drop Target Assy.	ASE-2795-38
19.	Ball Guide Wire	M-121-18
20.	Ball Guide Rail	A-3032-55
21.	Drop Target Assy.	ASE-2795-56
22.	Flipper & Shaft Assy.	ASE-2214-28
23.	Ball Guide Wire	M-121-56 (2)
24.	Flipper & Shaft Assy.	ASE-2214-21 (3)
25.	Ball Guide Rail	A-3032-52
26.	Gate & Wire Assy.	ASE-2250-60
27.	Gate & Wire Assy.	ASE-2250-77
28.	Ball Guide Rail	A-3032-56
29.	Ball Guide Wire	M-121-45
30.	Buffer Wire	M-121-53 (2)

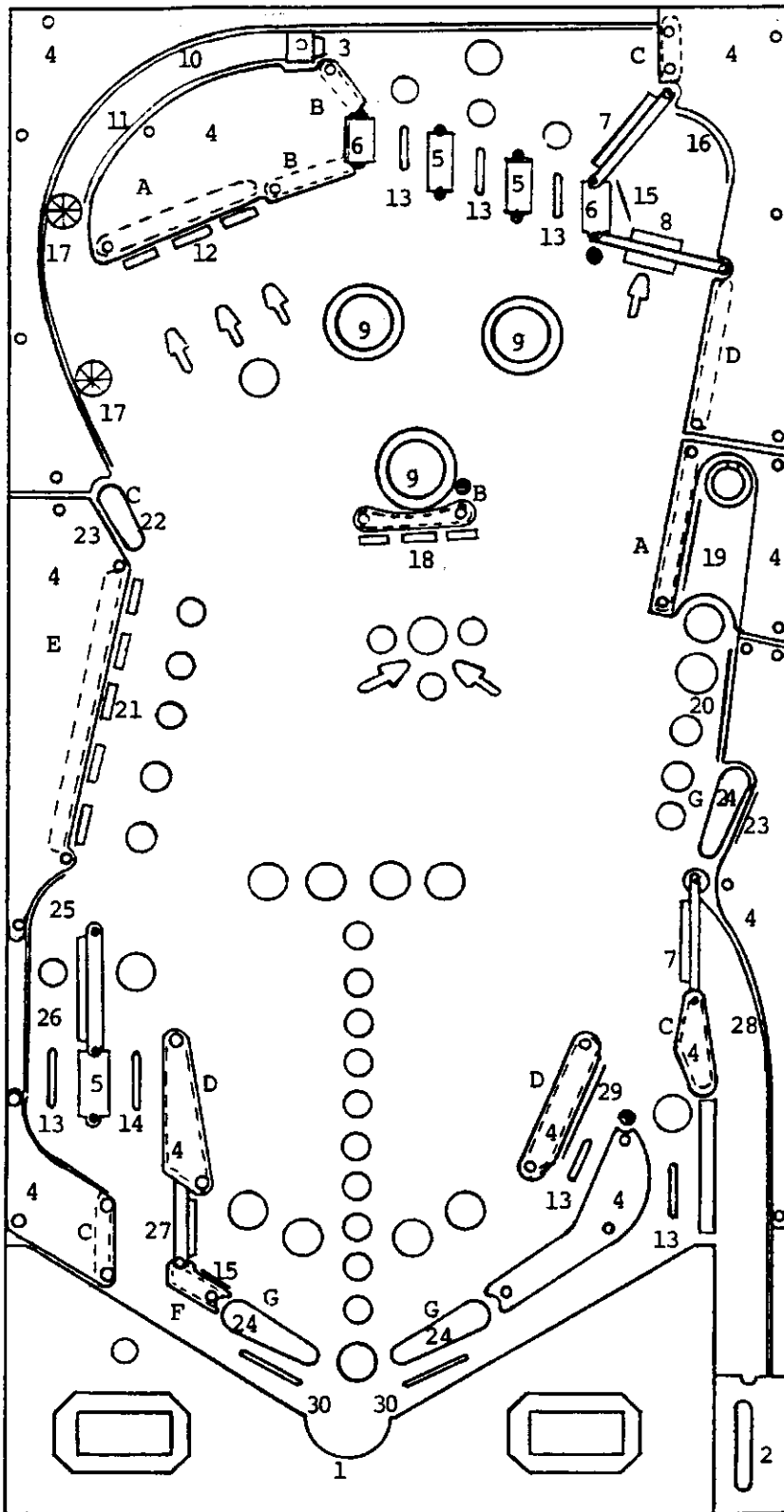

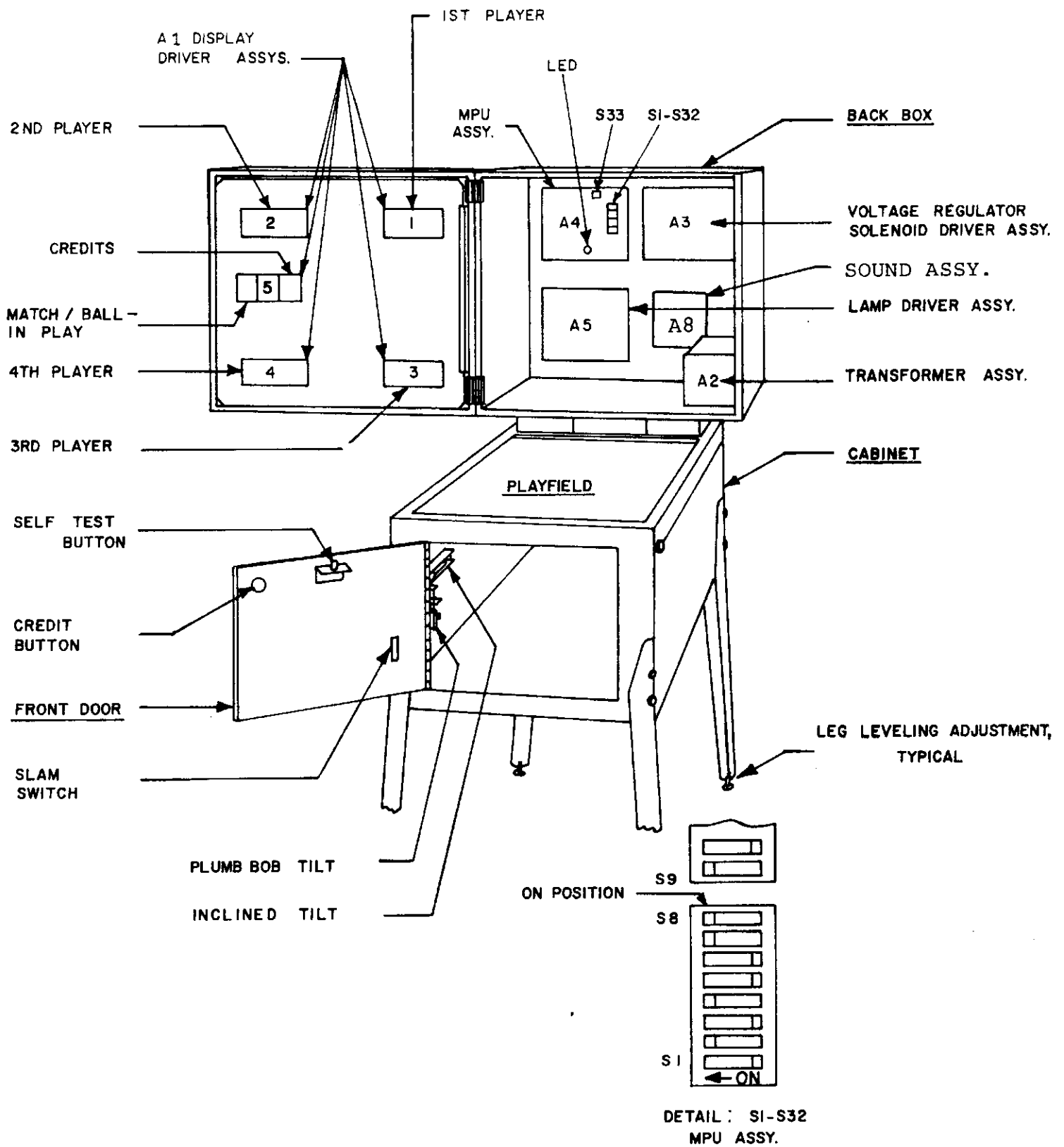

FIGURE III. ELECTRONIC PIN BALL MACHINE

RECOMMENDED

Instruction, Score Cards and High Score Feature Settings
to be used on SKATEBALL 1210

3-BALL

REPLAYS

Instruction Card M-1508-94-E
Score Card M-1508-94-B W/M
1 Replay at 600,000
1 Replay at 1100,000

5-BALL

REPLAYS

Instruction Card M-1508-94-TT
Score Card M-1508-94-A W/G
1 Replay at 800,000
1 Replay at 1400,000

EXTRA BALL

Instruction Card M-1508-94-F
Score Card M-1508-94-A W/M
1 Extra Ball at 800,000
1 Extra Ball at 1100,000
1 Extra Ball at 1400,000

ADDITIONAL CARDS

REPLAYS

M-1508-H	400,000	950,000	
M-1508-I	450,000	1,000,000	
M-1508-J	500,000	1,000,000	
M-1508-K	500,000	1,100,000	
M-1508-L	550,000	1,100,000	
M-1508-M	600,000	1,100,000	
M-1508-N	650,000	1,200,000	
M-1508-O	700,000	1,200,000	
M-1508-P	800,000	1,300,000	
M-1508-Q	800,000	1,400,000	
M-1508-R	900,000	1,400,000	
M-1508-S	900,000	1,500,000	
M-1508-T	1,000,000	1,500,000	
M-1508-U	1,100,000	1,600,000	
M-1508-V	1,200,000	1,600,000	
M-1508-W	500,000	800,000	1,100,000
M-1508-X	600,000	1,100,000	1,300,000
M-1508-Y	700,000	1,400,000	1,600,000
M-1508-Z	800,000	1,300,000	1,600,000
M-1508-AA	900,000	1,400,000	1,600,000
M-1508-AB	1,000,000	1,500,000	1,800,000

EXTRA BALL

M-1508-NN	600,000	900,000	1,200,000
M-1508-OO	800,000	1,100,000	1,400,000
M-1508-PP	900,000	1,200,000	1,400,000
M-1508-QQ	1,000,000	1,400,000	1,800,000

Instruction Card, Novelty
M-1508-94-G

Instruction Card, Replay
M-1508-94-TT

BLANKS (3)

High game to date recommended levels;
(reset periodically)
3 BALL 1,300,000
5 BALL 1,600,000

#1210 SKATEBALL

RECOMMENDED SETTINGS

RECOMMENDED REPLAY GAME SETTINGS FOR:

		3-BALL	5-BALL
BONUS ADVANCE ON BOTH "3" DROP TARGETS	SW.7	ON	OFF
SPOT MULTIPLIER RECALL	SW.8	ON	OFF
CENTER DROP TARGET ARROWS RECALL	SW.14	ON	OFF
TOP DROP TARGET ARROWS RECALL	SW.15	ON	OFF
SAUCER EXTRA BALL WITH 50K	SW.16	ON	OFF
MULTIPLIERS BONUS RECALL	SW.23	ON	OFF
SAUCER OUTLANE SPECIAL WITH EXTRA BALL	SW.24	ON	OFF
S-K-A-T-E AND A-B EXTRA BALL	SW.30	ON	OFF
BALL PER GAME	SW.31	OFF	ON
BALLS PER GAME	SW.32	OFF	OFF

3-BALL

5-BALL

REPLAY

Instruction Card	M-1508-94-E	M-1508-94-TT
Score Card	M-1508-94-B W/M	M-1508-94-W/G
Major Mode	Self Test Position 16,17 Set ON "03"	Self Test Position 16,17 Set ON "03"
Match	SW.28 ON	SW.28 ON
High Score to Date	Self Test Position 19 Set ON "03"	Self Test Position 19 Set ON "03"

X-BALL

Instruction Card		M-1508-94-F
Score Card		M-1508-94-A W/OO
Major Mode		Self Test Position 16,17 Set OFF "02"
Match		SW.28 ON
High Score to Date		Self Test Position 19 Set ON "00"

NOVELTY

Instruction Card	M-1508-94-G	M-1508-94-G
Major Mode	Self Test Position 16,17 Set ON "01"	Self Test Position 16,17 Set ON "01"
Match	SW.28 OFF	SW.28 OFF
High Score to Date	Self Test Position 19 Set ON "00"	Self Test Position 19 Set ON "000"

ADDITIONAL CARDS FOR PAGE 11

REPLAYS

M-1508-UU	480,000	720,000	M-1508-EEE	380,000	670,000	820,000
M-1508-VV	500,000	740,000	M-1508-FFF	400,000	690,000	840,000
M-1508-WW	520,000	760,000	M-1508-GGG	420,000	710,000	860,000
M-1508-XX	540,000	780,000	M-1508-HHH	440,000	730,000	880,000
M-1508-YY	560,000	800,000	M-1508-III	460,000	750,000	900,000
M-1508-ZZ	580,000	820,000	M-1508-JJJ	480,000	770,000	920,000
M-1508-AAA	600,000	840,000	M-1508-KKK	500,000	790,000	940,000
M-1508-BBB	620,000	860,000	M-1508-LLL	520,000	810,000	960,000
M-1508-CCC	640,000	880,000	M-1508-MMM	540,000	830,000	980,000
M-1508-DDD	660,000	900,000	M-1508-NNN	560,000	850,000	990,000

VIII. ROUTINE MAINTENANCE ON LOCATION:

Self-Test routines are written into the game design. They are particularly useful for routine maintenance. The tests are described below. The first test is automatic and occurs on power-up. This test causes the MPU module A4 to examine itself for failures. Seven flashes of an LED indicates proper operation. The second series of self-diagnostic tests causes the MPU to 'exercise' each of the other modules in such a way as to make their faults, if any, obvious. See Figure III and Page ii.

It is recommended that these tests be used several times a week to check out the games before play. If faults are discovered, they may be corrected on location if the operator has a stock of replacement modules. See "Trouble Shooting on Location."

MPU Module Self-Test:

At power on, the LED on the MPU module flashes once. (Flicker-Flash). After a pause, it flashes six more times and goes out. A power-up tune is played to announce game readiness. This indicates proper MPU operating condition and successful completion of the power-up test.

Game Self-Diagnostic Tests:

1. Pressing the Self-Test button inside the door initiates the Self-Test routine. See Figures III and IV. All switched lamps flash off and on continuously.
2. Pressing the Self-Test button again causes each digit on each display to cycle from 0 thru 9, and repeat continuously.
3. Pressing the Self-Test button again causes each solenoid to be energized, one at a time, in a continuous sequence. Hold both flipper buttons 'in' during this test. The number appearing on the Player Score displays is the same as the number assigned to the solenoid. The sound of a solenoid pulling-in as a number appears indicates proper operation. The absence of sound is improper. If sound is absent, see Page 17 for help in Solenoid identification.
4. Pressing Self-Test button again causes the sound module to play the "Game Over" tune repeatedly.
5. Pressing the Self-Test button again causes the MPU to search each switch assembly for stuck contacts. If any are found, the number of the first set encountered is flashed on the Player Score displays. The number remains until the fault is cleared. See Page 17 for help in Stuck Switch identification. Other numbers may follow if more stuck contacts are present. If there are no stuck switches, the Match/Ball in Play display flashes '0'.
6. Pressing the Self-Test button 20 more times causes the MPU to step thru the threshold and bookkeeping functions described previously and finally to repeat the power-up test. For more rapid exit to power-up, turn the game off, then on. The game is now ready to play.

After successful completion of the Self Diagnostic Test procedure, set the game up for play. Exercise each rollover, thumper-bumper, slingshot, etc., by hand until each switch assembly on the playfield has been checked for proper operation. If actuating a switch assembly results in intermittent or no response, clean contacts by gently closing them on a clean business card or piece of paper and wiping until they wipe clean. Regap, if necessary, to 1/16". **Do not burnish or file Gold Plated Switch Contacts.**

IX. TROUBLESHOOTING ON LOCATION

The game is designed to make troubleshooting easy. Several simple procedures are given herein that cover the greatest percentage of game failures. They are written for an operator on location and require module replacement. (See Figure III) Symptoms and the action to be taken are given for each type of problem.

If the problem is more complicated and is not solved by following this procedure, more detailed procedures are available from Bally. See the Parts List for ordering information.

FIGURE IV SELF DIAGNOSTIC TEST

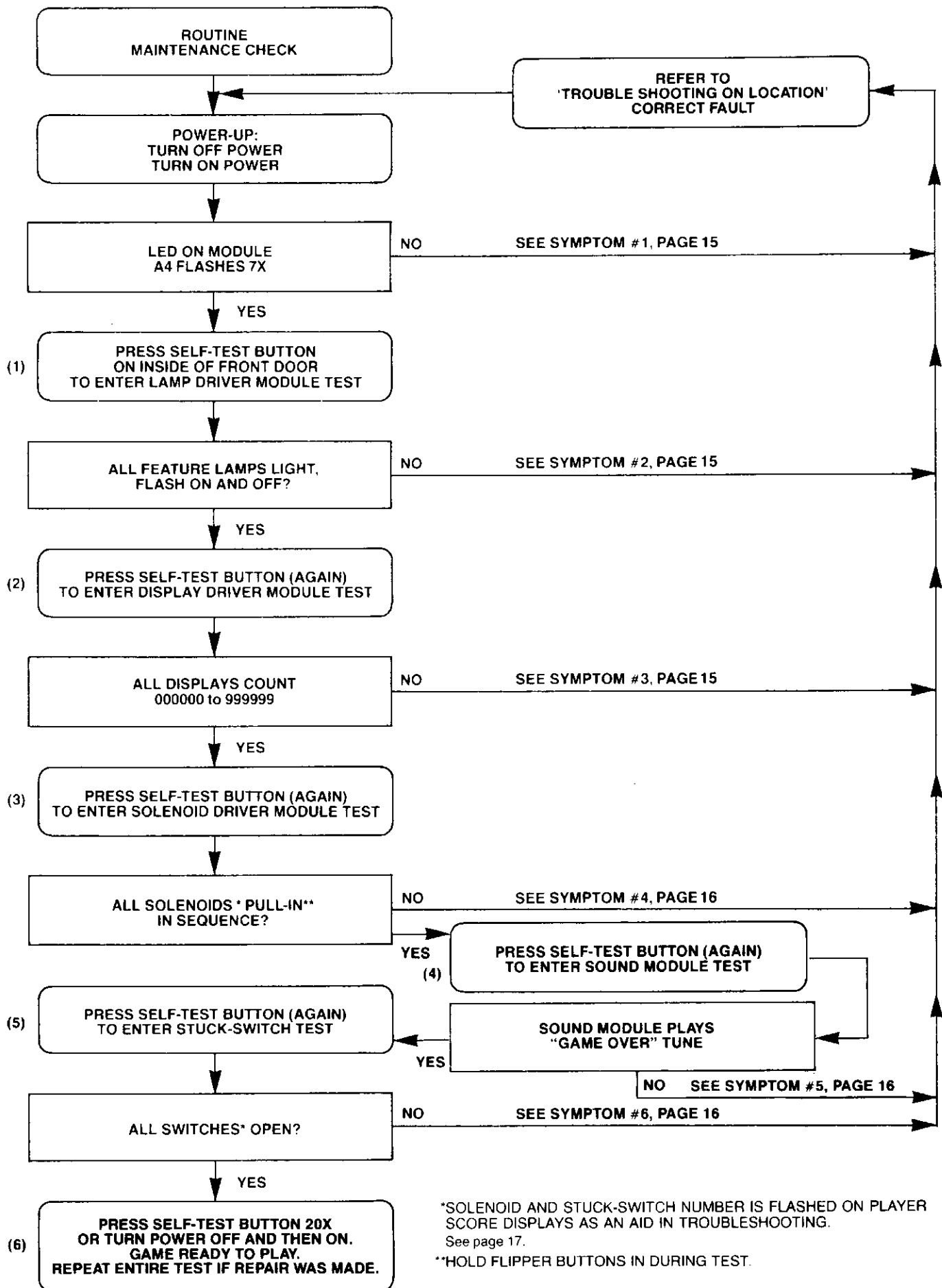

*SOLENOID AND STUCK-SWITCH NUMBER IS FLASHED ON PLAYER SCORE DISPLAYS AS AN AID IN TROUBLESHOOTING.

See page 17.

**HOLD FLIPPER BUTTONS IN DURING TEST.

- 1A) SYMPTOM:** Game does not play power-up tune when power is turned on. General Illumination is present.
- ACTION:**
- A)** Turn power OFF. Open back box. Locate light emitting diode (LED) on MPU module A4.
 - B)** Turn Power ON. LED must flash 7X to indicate that module A4 is good. Correct flash sequence is flicker/flash-pause-and then six more flashes and LED goes out.
 - C.** If LED does not come on, or does not flash, or flashes, but less than 7X, turn off power. Replace MPU module A4.
- CAUTION:** **Replacement MPU Module must have same Part Number or incorrect operation will result! See Parts List for MPU Module Part Number.**
- Turn power ON.
- D)** If game is correct, it is now ready for play. If game is not correct, refer to Module Replacement procedure. (See Parts List.)
- 2A) SYMPTOM:** Not all feature lamps light during game play.
- ACTION:**
- A)** With power ON, open front door. Press button (Self-Test switch) once. If the game is correct, **all** feature lamps flash ON and OFF.
 - B)** Carefully raise playfield or open back box to gain access to lamps.
 - C)** Replace bulbs that do not flash.
 - D)** If game is correct, it is now ready for play.
 - E)** If game is not correct, turn power OFF. Replace Lamp Driver Module A5. Turn power ON and repeat A.
 - F)** If game is correct, it is now ready for play.*
 - G)** If game is not correct, turn power OFF. Replace MPU module A4. See CAUTION, 1C. Turn power ON and repeat A.
 - H)** If game is correct, it is now ready for play.* If game is not correct, refer to Module Replacement procedure. (See Parts List.)
- 2B) SYMPTOM:** One or some switched lamps always ON.
- ACTION:** Repeat 2AA, AB, AE, and AF and, if necessary AG & AH.
- 3A) SYMPTOM:** Display digits improper on **one** or **several**, but less than all Display Driver module(s), A1. Improper: One or several segments always OFF, digits mottled or several segments or digit(s) always ON.
- ACTION:**
- A)** With power ON, open front door. Press button (Self-Test switch) twice. If the game is correct, each digit on each Display Driver Module A1 (5 used/game) displays the count 1-9 and 0 continuously in all 6 digit positions. Note defective Display Driver modules.
 - B)** Turn power OFF.
- CAUTION: High Voltage is supplied to the Display Driver Modules, A1, from the Solenoid Driver/Voltage Regulator Module A3. Wait 30 seconds for High Voltage to Bleed Off.**
- C)** Replace Display Driver module(s) A1. Turn power ON. Repeat A.
 - D)** If game is correct, it is now ready to play.* If game is not correct, refer to Module Replacement procedure. (See Parts List.)
- 3B) SYMPTOM:** **All** displays improper (all five display Driver modules). Improper: Digit(s) always on or off/segment(s) always on or off, all displays.
- ACTION:**
- A)** Repeat 3AA, and AB.
 - B)** Replace MPU module A4. See CAUTION NOTE, 1C. Turn power ON. Repeat A.

- C) If game is correct, it is now ready to play.* If game is not correct, refer to Module Replacement procedure. (See Parts List.)
- 3C) **SYMPTON:** One or several displays always off.
ACTION: A) Do 3AA, AB, AC, and AD.
 B) Repeat 3BB and BC, if necessary.
- 4A) **SYMPTOM:** Solenoid(s) do(es) not pull-in during course of game.
ACTION: A) With power ON, open front door. Press button (Self-Test switch) three times.
 B) If game was correct, each solenoid would be energized. A number is flashed on the Player Score displays as each solenoid is pulsed. Note any numbers that do not have the sound of a solenoid associated. See Solenoid Identification Table, Page 17 and Figure V.
 C) Carefully lift the playfield (or open the back box) to gain access to the solenoid. Turn power OFF. Inspect the solenoid.
 D) If a lead is broken off, repair. Repeat A & B. If game is correct, it is now ready for play.* If solenoid wiring was correct, turn power OFF.
 E) Replace Solenoid Driver/Voltage Regulator module A3. See CAUTION NOTE 3AB.
 F) Repeat AA & AB. If game is correct, it is now ready to play.* If game is not correct, turn power OFF.
 G) Replace Sound Module A8.
 H) Repeat AA and AB if game is correct. It is now ready to play. If game is not correct, turn power OFF."
 I) Replace MPU module A4. See CAUTION NOTE, 1C.
 J) Repeat A & B. If game is correct, it is now ready to play.* If game is not correct, refer to Module Replacement Procedure. (See Parts List.)
- 4B) **SYMPTOM:** Solenoid(s) always energized—Note: if impulse solenoids (ball ejects, slingshots, thumper-bumpers, etc.) are energized continuously, they are subject to damage. Limit troubleshooting to one minute with power ON, followed by **five minutes with power OFF**. Repeat as necessary. Replace damaged solenoids.
ACTION: Do 4AA, AB, AE, AF, AG, AH and if necessary, AI and AJ.
- 5) **SYMPTOM:** No Sound.
ACTION: A) With Power ON, open front door, press Self-Test switch four times.
 B) Turn volume control clockwise to Max.
 C) If correct, sound will be heard. If incorrect, try seating speaker lead connector (J2) and input connector (J1).
 D) If correct, sound will be heard. If incorrect, refer to Module Replacement procedure."
- 6) **SYMPTOM:** Feature (Drop Targets, etc.) does not score.
ACTION: A) With power ON, open front door. Press button (Self-Test switch) five times.
 B) If the game is correct, Match/Ball in Play display would flash '0'. If a number appears on the Player Score displays, see Switch Assembly Identification Table, Page 17 and Figure V.
 C) Carefully lift the playfield. Locate the switch assembly identified from the number. Visually inspect the switch assembly. If the contacts are 'stuck,' regap them to 1/16". See section under ADJUSTMENTS. Repeat A & B. If the game is correct, it is now ready to play.* If game is not correct, turn the power OFF.
 D) Replace MPU module A4. See CAUTION NOTE 1, C.
 E) Repeat A & B. If the game is correct, it is now ready to play.* If the game is not correct, refer to Module Replacement Procedure. (See Parts List).
- 7) **SYMPTOM:** Game blows fuse(s) repeatedly.
ACTION: See Module Replacement Procedure. F.O. 560

*Turn power On-Off switch OFF and then ON.

**GAME #1210 SKATEBALL (FIGURE V)
SOLENOID IDENTIFICATION TABLE**

Self Test #	SOLENOID IDENTIFICATION
01	OUTHOLE KICKER
02	KNOCKER
03	SAUCER
04	LEFT SLINGSHOT
05	RIGHT SLINGSHOT
06	LEFT THUMPER BUMPER
07	BOTTOM THUMPER BUMPER
08	RIGHT THUMPER BUMPER
09	5 DROP TARGET

Self Test #	SOLENOID IDENTIFICATION
10	3 DROP TARGET (TOP)
11	3 DROP TARGET (MIDDLE)
12	COIN LOCKOUT DOOR
13	KI RELAY (FLIPPER ENABLE)

SWITCH ASSEMBLY SELF-TEST DISPLAY NUMBERS

Switch Self Test #	DESCRIPTION
01	
02	MIDDLE RIGHT DROP TARGET
03	MIDDLE CENTER DROP TARGET
04	MIDDLE LEFT DROP TARGET
05	SAUCER
06	CREDIT BUTTON
07	TILT (3)
08	OUTHOLE
09	COIN III (RIGHT)
10	COIN I (LEFT)
11	COIN II (MIDDLE)
12	
13	#3 LANE
14	#2 LANE
15	# 1 LANE
16	SLAM (2)
17	3 DROP TARGET & 4 30 POINT REBOUNDS
18	"B" LANE
19	"A" LANE
20	E DROP TARGET

Switch Self Test #	DESCRIPTION
21	T DROP TARGET
22	A DROP TARGET
23	K DROP TARGET
24	S DROP TARGET
25	
26	TOP RIGHT DROP TARGET
27	TOP CENTER DROP TARGET
28	TOP LEFT DROP TARGET
29	
30	LOWER ROLLOVER BUTTON
31	UPPER ROLLOVER BUTTON
32	RIGHT FLIPPER BUTTON
33	SPINNER
34	RIGHT OUT SPECIAL
35	LEFT OUT SPECIAL
36	RIGHT SLINGSHOT
37	LEFT SLINGSHOT
38	RIGHT THUMPER BUMPER
39	BOTTOM THUMPER BUMPER
40	LEFT THUMPER BUMPER

**NOTE: SLINGSHOT & THUMPER BUMPER COILS
WILL BE ENERGIZED WHEN SWITCH IS MADE.**

#1210 SKATEBALL

○ INDICATES SWITCH ASSEMBLY IDENTIFICATION NUMBERS.

NOTE: CABINET: 07, 16, 32
DOOR: 06, 09
10, 11, 16

□ INDICATES SOLENOID IDENTIFICATION NUMBERS.

NOTE: DOOR: 12
BACKBOX: 13
CABINET: 02

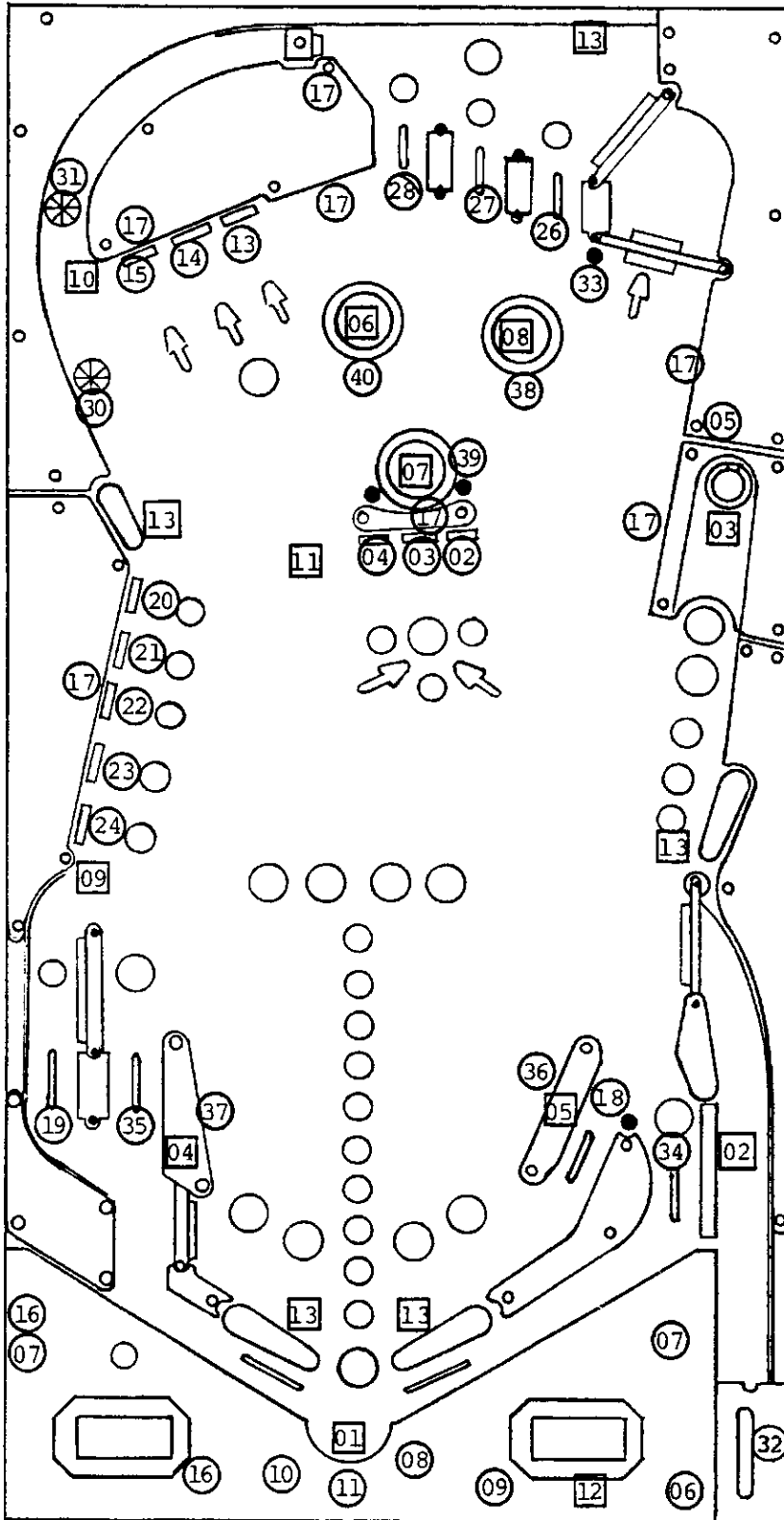

FIGURE V

ASSEMBLY ADJUSTMENTS:

GENERAL:

All switch assemblies consist of leaf springs, contacts, separators, plastic tubing and screws to hold them to the mounting surface. Before attempting to adjust a switch assembly, make sure that these screws are tight. If not, tighten screw closest to the contact end of the leaf spring first. This will prevent the assembly from being secured in such a manner that the leaf springs tend to fan out. In general, all leaf springs are adjusted for a 1/16" gap in the open position and .010" overtravel or wipe in the closed position. All contacts should be in good condition. Unless otherwise instructed, they should be dry or non-lubricated. All contacts should be free of dust and dirt. Contacts, with the exception of the flipper button switch assemblies, are plated to resist corrosion. Filing or burnishing breaks the finish and encourages corrosion. Clean by closing the contacts over a clean piece of paper (e.g. a business card) and wiping gently until the contacts are clean. For the flipper button switch assemblies **ONLY:** Tarnish can be removed with a contact file followed by a burnishing tool. Severely pitted contacts must be replaced as an assembly. In general, contacts need be cleaned or replaced and adjusted only when they are found to be a source of game malfunction.

X. SERVICE PARTS:

A parts catalogue is available upon request. The catalogue is illustrated and lists all replacement parts for each game manufactured by Bally. Requests should be addressed to:

BALLY MANUFACTURING CORPORATION
2640 WEST BELMONT AVENUE
CHICAGO, ILLINOIS 60618
ATTN: PARTS DEPARTMENT

SERVICE HINTS:

The Bally playfield has an improved tuff-coat finish with excellent wearing properties. Its life expectancy, as well as play appeal, can be extended by periodic cleaning of the playfield.

DO: Bally recommends you clean your playfield with Wildcat #125 (Wildcat Chemical Co., 1333 W. Seminary Drive, Ft. Worth, Texas 76115). Wildcat #125 is a combination cleaner and polish. Bally has tried and tested this product and found it to be very effective. If Wildcat #125 is not available, Bally suggests you ask your Distributor to order it. Inspect and hand polish the ball in a clean cloth. A chipped ball must be replaced. It can ruin the finish on the playfield in a short period of time.

DON'T: Use water in large quantities, highly caustic cleaners, abrasive cleaners or cleaning pads on the playfield. Do not allow a wax or polish build up. Waxes yellow with age and spoil play appeal.

**XI. PARTS LIST
#1210 SKATEBALL**

MISCELLANEOUS	PART NUMBER
Transformer (Domestic or Export)	E-122-125
Bulbs, #44	E-125-22
Fuse, 1 Amp. 3 AG Slow Blow (Playfield Solenoid Protection)	E-133-44

ASSEMBLY COILS	
Coin Lockout	FO-36-7000
Flipper (4)	AQ-25-500/ 34-4500
Knocker	AR-26-1200
Outhole Kicker	AN-26-1200
Thumper-Bumper (3)	AN-26-1200
Sling-Shot (2)	AO-26-1200
Drop Target (3)	NO-26-1900
Saucer	AO-27-1300
Up Kicker	NO-26-1900
Down Kicker	AO-26-1200

PLAYFIELD PARTS See Figure II

MODULES	
Lamp Driver A5	AS-2518-23
Display Driver A1 (1 Used)	AS-2518-21
Display Driver A1 (4 Used)	AS-2518-58
Solenoid Driver/Voltage Regulator A3	AS-2518-22
MPU A4	AS-2962-22
Transformer & Rectifier A2	AS-2877-1
Rectifier Board (Part of A2)	AS-2518-18
Sound	AS-3022-11

REPAIRS PROCEDURES/AIDS	
Module & Component Replacement	F.O.560-1
AID (Assistance in Diagnostics)	
Kit, used with F.O.560-1	KIT #485-1

MODULE COMPONENTS
SEE MODULE PARTS LIST

MODULE COMPONENT STARTER KITS
(Each Kit contains an assortment of the most needed electronic parts for use in Module repair.)
Kit #490—For Rectifier Board (Part of A2)
Kit #503—For MPU Board A4 (Less Memory U1-U6)
Kit #492—For Solenoid Driver/Voltage Regulator A3
Kit #493—For Display Driver A1
Kit #494—For Lamp Driver A5
Kit #559—For Sound A8

AS-2518-35 MPU MODULE

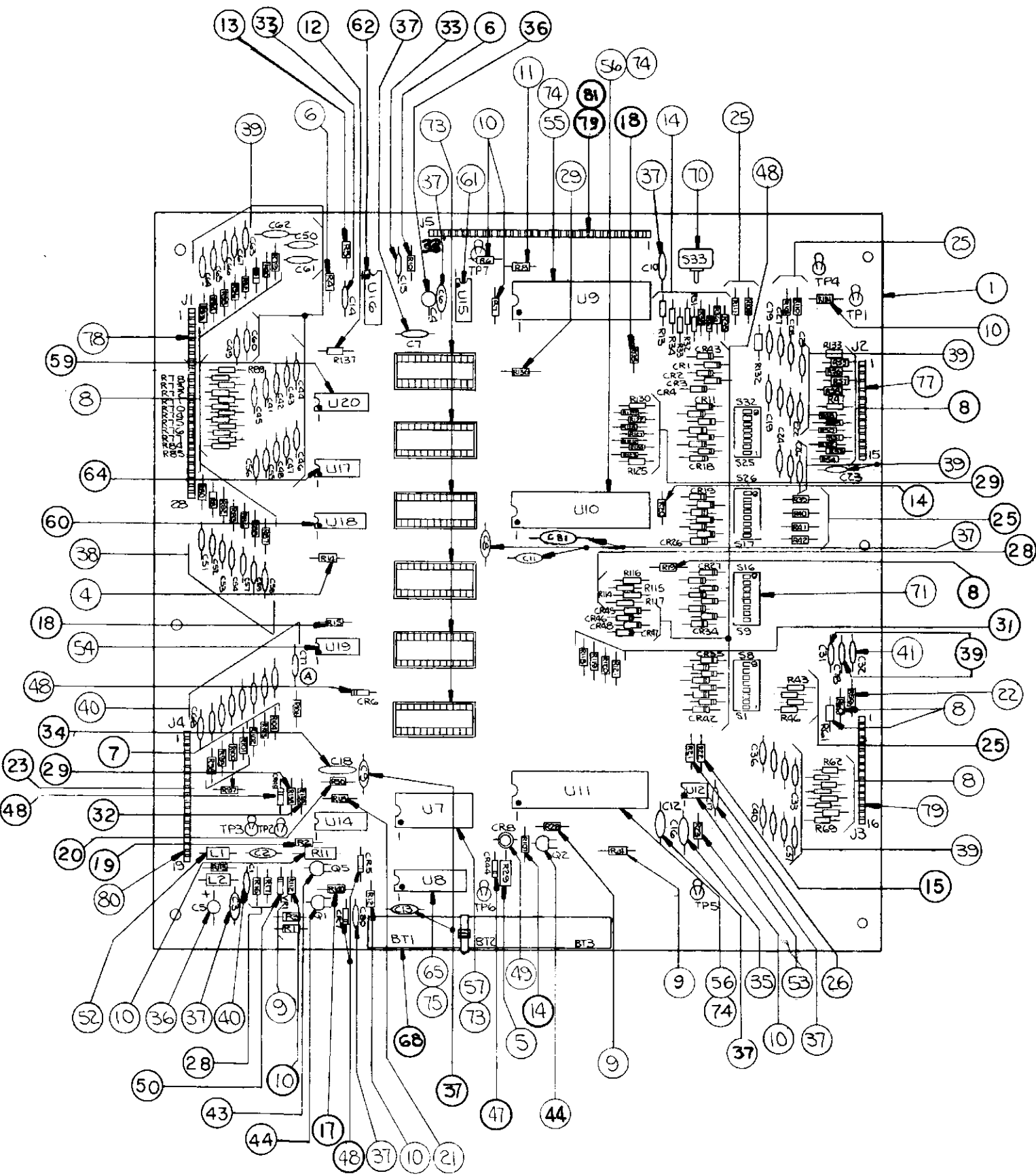

A4: MPU MODULE COMPONENT PARTS LIST

ITEM	REFERENCE DESIGNATION	BALLY PART #	DESCRIPTION
1	A4 (see note 1)	AS-2962-22	MPU Module Complete. Skateball
2	A4 (see note 2)	AS-2518-35	MPU Module less Program Memory, U1-6 incl.
3-32	See Schematic		Resistors, See schematic for value
33	C14, C15	E-00586-0067	Capacitor, 470 PFD, 1kv
34	C18	E-00586-0088	Capacitor, .05 MFD, 16V
35	C16	E-00586-0081	Capacitor, .1 MFD, 100V
36	C4, C5	E-00586-0073	Capacitor, 4.5 MFD, 25V
37	C3, C6-C13, C17, C81	E-00586-0085	Capacitor, .01 MFD, 25V
38	C79, C41-C67	E-00586-0083	Capacitor, 470 PFD, 50V
39	C19-C31, C78, C33-C40	E-00586-0082	Capacitor, 390 PFD, 50V
40	C1, C2, C68-C77	E-00586-0084	Capacitor, 820 PFD, 50V
41	C32	E-00586-0077	Capacitor, 3000 PF, 1kv
43	Q5	E-00585-0023	Transistor PNP (MPS-3702)
44	Q1, Q2	E-00585-0031	Transistor (2N3904)
47	CR44	E-00587-0006	Diode (IN4004)
48	CR1-CR7, CR11-CR43, CR45-CR49	E-00587-0014	Diode (IN4148)
49	CR8	E-00679	LED (Green)
50	VR1	E-00598-0008	Diode Zener (8.2V, IN9598)
52	L1, L2	E-00604-0003	Inductor, 22 Micro Hy.
53	U12	E-00620-0004	Timer (555)
54	U19	E-00620-0005	Quad 2 Input (4011)
55	U9	E-00620-0028	MPU I.C. (6800)
56	U10, U11	E-00620-0029	PIA I.C. (6820)
57	U7	E-00620-0030	RAM I.C. (6810)
59	U20	E-00620-0032	HEX Buffer I.C. (14502B)
60	U14, U18	E-00620-0033	HEX Inverter (4049B)
61	U15	E-00620-0034	Quad Memory Drive (MC3459L)
62	U16	E-00620-0035	Dual Monostable (9602)
64	U17	E-00620-0041	Quad 2 Inputs (74L00N)
65	U8	E-00620-0042	RAM (C MOS, P5101L-3)
68	BT1, BT2, BT3	E-00628-0003	Battery
70	S33	E-00658-0001	Push Button Switch
71	S1-S8, S9-S16, S17-S24, S25-S32	E-00677	DIP Switch
73		E-00712	24 Pin Socket
74		E-00712-0001	40 Pin Socket
75		E-00712-0003	22 Pin Socket
77	J2	E-00715	15 Pin Wafer Connector
78	J1	E-00715-0004	28 Pin Wafer Connector
79	J3, J5	E-00715-0017	16 Pin Wafer Connector
80	J4	E-00715-0018	19 Pin Wafer Connector
81	J5	E-00715-0024	17 Pin Wafer Connector

NOTE 1:

When ordering, fill in dash number. For example, AS-2962-0: LOST WORLD, AS-2962-2: SIX MILLION DOLLAR MAN, AS-2962-3: PLAYBOY, AS-2962-4: VOLTAN, AS-2962-5: SUPERSONIC, AS-2962-6: STAR TREK, AS-2962-7: KISS, AS-2962-8: PARAGON, AS-2962-9: GROUND SHAKER, AS-2962-10: HARLEM GLOBE-TERS, AS-2962-12: DOLLY PARTON, AS-2962-13: SILVERBALL MANIA, AS-2962-18: MYSTIC, AS-2962-20: HOTDOGGIN, AS-2962-22: SKATEBALL

NOTE 2: Order replacement memory chips U1-U6, specifying game, socket and part number stamped on chip.

AS-2518-23 LAMP DRIVER MODULE

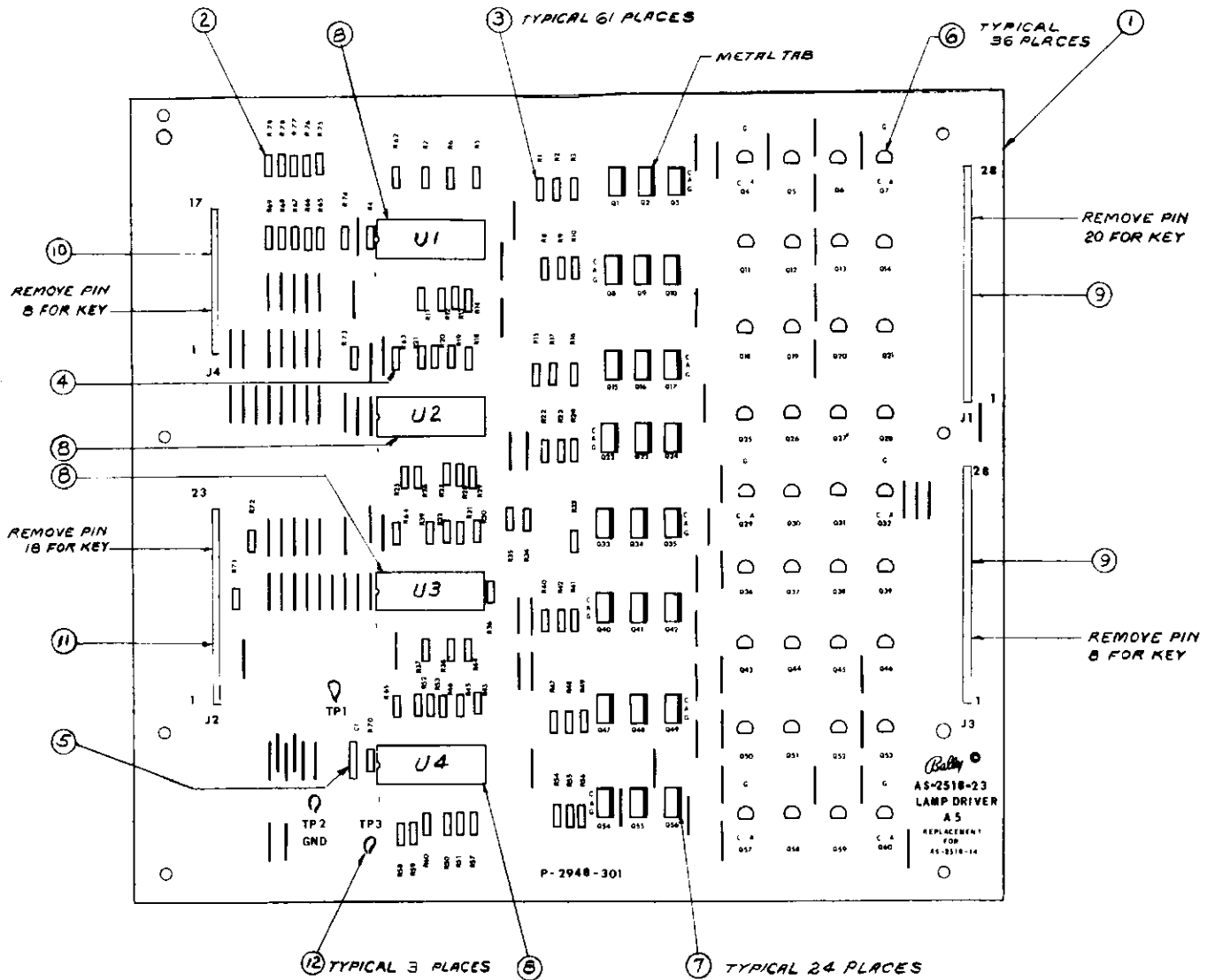

A5: LAMP DRIVER MODULE COMPONENT PARTS LIST

ITEM	REFERENCE DESIGNATION	BALLY PART #	DESCRIPTION
1	A5	AS-2518-23	Lamp Driver Module, Complete
2	R71-R79	E-00105-242	Resistor, 20k Ω , 5%, 1/4 W
3	R1-R60, R70	E-00105-0237	Resistor, 2k Ω , 5%, 1/4 W
4	R61-R69	E-00105-0256	Resistor, 2.2M Ω , 1/4 W
5	C1	E-00586-0065	Capacitor, .01 MFD, 500V
6	Q4-Q7, Q11-Q14, Q18-Q21, Q25-Q32, Q36-Q39, Q43-Q46, Q50-Q53, Q57-Q60	E-00585-0014	SCR, 2N5060
7	Q1-Q3, Q8-Q10, Q15-Q17, Q22-Q24, Q33-Q35, Q40-Q42, Q47-Q49, Q54-Q56	E-00585-0029	SCR, MCR106-1
8	U1-U4	E-00620-0037	I.C., Decoder, 14514B
9	J1, J3	E-00715-0004	28 Pin Wafer Connector
10	J4	E-00715-0024	17 Pin Wafer Connector
11	J2	E-00715-0014	23 Pin Wafer Connector
12	TP1, TP2, TP3	P-05399	Test Clip

AS-2518-21 CREDIT DISPLAY DRIVER MODULE

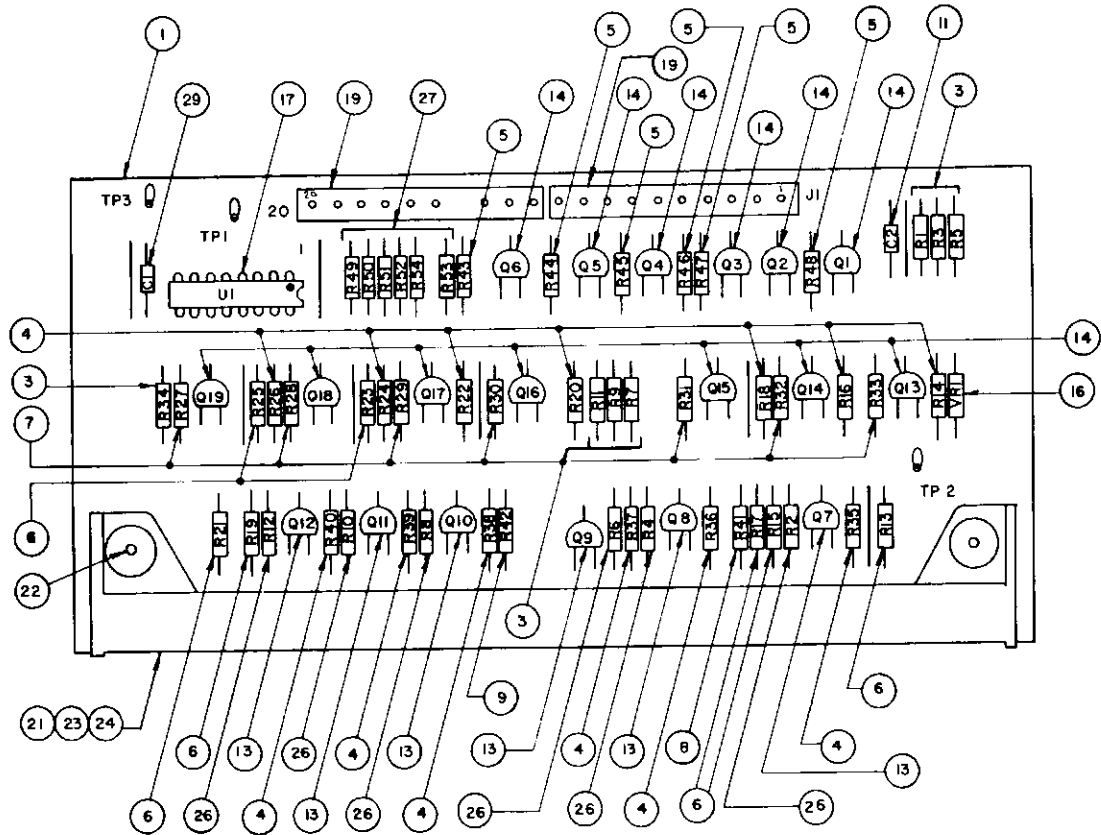

A1: 6 DIGIT DISPLAY DRIVER MODULE COMPONENT PARTS LIST

ITEM	QTY.	REFERENCE DESIGNATION	BALLY PART #	DESCRIPTION
1	1		P-2948-296	P.C. Board, M-645-392
3	7	R1, R3, R5, R7, R9, R11, R34	E-105-331	Resistor, 100K Ω
4	13	R14, R16, R18, R20, R22, R24, R26, R35, R36, R37, R38, R39, R40	E-105-227	Resistor, 300K Ω
5	6	R43, R44, R45, R46, R47, R48	E-105-228	Resistor, 9.1K Ω
6	7	R13, R15, R17, R19, R21, R23, R25	E-105-229	Resistor, 1.5K Ω
7	7	R27, R28, R29, R30, R31, R32, R33	E-105-222	Resistor, 1.2K Ω
8	1	R41	E-105-231	Resistor, 39K Ω
9	1	R42	E-105-271	Resistor, 240K Ω
10				
11	1	C2	E-586-65	Capacitor, .01 MFD, 500V
13	6	Q7, Q8, Q9, Q10, Q11, Q12	E-585-32	Transistor (2N5401)
14	13	Q1, Q2, Q3, Q4, Q5, Q6, Q13, Q14, Q15, Q16, Q17, Q18, Q19	E-585-33	Transistor (MPS-A42)
16	1	VR1	E-598-7	Zener Diode, 110V
17	1	U1	E-620-38	I.C. Decoder
18				
19	2	J1	E-715-34	10 Pin Wafer Pin Connector
21	1	DS1	E-680	Digital Display Panel
22	2		M-1836	Hi-Lo Screw, W/H
23	1		P-2399	Display Mounting (Top)
24	1		P-2399-1	Display Mounting (Bottom)
26	6	R2, R4, R6, R8, R10, R12	E-105-287	Resistor, 2.2K Ω
27	6	R49, R50, R51, R52, R53, R54	E-105-242	Resistor, 20K Ω
28	As Req'd			Wire Jumper
29	1	C1	E-586-85	Capacitor, .01 MFD, 25V

NOTE: INTERCHANGEABLE WITH AS-2518-15

AS-2518-22 SOLENOID DRIVER/VOLTAGE REGULATOR MODULE

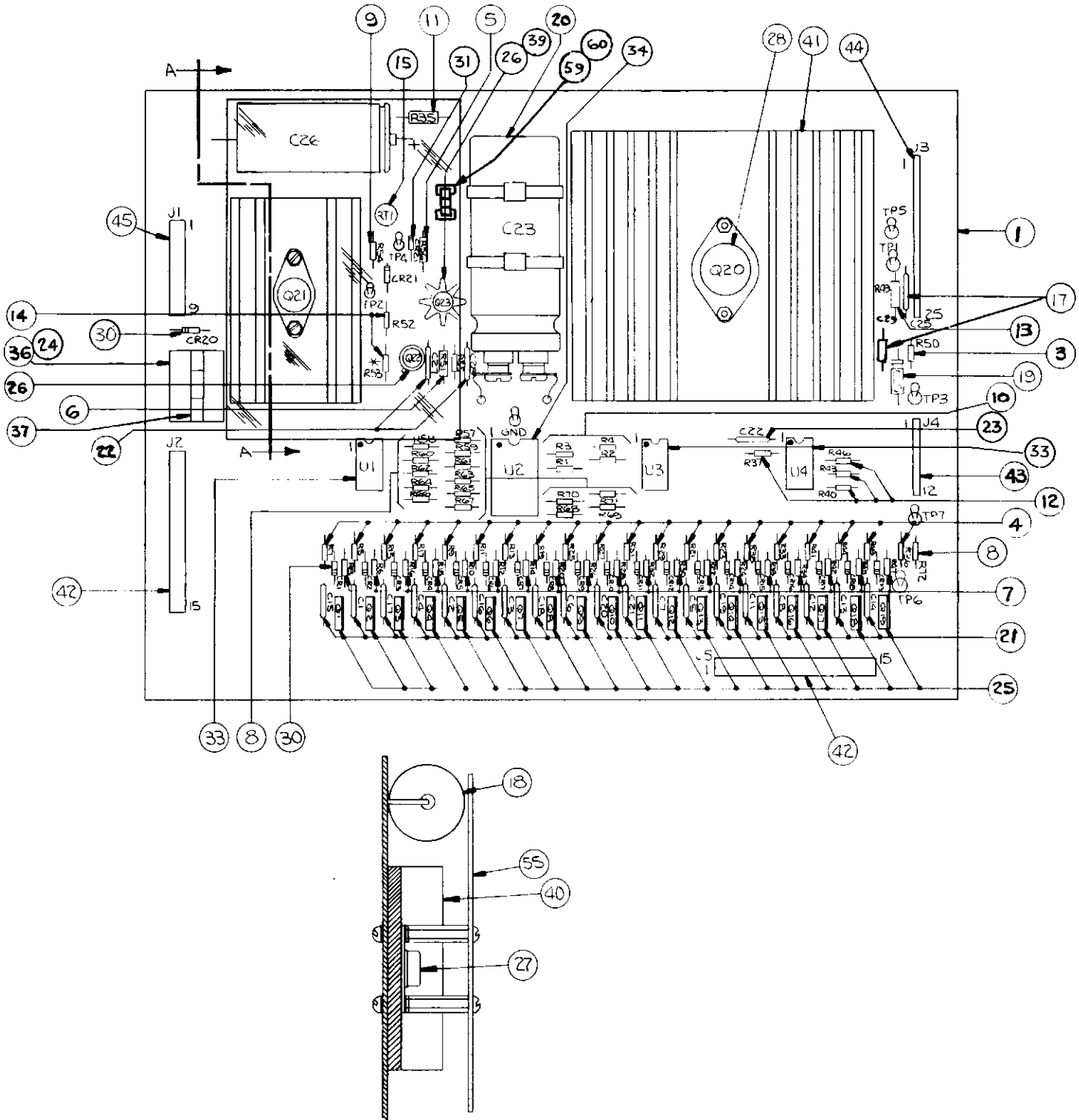

NOTE: INTERCHANGEABLE WITH AS-2518-16

A3: SOLENOID DRIVER/VOLTAGE REGULATOR MODULE

COMPONENT PARTS LIST

ITEM	REFERENCE DESIGNATION	BALLY PART #	DESCRIPTION
1	A3	AS-2518-22	Solenoid Driver/Voltage Regulator Module, Complete
3-14	Resistors		Resistor, See Schematic for value.
15	RT1	E-00599-0014	Pot. (Linear) 25K
17	C25, 29	E-00586-0014	Capacitor, .1 MFD, 20V
18	C26	E-00586-0059	Capacitor, 160 MFD, 350V
19	C24	E-00586-0063	Capacitor, 2 MFD @ 25V
20	C23	E-00586-0062	Capacitor, 11700 MFD, 20V
21	C1-C8, C11-C21	E-00586-0064	Capacitor, .002 MFD, 1kv
22	C27, C28	E-00586-0065	Capacitor, .01 MFD, 500V
24	K1	E-00146-0795	Relay, Printed Circuit
25	Q1-Q19	E-00585-0034	Transistor, SE9302
26	Q22, Q23	E-00585-0041	Transistor, 2N3440
27	Q21	E-00585-0042	Transistor, 2N3584
28	Q20	E-00710	+5V Regulator, LAS1405 or 78H05KC or LM323K
30	CR1-CR21	E-00587-0015	Diode (IN4004)
31	VR1	E-00598-0010	Diode, Zener 140V, IN5275A
33	U1, U3, U4	E-00681	I.C. Transistor Array, CA3081
34	U2	E-00620-0039	I.C. Binary to 1/16 Decoder, 74L154
36		E-00592-0002*	Relay Socket
37		M-1839*	Relay Holder
39		E-00682	Heat Sink, TO5
40		E-00682-0001	Heat Sink, TO66
41		E-00682-0002	Heat Sink, TO3 Case
42		E-00715-0039	15 Pin Wafer Connector
43		E-00715-0016	12 Pin Wafer Connector
44		E-00715-0020	25 Pin Wafer Connector
45		E-00715-0033	9 Pin Wafer Connector
55		M-1838	Shield-Plexiglass
59		E-00148-0021	Fuse Clips
60	F1	E-00133-0029	Fuse 8 AG-3/16 Amp.
23	C22	E-00586-0085	Capacitor, .01 MFD, 25V

*USED WITH ITEM 24, E-00146-0791, PLUG IN RELAY ONLY

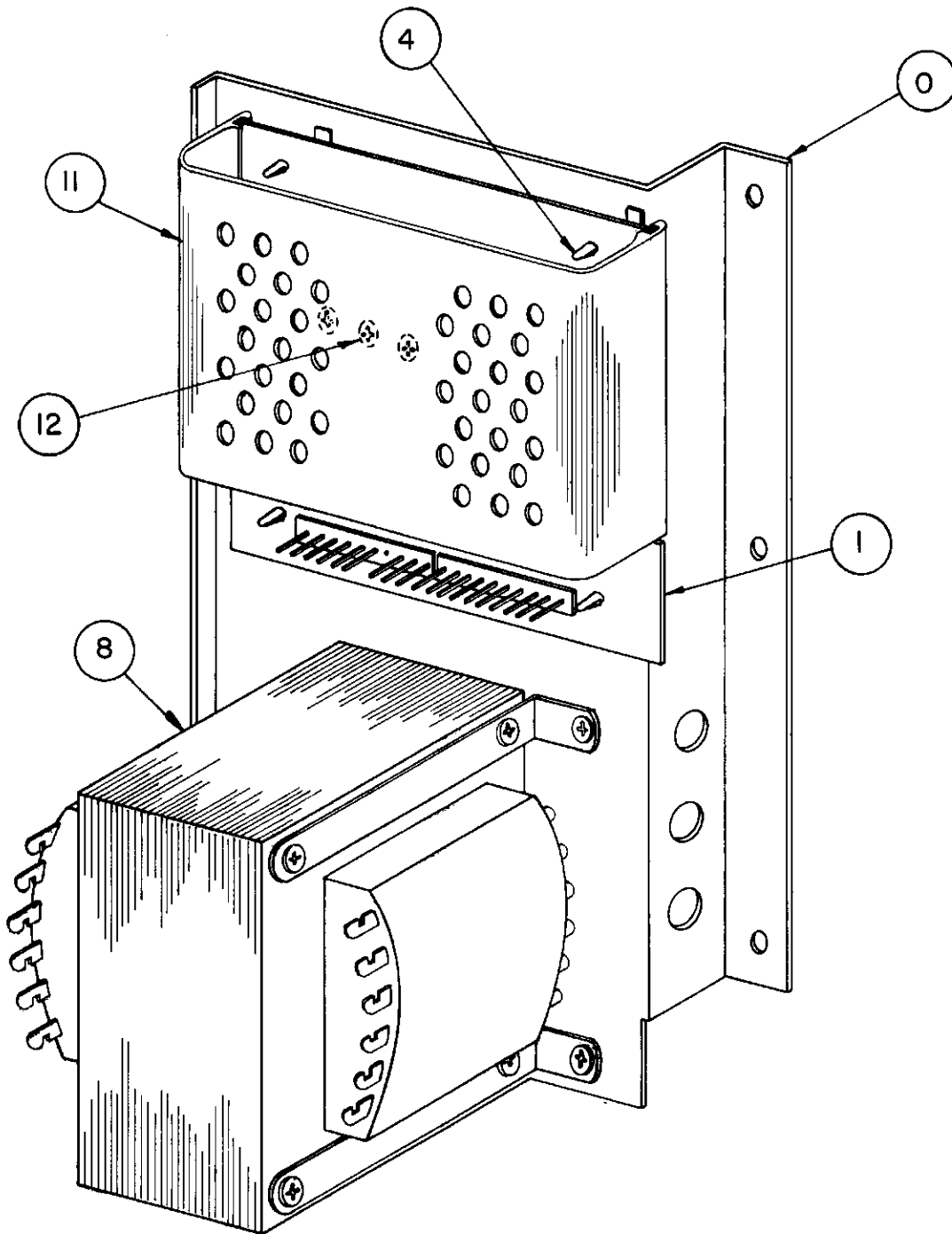

**A2: POWER TRANSFORMER MODULE
COMPONENT PARTS LIST**

ITEM	REFERENCE DESIGNATION	BALLY PART #	DESCRIPTION
0	A2	AS-2877-1	Power Transformer Module, Complete
1		AS-2518-18	Rectifier Board Assembly
4		M-1829-2a	Circuit Board Support (4 Req'd.)
8		E-00122-0125c	Transformer 120/240V, 50/60 Hz
11		P-2692b	P.C.B Cover
12		M-1834	Heat Sink Compound

AS-2518-18 RECTIFIER BOARD ASSEMBLY

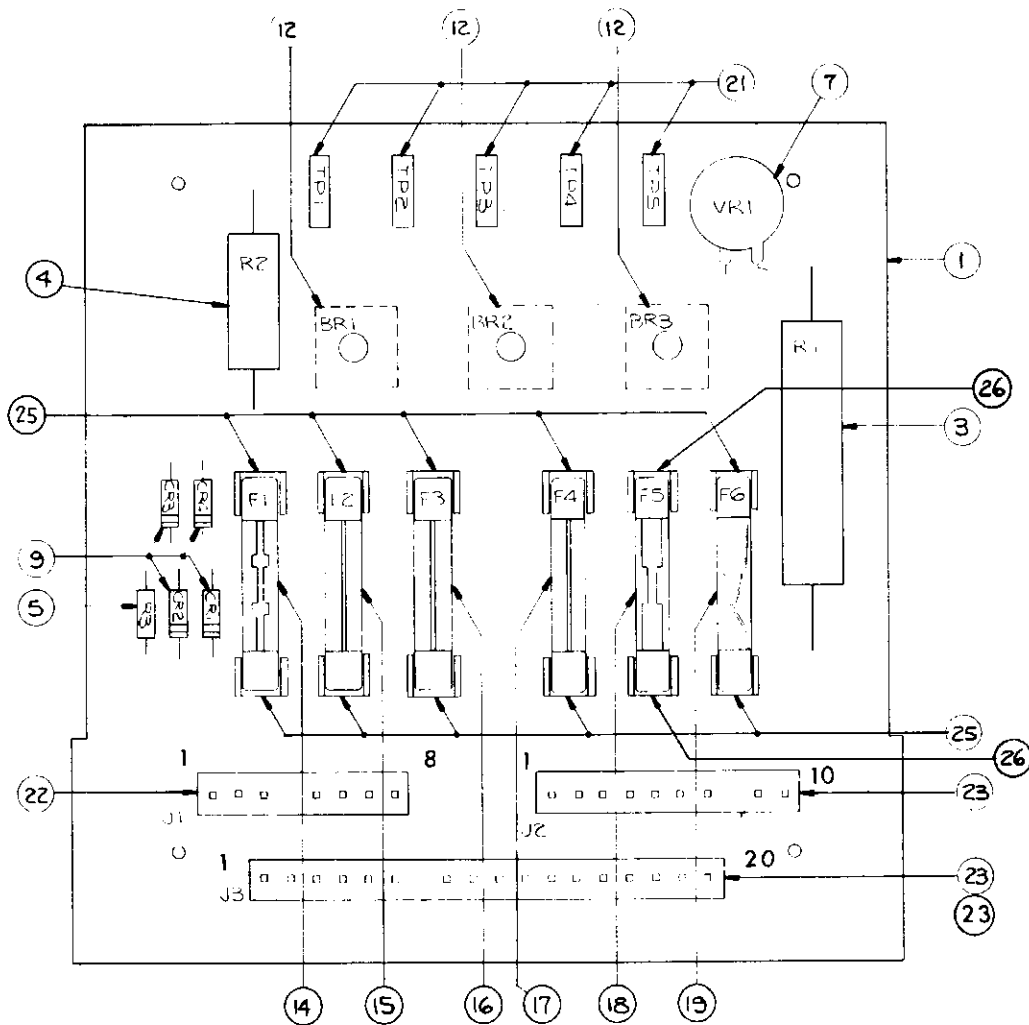

RECTIFIER BOARD ASSEMBLY (Part of) A2: POWER TRANSFORMER MODULE COMPONENT PARTS LIST

ITEM	REFERENCE DESIGNATION	BALLY PART #	DESCRIPTION
1	P/O A2	AS-2518-18	Rectifier Board Assembly, Complete
3	R1	E-00104-0092	Resistor, 10%, 600 Ohm, 10W
4	R2	E-00104-0091	Resistor, 25 Ohm, 5W
5	R3	E-00105-0226	Resistor, 5%, 100K Ohm, 1/4W
7	VR1	E-00623	Varistor
9	CR1, CR2, CR3, CR4	E-00587-0006	Diode (IN4004)
12	BR1, BR2, BR3	E-00602-0003	Bridge Rectifier (VJ248 VARO)
14	F1	E-00133-0010	Fuse, 10A, 32V, 3AG
15	F2	E-00133-0028	Fuse, 3/4A, 250V, 3AG,
16	F3	E-00133-0004	Fuse, 4A, 32V, 3AG
17	F4	E-00133-0005	Fuse, 5A, 32V, 3AG
18	F5	E-00133-0027	Fuse, 20A, 32V, 3AG
19	F6	E-00133-0024	Fuse, 3A, 3AG, S.B.
21		E-00684	Test Point
22	J1,	E-00715-0032	8 Pin Wafer Connector
23	J2, J3	E-00715-0034	10 Pin Wafer Connector
25		E-00148-0021	Fuse Clips
26		E-00148-0022	Fuse Clips

A8: SOUND MODULE COMPONENT PARTS LIST

ITEM	REFERENCE DESIGNATION	BALLY PART NO.	DESCRIPTION
1	A8 (see note 1)	AS-3022-9	PWB Module Complete
2	U1	E-620-124	Sound Chip AY-3-8910
3	U2	E-620-29	PIA, 6820/21
4	U3	E-620-125 (E620-128)	CPU, 6808 (6802 Note 3)
5	U10	E-620-30	Ram, 6810 (Note 3)
6	U5	E-620-33	Hex Inverter 4049B
7	U6	E-620-5	Quad 2 Input 4011B
8	U8	E-620-126	Amp, LM3900
9	U9	E-620-127	Power Amp, TDA 2002
10	Q1	E-585-31	Transistor, 2N3904
11	CR1, 2	E-587-6	Diode, 1N4004
12	SW1	E-658-1	Switch
13	C12	E-586-118	Cap. .2MF ±20% Y5P, 16 V.
14	C2	E-586-130	Cap. .47 ±20%
15	C16	E-586-83	Cap. 470 PF 50 V.
16	C3	E-586-120	Cap. 68 PF, ±20% 1K
17	C18, 19	E-586-121	Cap. 27 PF, ±20% 1K
18	Y1	E-744-5	Crystal, 3.579545 MHZ
19	J2	E-736-2	Connector, Wafer, 2 Pin KK156
20	J1	E-736-15	Connector, Wafer, 15 Pin KK156
21	R9	E-105-196	Resistor, 1 Ohm, ¼ W., 5%
22	R8	E-105-211	Resistor, 2.2 Ohm, ¼ W., 5%
23	R7	E-105-303	Resistor, 220 Ohm, ¼ W., 5%
24	R1	E-105-230	Resistor, 1 K, ¼ W., 5%
25	R21, 22, 23, 24	E-105-238	Resistor, 3.3K. Ohm, ¼ W., 5%
26	R6	E-105-239	Resistor, 4.7K., ¼ W., 5%
27	R3, 14, 15, 16, 17, 18, 19, 25	E-105-185	Resistor, 10K., ¼ W., 5%
28	R2	E-105-245	Resistor, 30K., ¼ W., 5%
29	R10	E-105-252	Resistor, 180K., ¼ W., 5%
30	R4	E-105-225	Resistor, 200K., ¼ W., 5%
31	R5, 20	E-105-285	Resistor, 1M, ¼ W., 5%
32	RT1	E-599-16	Potentiometer 1K
33	C23	E-586-122	Cap. .001 ±20% 2SF
34	C15	E-586-123	Cap. 4700 MF @ 25 V.
35	C7	E-586-124	Cap. 470 MF @ 6.3 V
36	C8	E-586-129	Cap. 470 MF @ 16 V.
37	C5, 13	E-586-90	Cap. 1 MF @ 50 V.
38	C9, 1, 14, 6	E-586-89	Cap. .1 MF
39	C4, 22, 17, 21, 20, 24	E-586-85	Cap. .01 MF
40	XU10, XU4	E-712	Socket, 24 Pin
41	XU1, XU2, XU3	E-712-1	Socket, 40 Pin
42	Used with 43	LSPR-00632-1106	Bolt, 6 x 32 x ¾
43	Used with 42	N-00632-2112	Nut, 6 x 32
44	H.S for U9	E-682-8	Heat Sink, 6030BTT
45	Used with C15	E-647-5	Ty Rap
46	TP1, 2, 3, 4, 5, 6	P-5399	Test Point
47	Use with 44, 9	M-1834	Thermal Grease
48	Jumper, B	W-1211c	22 AWG Wire, Solid Tinned Schematic

NOTE 1: When ordering specify name of game.

NOTE 2: Order replacement memory chip U4 specifying name of game and part no. stamped on chip.

NOTE 3: When using item 4, 6808 you must use item 5, 6810 and the "B" jumper. When item, 6802 is available delete item 5 and use "A" jumper.

AS-2518-51 SOUND MODULE

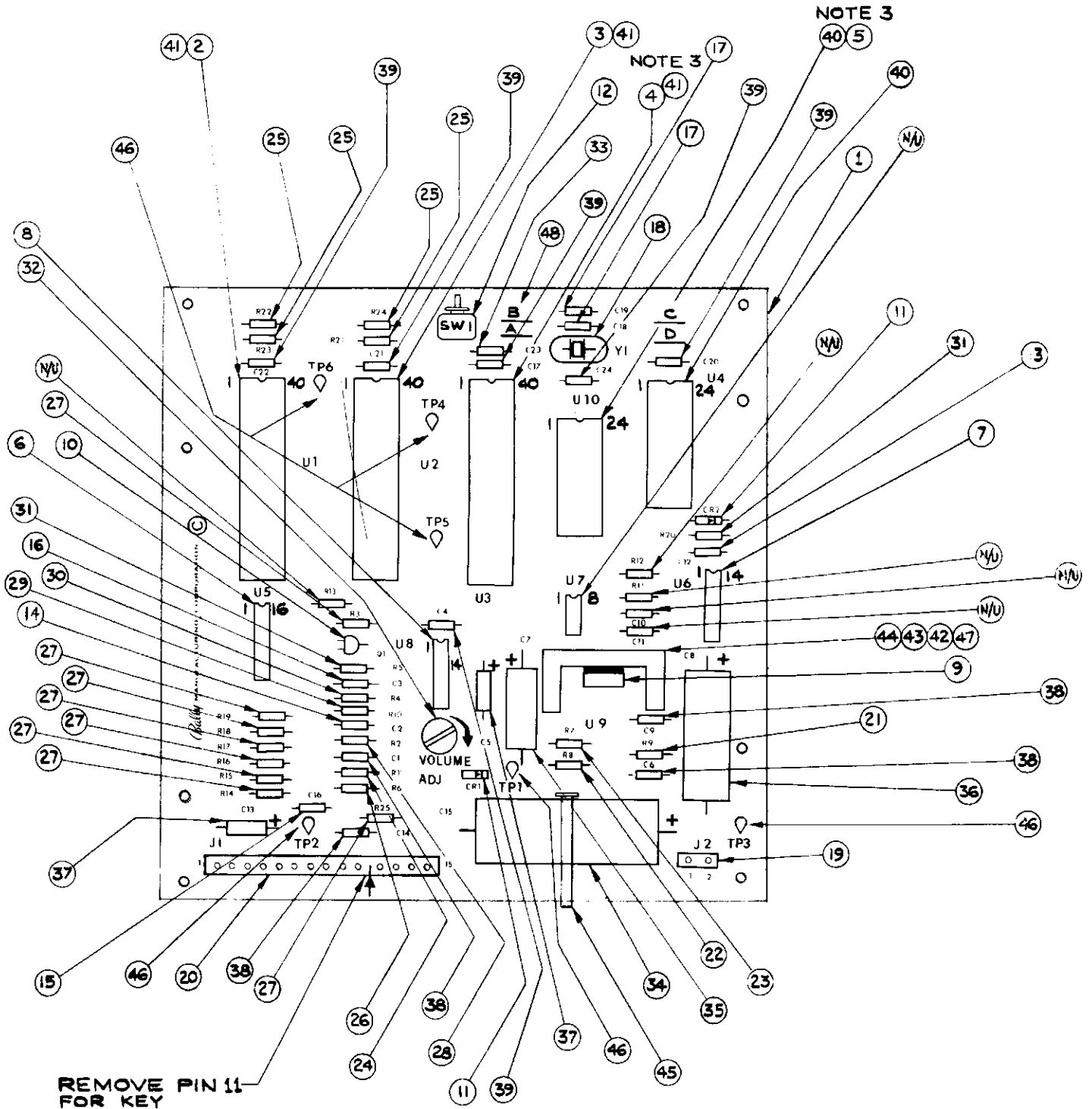

AS-2518-58 DISPLAY DRIVER MODULE

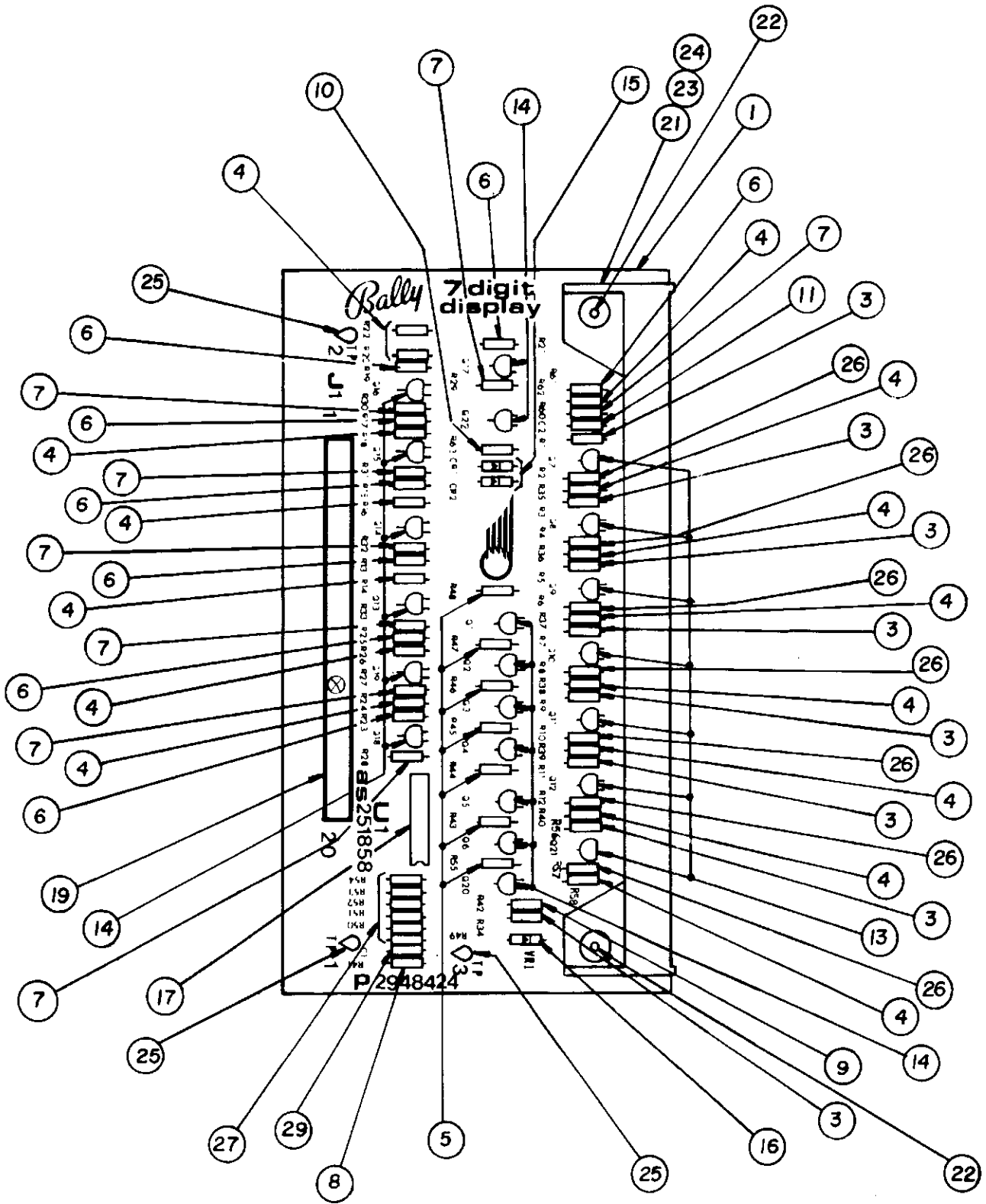

A1: 7 DIGIT DISPLAY DRIVER MODULE

COMPONENTS PARTS LIST

ITEM	QTY.	REFERENCE DESIGNATION	BALLY PART #	DESCRIPTION
1	1		P-2948-424	P.C. Board, M-645 546
3	8	R1, R3, R5, R7, R9, R11, R34, R56	E-105-331	Resistor, 100K Ω
4	15	R14, R16, R18, R20, R22, R24, R26, R35, R36, R37, R38, R39, R40, R58, R56	E-105-227	Resistor, 300K Ω
5	7	R43, R44, R45, R46, R47, R48, R55	E-105-228	Resistor, 9.1K Ω
6	8	R13, R15, R17, R19, R21, R23, R25, R61	E-105-229	Resistor, 1.5K Ω
7	8	R27, R28, R29, R30, R31, R32, R33, R60	E-105-222	Resistor, 1.2K Ω
8	1	R41	E-105-231	Resistor, 39K Ω
9	1	R42	E-105-271	Resistor, 240K Ω
10	1	R63	E-105-248	Resistor, 150K Ω
11	1	C2	E-586-65	Capacitor, .01 MFD, 500V
13	7	Q7, Q8, Q9, Q10, Q11, Q12, Q21	E-585-32	Transistor (2N5401)
14	15	Q1, Q2, Q3, Q4, Q5, Q6, Q13, Q14, Q15, Q16, Q17, Q18, Q19, Q20, Q22	E-585-33	Transistor (MPS-A42)
15	2	CR1-2	E-587-14	Diode (IN4148)
16	1	VR1	E-598-7	Zener Diode, 110V (IN3045A)
17	1	U1	E-620-38	I.C. Decoder (MC14543)
18				
19	2	J1	E-736-10	10 Pin Wafer Pin Connector (KK-156)
21	1	DS1	E-680-7	7 Digital Display Panel
22	2		M-1836	Hi-Lo Screw, W/H
23	1		P-2399	Display Mounting (Top)
24	1		P-2399-1	Display Mounting (Bottom)
25	3	TP1-3	P-5399	Test Clip
26	7	R2, R4, R6, R8, R10, R12, R57	E-105-287	Resistor, 2.2K Ω
27	6	R49, R50, R51, R52, R53, R54	E-105-242	Resistor, 20K Ω
28				
29	1	C1	E-586-85	Capacitor, .01 MFD, 25V

VECTOR DRAWING FOR SKATEBALL
EJECT SAUCER

Top right flipper should be able to hit ball as indicated by vector or hit post as shown.

