

Custom Swappable Flipper Bats

A new way to easy swap out bats with the advantage of swapping between sizes without lifting the playfield in a matter of minutes.



Note: these bats are not the final version as are side mounted not top mounted like the revision. The side mounted design looks cleaner but is a bit more of a pain to install - photo to be updated soon.

Thank you for your support and I hope you will enjoy this mod for many years to come.

Proudly Designed and Manufactured by



There are currently 5 different types of flipper bat sets available requiring various parts. Refer to the below chart detailing the parts required.

Flipper Set 1 - 2 7/8" Long Flipper Bats

Flipper Set 2 - 3" Long Flipper Bats

Flipper Set 3 - 3" Long Flipper Ghostbusters PKE Meter Bats

Flipper Set 4 - 3 1/8" Long Flipper Bats

Flipper Set 5 - 3 1/8" Long Flipper Ghostbusters PKE Meter Bats

Each bat has a part number along with a quantity. Items 1-12 are purchased via Shapeways. Search "**SwinksCSF**" or the parts. *CSF = Custom Swappable Flippers*. Items 9-11 are either purchased via a bolt / hardware supplier or via Swinks.

Hardware Required

Custom Swappable Flippers

		Flipper Set 1	Flipper Set 2	Flipper Set 3	Flipper Set 4	Flipper Set 5
	Size	2 7/8"	3"	3"	3 1/8"	3 1/8"
	Type	Standard	Standard	Ghostbusters PKE	Standard	Ghostbusters PKE
Item No	Mount Type	Top Mount	Top Mount	Top Mount	Top Mount	Top Mount
1	CSF#1-Post	x 2	x 2	x 2	x 2	x 2
2	CSF#2-Bat	x 2				
3	CSF#3-Bat		x 2			
4	CSF#4-Bat			x 2		
5	CSF#5-Bat				x 2	
6	CSF#6-Bat					x 2
7	CSF#7-Fake Bulbs			x 2		x 2
8	CSF#8-Button GB Set			x 1		x 1
	Below - you can order locally or get them off Swinks for at cost fee.					
9	M4x10 SS Button Screws (Bat to Post)	x 2	x 2	x 2	x 2	x 2
10	M3x10 SS Button Screws (Fake Bulb to Bat - optional)			x 4		x 4
11	M4 Tap (required if you don't have one)	x 1	x 1	x 1	x 1	x 1
12	M3 Tap (required if you don't have one)			x 1		x 1
13	M2.5 Allen Key	x 1	x 1	x 1	x 1	x 1
	Note	Parts #2 to #8 - you will have a choice of 8 colours - White, Purple, Red, Pink, Blue, Yellow, Green, Orange - or purchase a white set and custom paint them.				

To order parts 1-8 head to [shapeways.com](http://www.shapeways.com) using the search of “swinksflippers”

<http://www.shapeways.com/search?q=swinksflipper&sort=name>

For the remaining parts 9-13 see below.

Regular Bats

2 off M4 x 10mm SS Button Allen Headed Bolts

1 off 2.5M Allen key

\$1 AUD for all 3 parts

or

GB PKE Bats

2 off M4 x 10mm SS Button Allen Headed Bolts

1 off 2.5M Allen key

4 off M3 x 10mm SS Cap Allen Headed Bolts

\$2 AUD for all 3 parts

plus if desired

Taps

1 off M4 - **\$8.50 AUD**

1 off M3 - **\$8.50 AUD**

These could be purchased much cheaper direct from China on eBay for about \$7 for both including free postage. These taps will last for many taps so only one needed for many sets of bats.

Postage

Postage & Padded envelope for all the above (and for less components) - **\$5 AUD**

Part Preparation

CSF#1 - Post are a universal part and has 2 holes in the top which needs to be tapped M4 x 0.7mm. These holes can be hand tapped with 4mm tap and a little bit of wax, oil or other lubricant. For the Flipper Sets 1-5 only need the top hole tapped as the other horizontal hole is for a possible future concept.

When tapping - apply some lubricant to the tap, fine oil or a wax (preferably cutting), centre the tap and rotate 3/4 of a turn then back 1/4 of a turn and then again 3/4 turn in and back 1/4 - continue until approximately 15mm deep. Take it easy and keep the tap straight and preferably use a tap handle but can be done with a spanner / shifter.

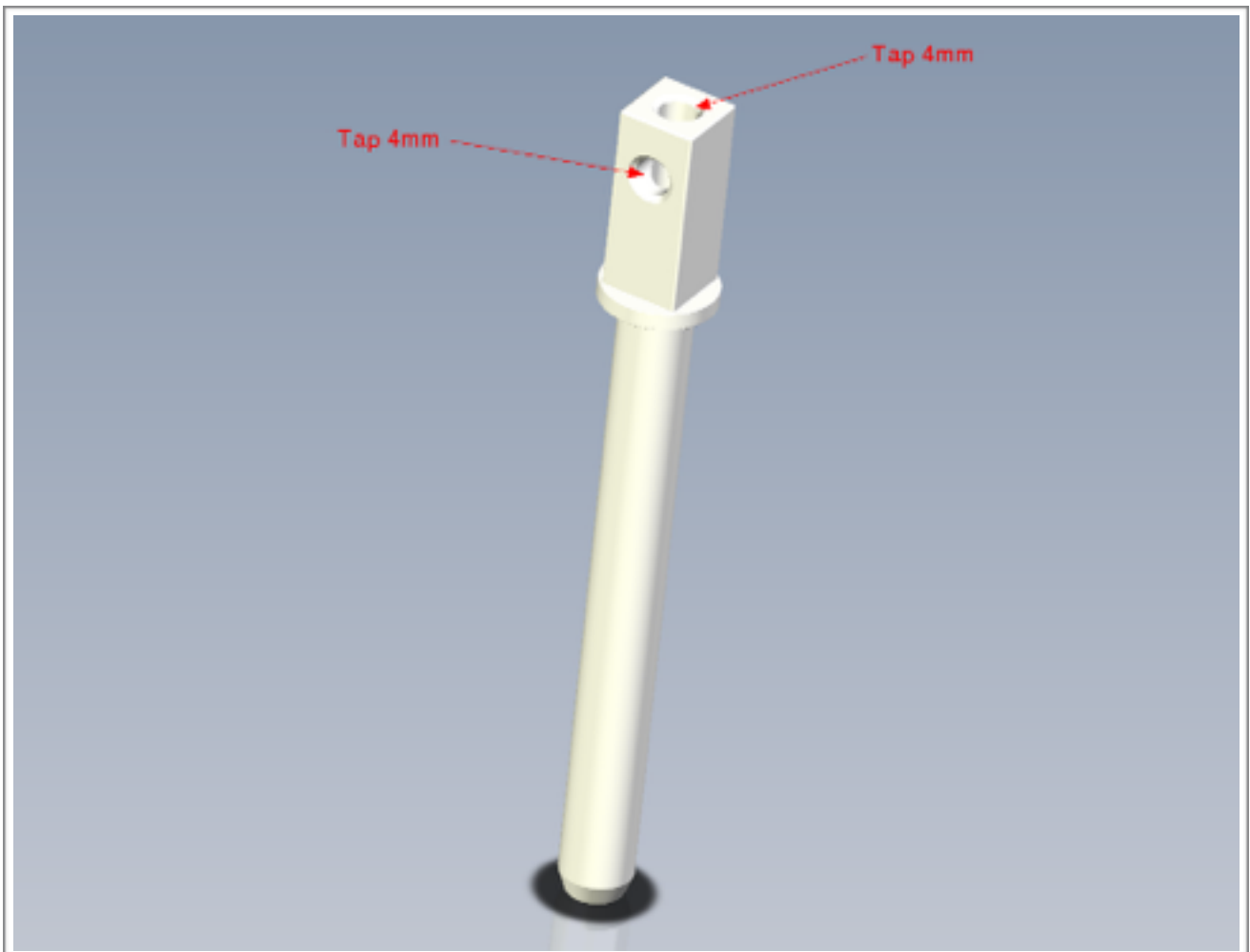

CSF#2-6 - Bats vary in length as well as top holes for the fake bulbs. When these are purchased straight from Shapeways they are tumbled (they state polished) but not a shiny polished finish so if you want a gloss finish you could add a clear coat or get a white set and paint up a custom colour. Otherwise they are ready to use. Below are just some sample options in various colours.

Red - 2 7/8" bats

Purple - 3" bats

White - 3" GB PKE bats

Yellow - 3 1/8" bats

Dark Grey - 3 1/8" GB PKE bats

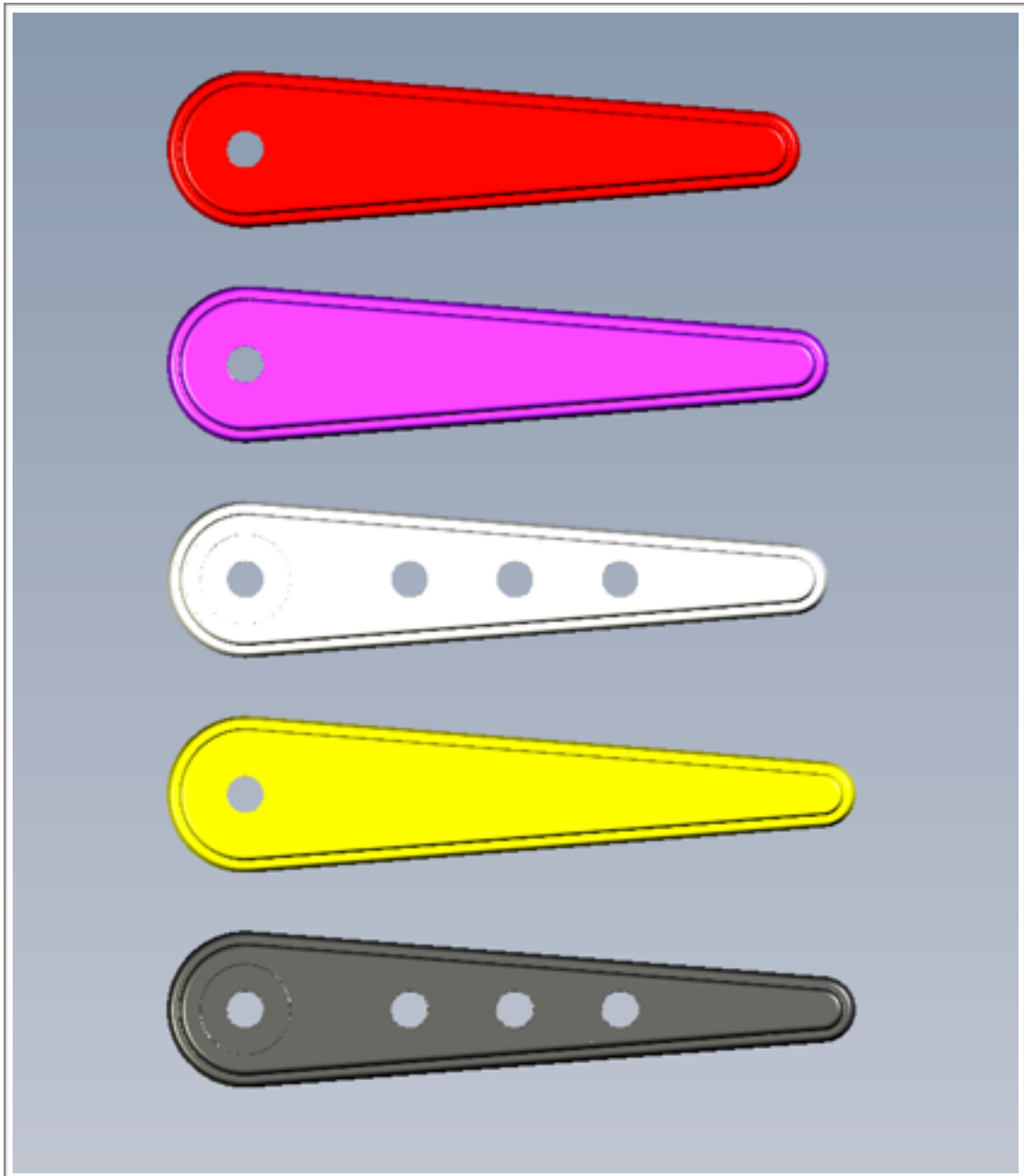

CSF#4 - Bat and **CSF#6 - Bat** require the **CSF#11 Fake Bulb** to be inserted for that PKE Meter look. The fake Bulb set but be held in place either via glue or taping the 2 holes in the bats. So to prep the bats for Fake Bulb sets screw fastened you tap M3.

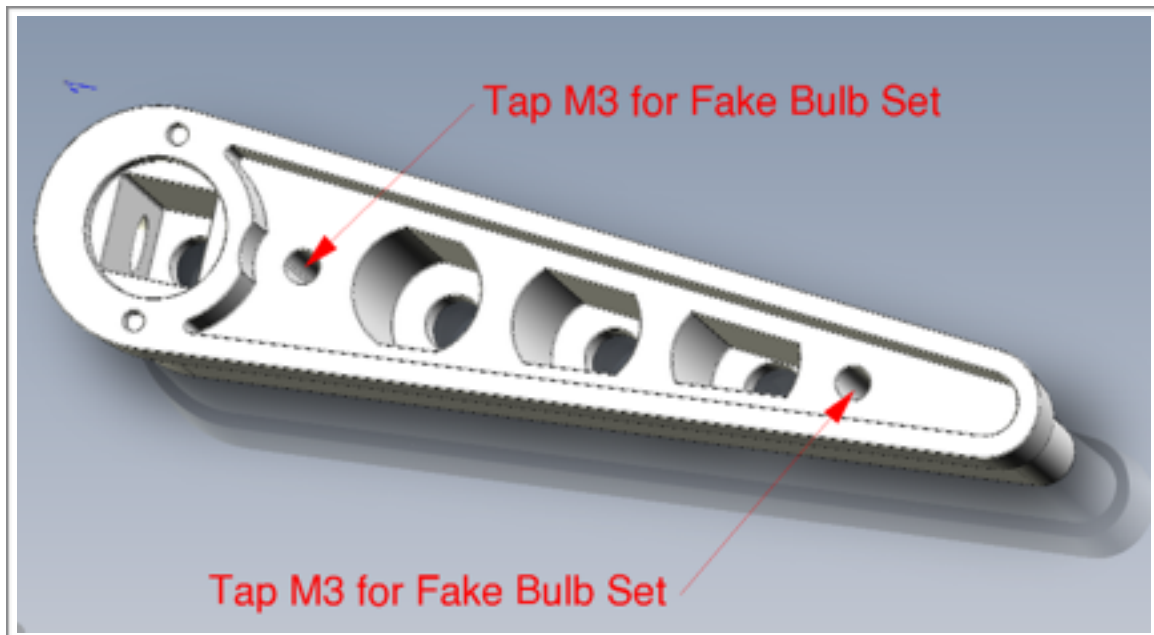

CSF#8 - Button GB Set just requires you to trim the linking stick as the part was too small for a individual print. The stick is on the underside and will not be seen as when trimmed in will expose the non died colour - white.

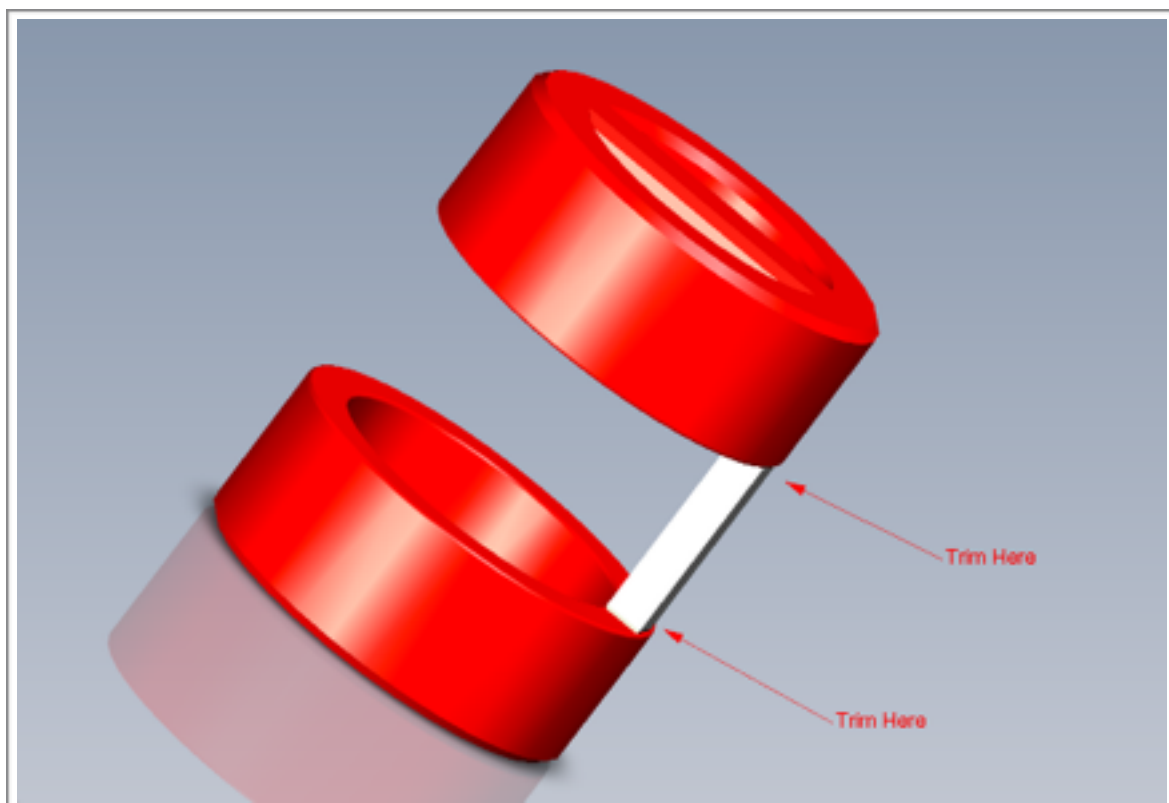

Assembly to Game

1. Assemble a flipper bat set ready for the installation.
2. Fit the flipper bat set to the flipper mechs and set height and alignment to the inland guides as you would any other flipper bat.
3. Once the flipper bat set is fitted to a game now you don't have to lift the playfield to swap out bats. Simply loosen the bat from its post via the top screw. Each bat regardless of 2 7/8", 3" and 3 1/8" bat all have the same design so swapping out the various length bats will not affect the alignment.
4. Drop in the new set of bats or keep the current ones in and re-fasten the screws to lock in the bat to the post.
5. The Button caps is a option item and can be pressed in, or use a little bit of glue or double sided tape - just don't go too permanent otherwise you won't be able to remove them later on.

Note: the bats can be removed and the posts can stay installed to the flipper mech and then you can remove the whole mech as the post fits through the typical playfield clearance hole allowing you to remove the mech from the playfield allowing you to service the mech on the bench.

Game Fun

- For Tournaments or Pinball Olympics you can now add the shortest bats to Trudeau games for the extra width flipper gap, or a 2 7/8" on one side and 3 1/8" bat on the other side for some funky unbalanced playing.
- Add 3 1/8" bats to Trudeau games to tighten up the gap for those not enjoying the wide gap allowing you to swap out in minutes to suit a kids part and then back to 3" for a guys tournament session.
- Swap out colours in a matter of minutes.
- Add feature bats - Flipper topper versions coming soon using the same posts and aiming to use the same bat as the Ghostbuster PKE bat.

Flipper Set 1 - 2/ 7/8” Long Bats

Identifier - 1 dot on the under side

Assembled Set - render

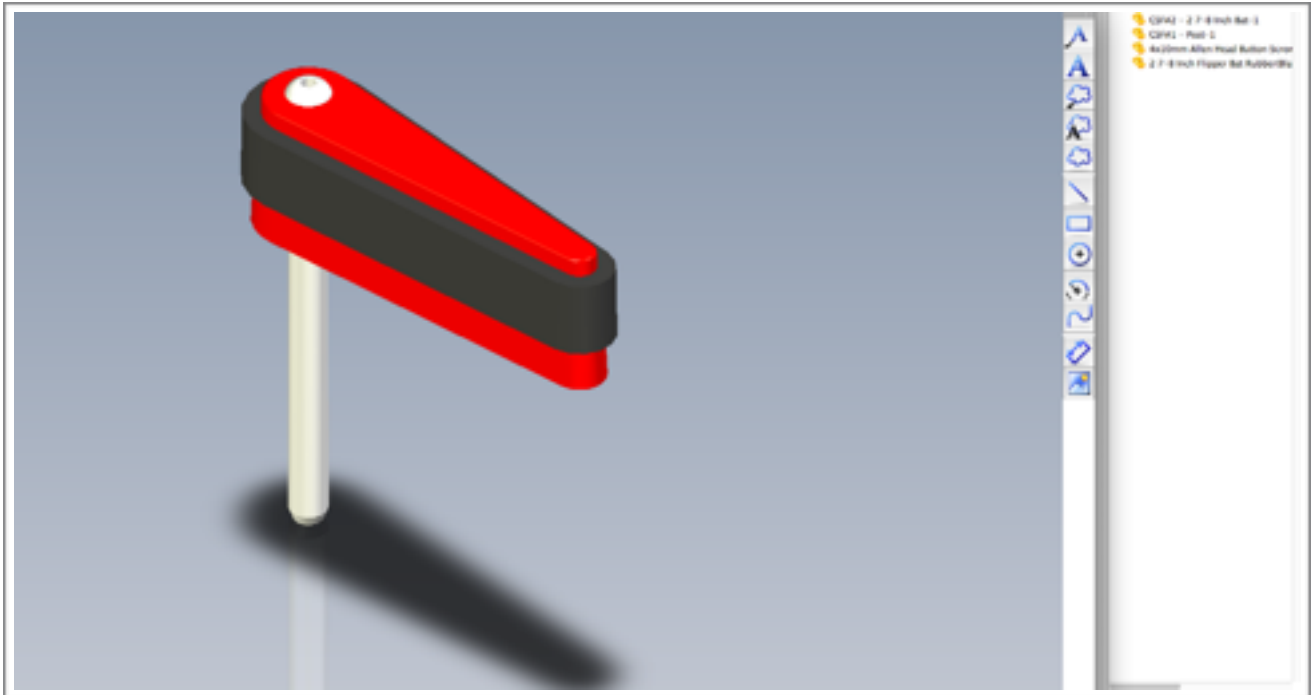

Flipper Set 2 - 3" Long Bats

Identifier - 2 dots on the under side

Assembled Set - render

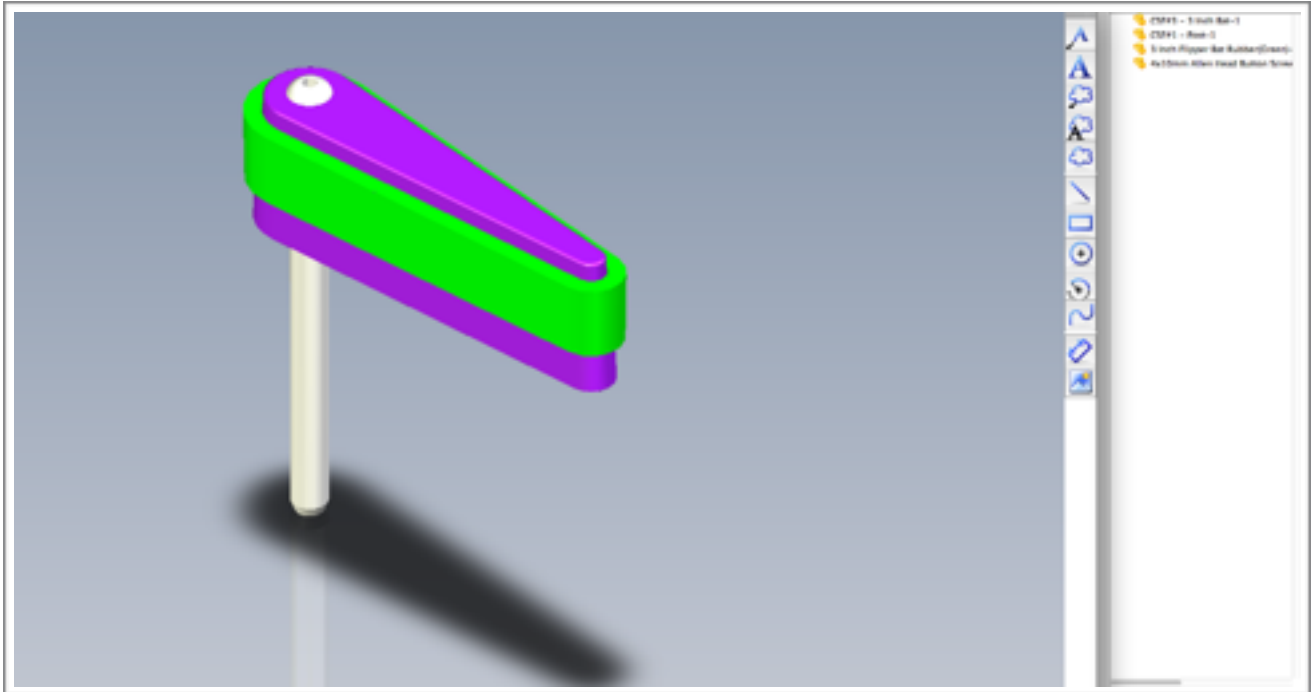

Flipper Set 3 - 3" Ghostbusters PKE Long Bats

Identifier - 2 dots on the under side

Assembled Set - render

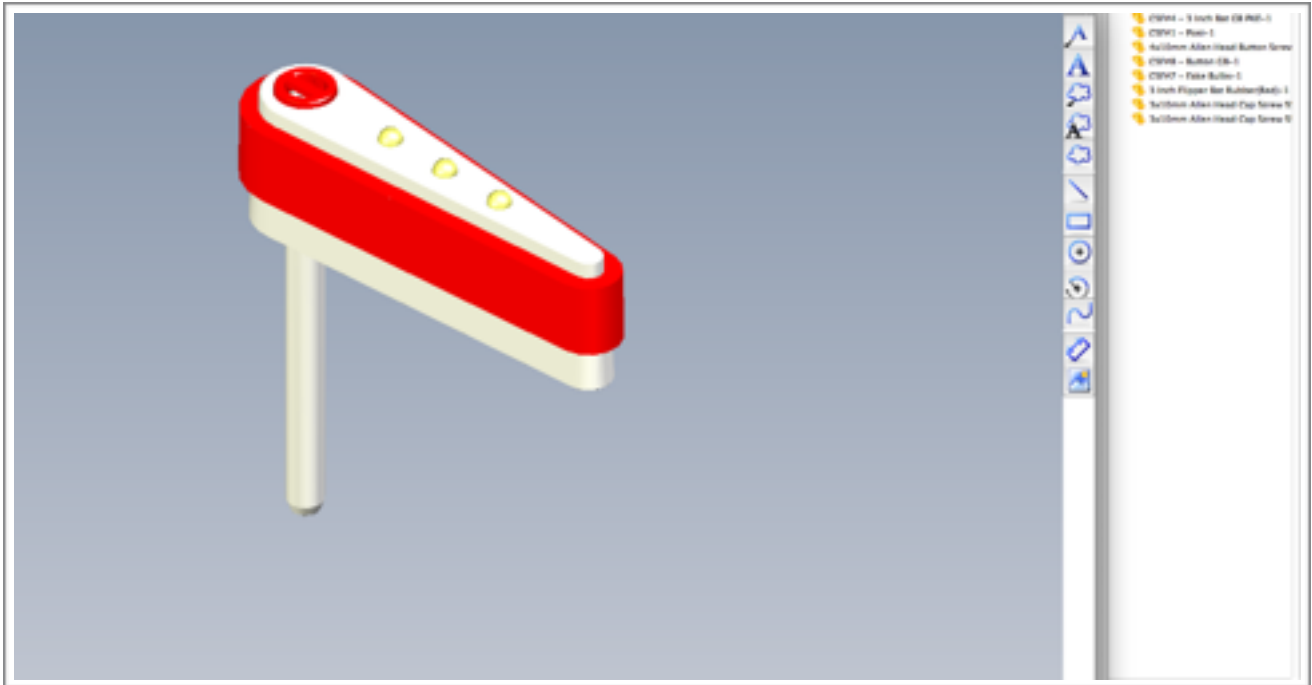

Separated Set - render

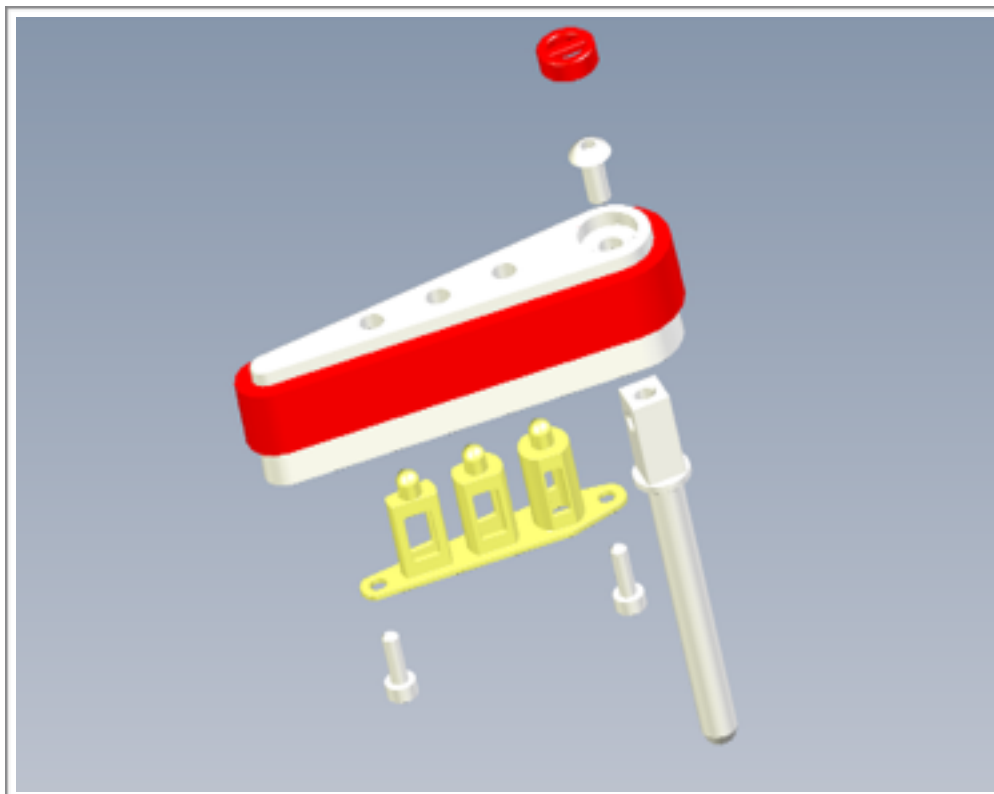

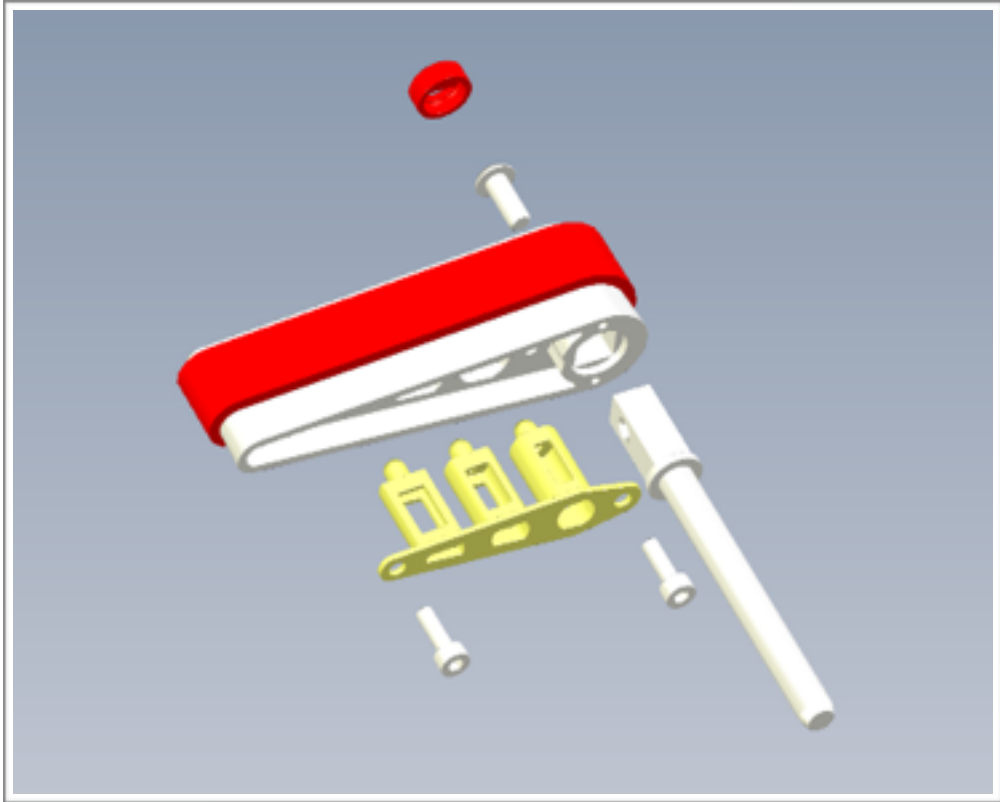

Flipper Set 4 - 3 1/8" Long Bats

Identifier - 3 dots on the under side

Assembled Set - render

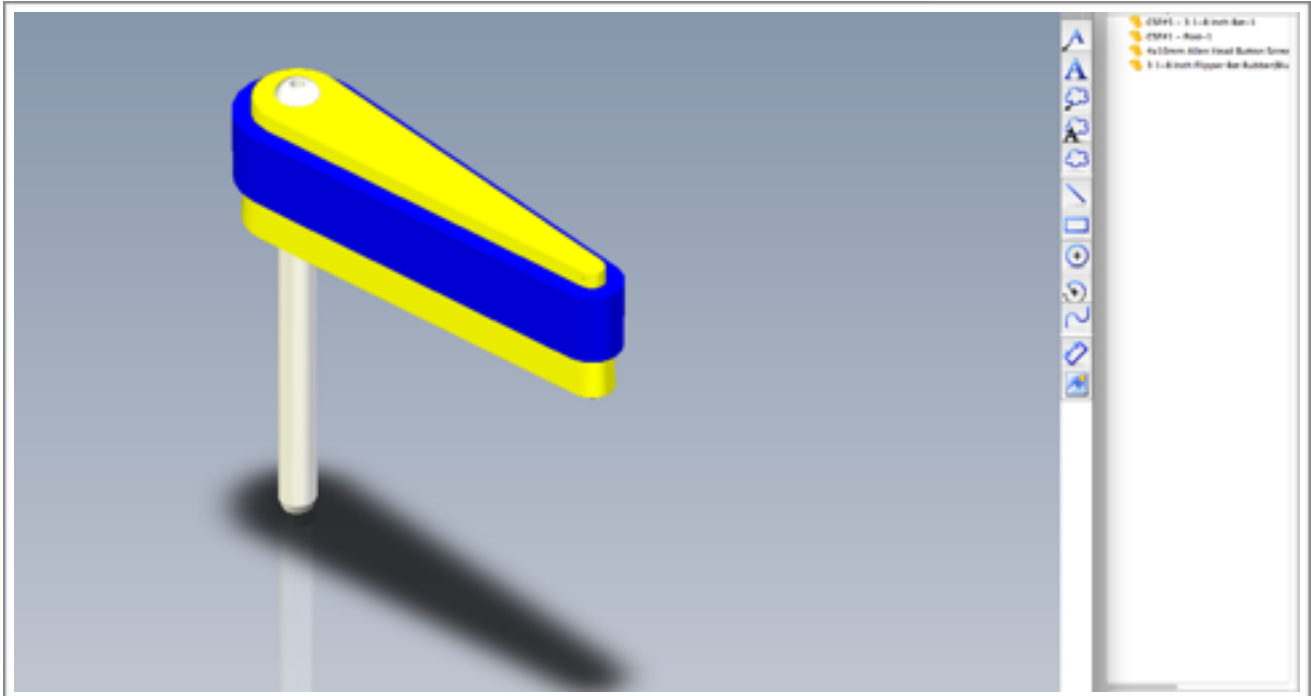

Separated Set - render

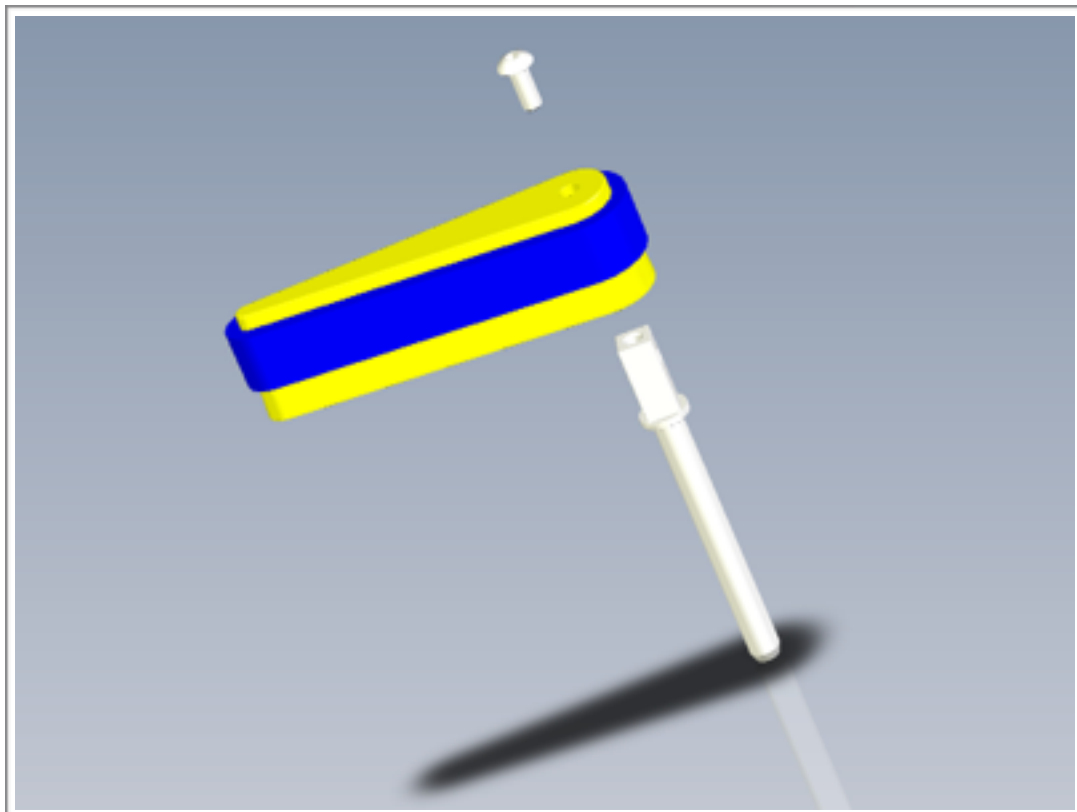

Flipper Set 5 - 3 1/8" Ghostbusters PKE Long Bats

Identifier - 3 dots on the under side

Assembled Set - render

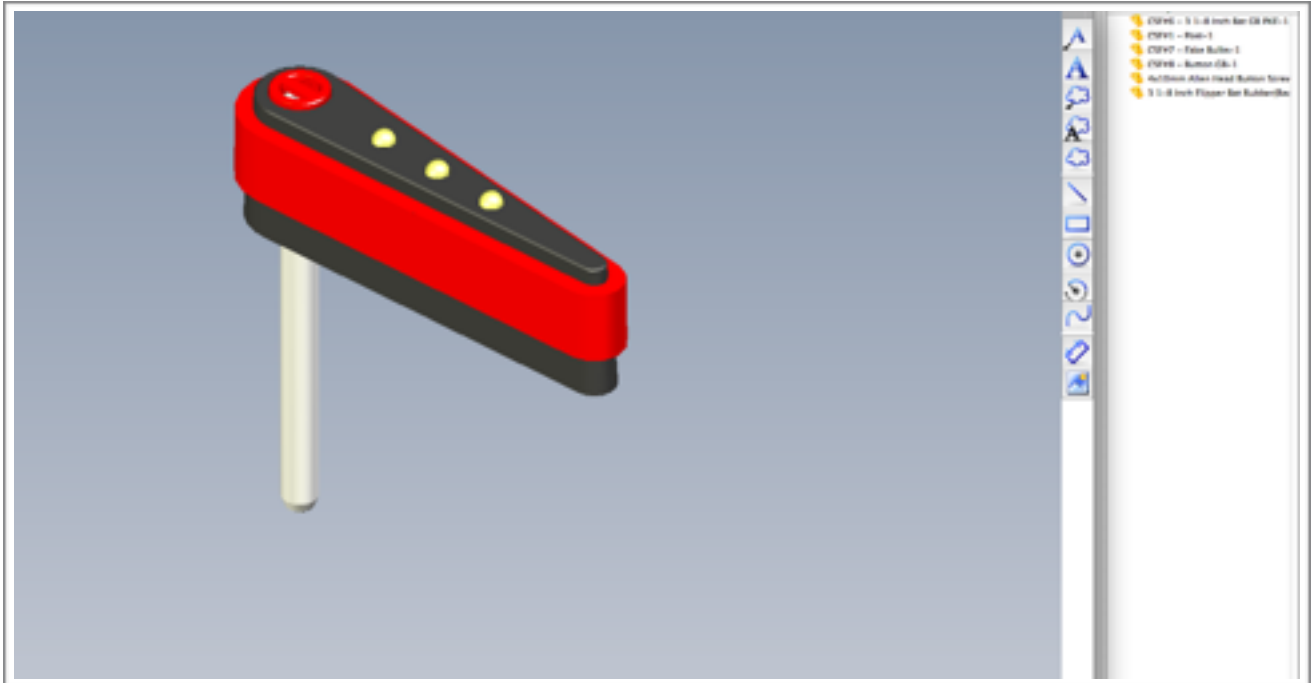

FAQ

Q. - What is the weight comparison?

A - Regular WMS bats weigh **27 grams** (not including the rubber), Pinball Life Aluminium bats weigh **48 grams** (not including the rubber) and Swinks Bats weigh approximately (not including the rubber):

2 7/8" bat (no rubber) - **34 grams**

3" bat (no rubber) - **34.5 grams**

3" GB bat (no rubber) - **38 grams**

3 1/8" bat (no rubber) - **35 grams**

3 1/8" bat (no rubber) - **36 grams**

Note: weights calculated for the redesign bats are based on the models in Solidworks - which are very accurate.

Q. - Have these been tested?

A - Currently I only have one game so have had a 3" bat set installed in a CFTBL since Jan 2016 and put up over 250 games with no problems at all - but not long term tested so available as prototype designs. I have put it out there for 2 people to be testers where I will refund all royalties and supply hardware and taps for free including post - they just need to purchase the Shapeways parts.

Q. - How long does it take to swap out just the bats?

A. - Once installed and you want to swap out the bats, simply slide the glass off and remove the 2 retaining screws, lift the bats off, install the new ones and refit the screws - 5 minutes max.

Q. - Why are these so different priced compared to regular bats?

A - The price is different for a number of reasons, but basically these are being made as one off's compared to mass produced resulting in raised prices. Off the shelf bats will be around the \$10 a set on average where these will vary from \$75 - \$100 depending on the options selected. As a mod they are reasonably priced but compared to the readily available commonly available bat these may appear overpriced. As for the price 80% is Shapeways and 20% is my royalty payment.

Q. - What is the advantage of these bats over normal bats?

A. - The advantage is you can swap out bat colours or lengths or even feature bats in minutes and anyone can do it even a non mechanically minded person.

Q. - Are there any designs being released in the future?

A. - Yes there will be toppers that can fit hopefully to the Ghostbusters style of bats like a car fender chrome trim or proton gun, as well as many other ideas in the future - depends if people support these. There will also (all going well) lighting kits that will light up when activated (flipped) which will house a small battery in them.

Q. - What are the posts made out of?

A. - 3D printed stainless steel infused with bronze.

Q. - What are the bats made out of?

A. - 3D printed / laser sintered Nylon with all walls being solid, not honeycomb link a home 3D printer print and these take a lot of punishment.

Q. - What rubber fits on the 2 7/8" and 3 1/8" bats.

A. - I have been using the Pinball Life Perfect Play rubbers and do not use the other brand that is super tight on regular 3" bats (Super Bands I think) as these would be impossible to put on the 3 1/8" bats.

Q. - Why not get some regular posts machined up to reduce the costs?

A. - What minor savings I would gain would be lost when posted from Australia to around the world.

Q. - Why Shapeways?

A. - Because they are based in New York, USA and postage around the US is \$5 where as if the parts came to me to be tapped and sent back to you they would cost another \$35 = too much and no sales.

Q. - Would you be open to someone buying a large quantity of parts and finishing them off in the USA and being a reseller so to speak?

A. - I am totally open to this and would be more than happy to send a pack of 100 screws, taps and allen keys at cost so others can enjoy the possibilities.

Q. - Why did you do this if they are expensive?

A. - I did this more for the challenge but would love to see people enjoy them.

RETURN POLICY:

These are a non refundable mod / design and purchased from a separate company to Swinks. Though please contact us as we will be proactive to try and quickly resolve any problems where possible.

PRODUCT DISCLAIMER:

Please remember that this is a "MOD." We took great effort in designing and testing our system in order to produce a high quality product, but it is not a factory original or an approved part for your pinball machine. There is the risk of unwanted side effects with any modification to a factory game and there are many factors that can cause undesirable side effects after installation of such a modification. As such, we cannot assume responsibility for game malfunction, damage to the game or surroundings, unwanted electrical emissions, personal injury, or other adverse effects caused by the installation of our MOD. Please remove a bat assembly if it fails immediately to avoid damage to your game / play field and ensure the post is securely locked in place and not slip down in play.

PRODUCT QUALITY DISCLAIMER:

All parts are made to the highest quality possible via Shapeways and you may have some visible print lines which are different to a home printer. Occasionally Shapeways quality does drop so if you are not satisfied make sure to contact Shapeways promptly as they will replace the item after a review of photos. You may notice these print lines when handling but once the mod is installed they will not be clearly visible from the players perspective. In downloading this manual and purchasing the mod you are accepting the finish quality of this relatively affordable mod.