

R.O.W. = ROLL-OVER WIRE FORM
 S.U. = STAND-UP TARGET
 D.T. = DROP TARGET

PLAYFIELD

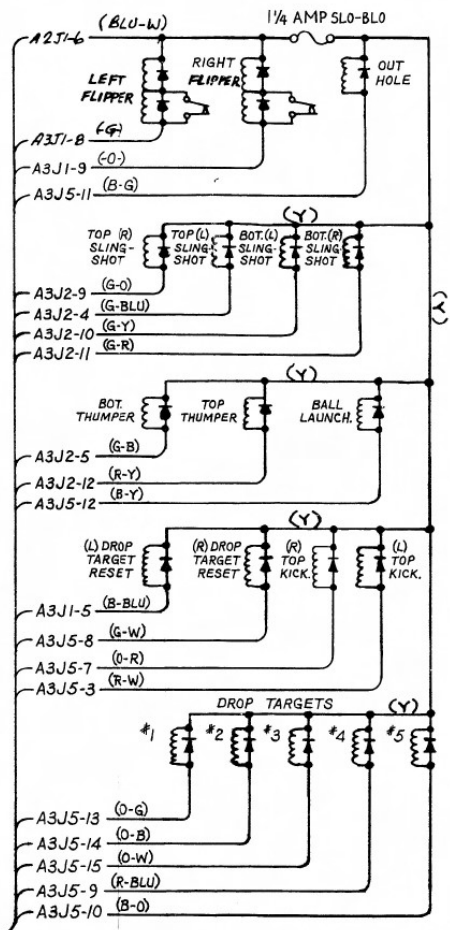

FLIGHT 2000

DESCRIPTION	WIRE COLOR	JACK LDA	PIN NO.
B ROLL-OVER BOTTOM LEFT	W-BLU	J3	3
L ROLL-OVER TOP	W-GREY	J3	23
A ROLL-OVER TOP	GREY-BLU	J1	10
S ROLL-OVER TOP	GREY-Y	J1	15
T ROLL-OVER TOP	R-W	J3	4
O ROLL-OVER TOP	R-B	J3	16
F ROLL-OVER BOTTOM LEFT	GREY-O	J1	14
PUR-W	PUR-W	J1	2
BONUS 1,000	BRN-B	J1	18
BONUS 2,000	BLU-R	J1	1
BONUS 3,000	BRN	J3	26
BONUS 4,000	G-R	J3	1
BONUS 5,000	GREY-G	J1	19
BONUS 6,000	GREY	J1	9
BONUS 7,000	R-Y	J3	25
BONUS 8,000	O-G	J3	12
BONUS 9,000	PUR	J1	17
BONUS 10,000	G-B	J1	8
BONUS MULTIPLIER 1X	W-B	J3	15
BONUS MULTIPLIER 2X	BLU-W	J1	23
BONUS MULTIPLIER 3X	R-G	J1	3
BONUS MULTIPLIER 4X	W-BLU	J3	17
BONUS MULTIPLIER 5X	Y	J3	11
FIRST STAGE GO LEFT	Y-BLU	J2	7
FIRST STAGE GO TOP	Y-BLU	J2	7
GAME OVER	GREY-W	J2	11
HIGH SCORE TO DATE	GREY-O	J2	22
LEFT HAND CORNER B	Y-G	J3	02
LEFT HAND CORNER L	W-BLU	J1	13
LEFT HAND CORNER A	BRN-R	J1	6
LEFT HAND CORNER S	B-W	J1	28
LEFT HAND CORNER T	R-W	J3	4
LEFT HAND CORNER O	O-W	J3	27
LEFT HAND CORNER F	Y-G	J1	7
LEFT HAND CORNER F	B	J1	16
MATCH	GREY-Y	J2	1
RELEASE NEXT ROCKET	B-R	J3	19
RIGHT BANK	BRN-BLU	J1	24
RIGHT SPINNER -500	PUR-B	J1	4
RIGHT SPINNER -1,000	R	J3	22
RIGHT SPINNER -1,500	B	J3	13
RIGHT SPINNER -2,000	W-BRN	J1	27
SECOND STAGE GO LEFT	W-BLU	J2	5
SECOND STAGE GO TOP	W-BLU	J2	5
SHOOT AGAIN (BACKBOX)	GREY-R	J2	21
SHOOT AGAIN (PLAYFIELD)	GREY-R	J1	26
SPECIAL LANE	W	J2	16
SPECIAL LANE TOP	PUR-W	J2	30
SPECIAL OUT LANE LEFT	W-G	J2	15
SPECIAL OUT LANE RIGHT	G-W	J2	14
SPOT BLAST	G-B	J3	21
TILT	GREY-B	J2	10
#1 AT 5 BANK	GREY-B	J3	10
#2 AT 5 BANK	PUR-B	J1	25
#3 AT 5 BANK	B-O	J1	11
#4 AT 5 BANK	W-O	J3	20
#5 AT 5 BANK	R-BLU	J3	18
ALL SYSTEMS GO LEFT	BLU-Y	J2	20
ALL SYSTEMS GO TOP	BRN-O	J1	12
LEFT SPINNER	BLU-O	J1	05

A2J5-7(BLU) FEATURE LAMP BUS
 A2J5-3(BLU)