

Jan. 7, 1936.

A. S. MOORMAN

2,027,244

BALL ROLLING GAME

Filed Oct. 5, 1933

3 Sheets-Sheet 1

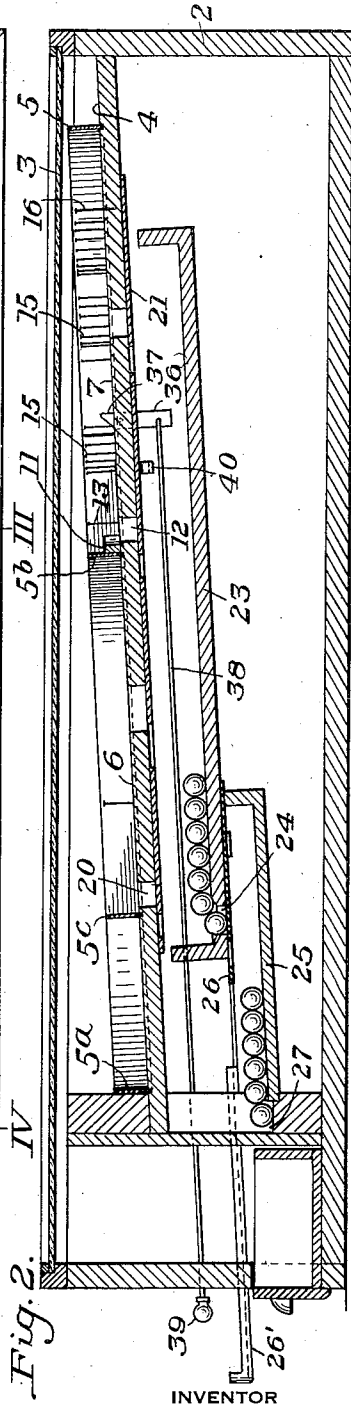
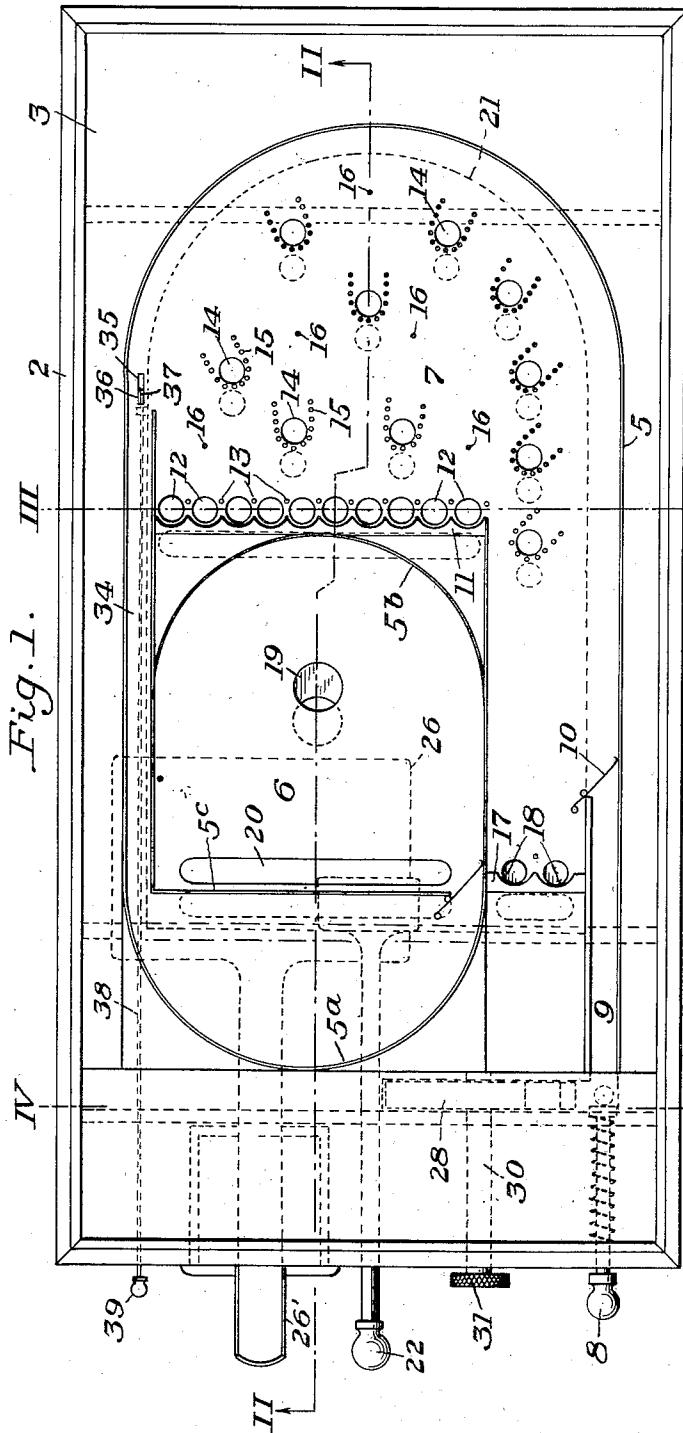

INVENTOR  
Albert S. Moorman  
By his atty  
Byrnes, Stabbin, Parmelee & Blenko

Jan. 7, 1936.

A. S. MOORMAN

2,027,244

BALL ROLLING GAME

Filed Oct. 5, 1933

3 Sheets-Sheet 2

Fig. 3.

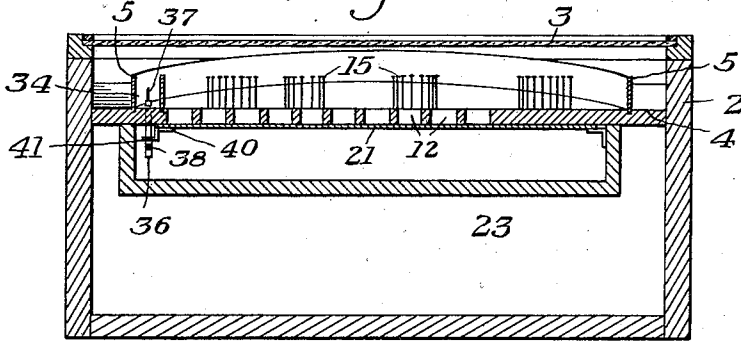

Fig. 4.

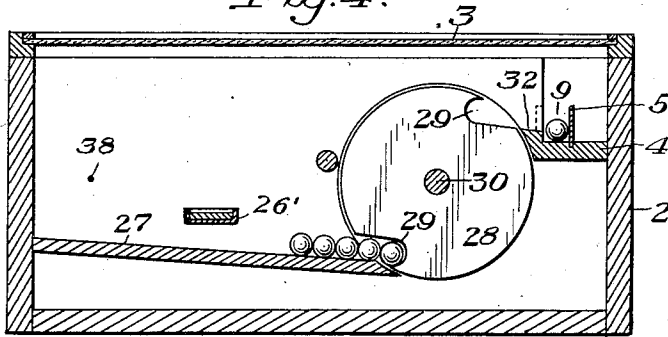

Fig. 5.

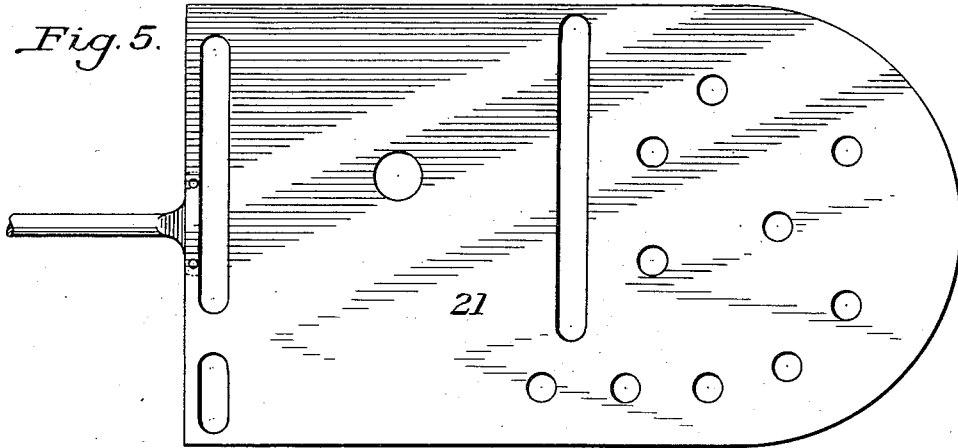
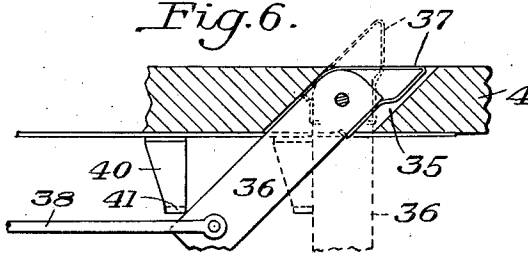

Fig. 6.



INVENTOR

Albert S. Moorman  
by his atty

Rymer, Stebbins, Parmelee & Banker

Jan. 7, 1936.

A. S. MOORMAN

2,027,244

BALL ROLLING GAME

Filed Oct. 5, 1933

3 Sheets-Sheet 3

Fig. 7.

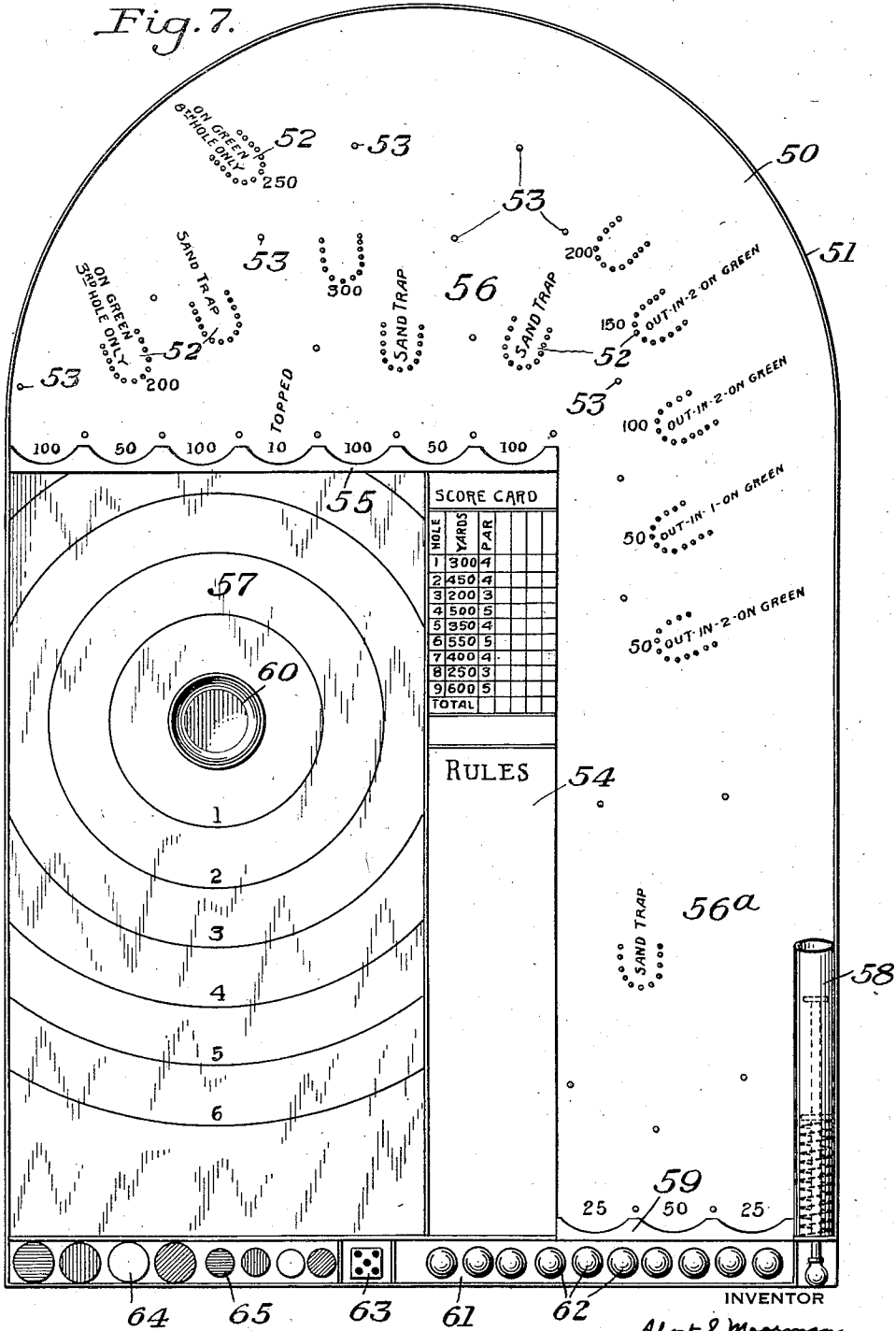

SCORE CARD

HOLE	YARDS	PAR	
1	300	4	
2	450	4	
3	200	3	
4	500	5	
5	350	4	
6	550	5	
7	400	4	
8	250	3	
9	600	5	
TOTAL			

RULES

INVENTOR  
*Albert S. Moorman*  
 by his attys  
*Bymes, Stebbins, Parmelee & Blanker*

# UNITED STATES PATENT OFFICE

2,027,244

## BALL ROLLING GAME

Albert S. Moorman, New York, N. Y.

Application October 5, 1933, Serial No. 692,282

7 Claims. (Cl. 273—121)

This invention relates to games of the so-called "bagatelle" type in which a game board is provided with a shooter by means of which balls may be propelled over the surface of an inclined game board, the game board being provided with a plurality of pins and pockets, the pins being for the purpose of deflecting the balls while the pockets are for the purpose of receiving them, the object being to get the balls into certain desired pockets for the purpose of scoring or playing the game. Game boards of this general type and of the various designs are generally known.

According to the present invention, there is provided a game board of this general type having a plurality of playing fields differently arranged but co-related in such manner that the bagatelle game may be played in the conventional fashion or whereby the game can be modified to provide a play simulating the playing of golf.

In accordance with the present invention, the balls can first be played on the primary playing field to simulate the play on the fairway of a golf course, and the secondary playing field is thereafter used to complete the play simulating the putting of the ball on the green in a game of golf.

The invention may be readily understood by reference to the accompanying drawings which illustrate certain embodiments of my invention, and it will be understood that these are merely illustrative of the invention and that the invention is not confined to the particular construction and arrangements therein disclosed.

In the drawings:

Figure 1 represents a plan view of a preferred embodiment of the invention, the drawing however, omitting those legends (shown in Fig. 7) according to which the game may be adapted to play simulating the playing of golf;

Figure 2 is a longitudinal section in the plane of line II—II of Fig. 1;

Figure 3 is a transverse vertical section in the plane of line III—III of Fig. 1;

Figure 4 is a similar view in the plane of line IV—IV of Fig. 1;

Figure 5 is a plan view of the bottom slide plate apart from the rest of the machine;

Figure 6 is a detail view showing a movable ball pin forming a part of the game board of Fig. 1; and

Figure 7 is a plan view on a slightly larger scale showing a modified playing board and showing legends on the game board for use in playing a game simulating the playing of golf, and which

legends can also preferably be applied to the game board of Fig. 1.

Referring first to the construction shown in Figs. 1 to 6, the game comprises a casing or frame 2 having a glass cover 3. Spaced below the glass cover 3 is a playing surface 4 comprising a smooth inclined board or other surface having an upstanding guide strip 5 thereon which extends up one side of the board, is curved across the top of the board, extends down the other side of the board, is curved on a shorter radius near the bottom of the board as indicated at 5a, this flange then looping around as indicated at 5b to enclose the secondary playing field 6, the primary playing field partly surrounding the secondary field 6 and being indicated generally by the reference numeral 7.

The playing board 4 is inclined upwardly from one end toward the other, and at the lower end thereof, preferably at the right-hand corner, there is a ball shooting plunger of the conventional type, this ball shooter being designated generally as 8 and being of the type wherein by pulling back on the operating knob a spring is compressed which, upon releasing the knob, moves the plunger forwardly to shoot the ball. Extending forwardly of the shooter is a runway, designated 9, and there is preferably a swinging gate 10 across the exit of this runway, this gate being of a type commonly employed on toys of this nature and comprising a wire pivotally supported about a small nail so as to swing out when hit by a ball travelling up the runway, and to drop back to the position shown to prevent the ball from reentering the runway. At the front of the secondary playing field 6 is a transverse partition extending part way across the main playing surface 7, this partition being designated 11 and having a series of notches on the face thereof. The playing board 4 is provided with a plurality of holes 12, each hole being positioned directly in front of a notch. Intermediate the holes are pins 13 for deflecting the rolling balls into one notch or another. These notches may be marked with numerals in the manner shown on correspondingly positioned notches in Fig. 7. Positioned elsewhere over the main playing surface 7 are a plurality of scattered holes 14, these holes being partly surrounded by rows of upstanding nails 15, these nails forming wickets or pockets about the holes in the manner well known to those skilled in the art. These holes may also be marked with numerals and indicia in the manner also illustrated in Fig. 7. Scattered over the main play-

ing surface 7 are upstanding pins 16 forming baffles with which the rolling balls may contact to deflect their course.

In addition to the holes or pockets 12 and 14, there is provided between the runway 9 and the margin of the secondary playing field 6 a back wall 17 having one or more pockets 18 at the front thereof, similar to the pockets 12, two of these pockets being shown in Fig. 1. These pockets comprise notches formed in the back wall and holes passing through the playing board.

In the secondary playing field there is a single central opening 19, and along the back wall 5c of this field there is a single slot 20 through the playing board. It is customary in game boards of this nature to provide some means under the playing board to prevent the balls from falling completely through the scoring holes or pockets until the play has been completed. Such a means is provided in the present board, and it comprises a thin plate 21 slidably supported at the bottom of the playing board 4. As shown in Fig. 5, this plate 21 is provided with numerous holes and slots which are normally out of register with the holes in the playing board 4, but which may be brought into register therewith by pushing forwardly on an operating extension 22 at the rear of the board. Spaced below the plate 21 is a receiving board 23 onto which the balls fall when they drop through the registering openings in the playing board and the plate 21. The board 23 is sloped toward the rear of the casing, and it is provided with a discharge opening 24 through which the balls can roll by gravity into a receiving trough 25. The movement of the balls through the hole 24 into the receiving trough 25 is governed by the sliding gate 26 operated from an extension 26' at the rear of the casing. When desired, the member 26' may be a conventional coin-controlled device.

When the balls roll down the receiving trough 25, they pass into a transversely extending trough or runway 27 (see Fig. 4). At the lower end of the trough or runway 27 is an elevator wheel 28, this wheel comprising a disc having pockets 29 in the periphery thereof, which pockets are large enough to accommodate only a single ball. The disc 28 is carried on a shaft 30, the rear end of which projects beyond the rear of the casing and is provided with an operating knob 31. The wheel 28 is enclosed in the casing, but an inclined surface is provided at the rear of the runway 9, this surface being designated 32, by means of which when the ball has been elevated through the rotation of the disc 28 it may roll from the pocket down the surface 32 into the runway 9 to a position in front of the plunger 8. In this way the balls can be moved one at a time into playing position in front of the plunger. After all of the balls on the trough or runway 27 have been played, the sliding plate 21 is operated to permit the balls which have been placed in the various pockets to drop through onto the receiving board 23, from whence they may be again put into play through the operation of the gate 26.

Along the longitudinal side of the board opposite the side on which the shooter is located there is a relatively long runway 34, the upper end of which terminates in the playing field 7 and the lower or rear end of which terminates at the back wall 5c of the secondary playing field 6. This runway is formed by the various convolutions of the upstanding strip 5. In the board 4 at the forward end of the runway 34 is a slot 35, which slot is shown in detail in Fig. 6.

Pivotaly mounted in the slot is a lever 36 which projects below the board 4 and which has a wire finger or pin 37 formed thereon, this wire pin or finger being bent to such shape that when the lever is in the vertical position shown by the dotted lines in Fig. 6, the finger 37 will be upright and form an obstacle to prevent the balls from passing down the runway 34. By rocking the lever 36 to the inclined position shown in full lines in Fig. 6, the finger 37 is flush with the top of the playing surface so that balls can roll over it into the runway 34. Means is provided for operating this finger or pin 37 at will. This means comprises an operating rod 38 connected to the lower end of the lever 36 and passing back through the rear end of the casing, the end of the rod being provided with an operating knob 39. By reciprocation of the rod 38 the lever 36 can be moved to the positions shown. Also, it is desirable that when the play is initiated the pin 37 shall be standing up in the ball obstructing position, and shall be retracted to its inoperative position only after a predetermined number of balls have been played into predetermined holes or pockets on the main playing board. In order to insure that the pin be in the ball obstructing position when the play is initiated, the sliding plate 21 carries a lug or bracket 40 on its under surface, this lug carrying a finger 41 arranged to contact with the lever 36. When the plate 21 is back in its normal position, the finger 41 is clear of the lever 36 and the lever 36 can be operated at will. When the plate 21 is shoved forward to clear the board of balls, the finger 41 engages the lever 36, pushing the lever to the dotted line position shown in Fig. 6. Thus the pin is automatically set up each time the board is cleared, and it has to be retracted by manual operation of the knob 39.

By reason of the presence of the retractible pin 37, the secondary playing field 6 can be used or not at the option of the player.

As stated above, the pockets of the primary playing surface are preferably marked with indicia similar to that shown in Fig. 7, and there is also available in connection with the game a table having indicia simulating a golf score similar to that indicated in Fig. 7.

When it is desired to play the game of bagatelle in the usual way, the secondary playing field need not be used and the operation of the game will be readily understood, the ball being shot into the different pockets of the primary playing surface. In playing a game simulating the game of golf the players use a score card similar to that shown in Fig. 7 which gives the yardages arbitrarily designating a hypothetical golf course, together with a hypothetical par score for the various holes of the course. Taking as an example the first hole of Fig. 7, it is noted that the first hole is 300 yards. The player shoots the first ball and it may be assumed that the ball rolls into one of the pockets marked 200. This means that on his "drive" he has played the ball 200 yards. He shoots the next ball, which for purpose of illustration, may be assumed to go into one of the holes or pockets marked 100. This second "stroke" thus puts him on the "green." He then retracts the movable pin 37 to its inoperative position and in his next play he shoots the ball hard in order that it will follow around the guide rail 5, roll down the runway 34, circle around the portion 5a of the guide rail, and enter the secondary playing field 6. If this ball goes into the central hole or pocket 19, the player has made his "putt" 75

and his score for the hole is one under par. If, however, the ball goes into the slot 20, he has missed his putt and must shoot another ball and continue to do so until one goes into the hole 19.

5 The number of balls shot to complete any given hole on the score card indicates the player's number of "strokes" for that hole. Since the players can control their shots very considerably by their manipulation of the shooter or plunger 8, the game provides a game of skill which simulates to

10 a considerable extent the playing of golf.

It will be observed by reference to Fig. 7 that some of the pockets are designated as hazards, and if a ball is played into one of the hazards the player may then shoot for those pockets which are appropriately marked to indicate playing out of the hazard. If the player overshoots the green, according to the hypothetical yardage, he will play the ball into one of the other pockets 18, these pockets also being appropriately marked.

15 Not only does the movable pin 37 control the movement of balls into the runway 34, but when this pin is in its upstanding position the players can use it to considerable advantage as an obstacle to bounce the ball against. If the ball is shot from the shooter with considerable force, it will roll around and hit this pin with considerable force and rebound.

20 When a hole of golf is completed by sinking the putt, the board or playing field is cleared of all balls that were shot for said hole by pushing in the knob 22 which drops all the balls out of sight. Now the field is clear of all balls shot for the previous hole and is ready to play the next hole.

25 Referring to Fig. 7, this figure shows a conventional game board of the same general type as the one shown in Fig. 1, but I have shown the board as being a simple board without a casing and without the ball feeding mechanism, the arrangement of Fig. 1 being more generally adapted for commercial amusement purposes, and the arrangement of Fig. 7 being the type of board or game adapted for home use. It will be understood, however, that the idea of Fig. 1 can be incorporated on a simple home playing board of the type shown in Fig. 7, and that the arrangement shown in Fig. 7 can be adapted to use the various mechanisms shown in Fig. 1 for commercial amusement purposes. In Fig. 7 the game board, designated generally as 50, has a marginal flange 51 for retaining the balls on the playing board. Various pockets 52 are formed on the surface of the board, these pockets preferably being formed by small nails arranged in U-shaped formation. Scattered over the surface of the board are obstacle pins 53.

30 The board is provided with a longitudinally extending partition 54 that extends from the rear end of the board to a point past the middle of the board. The board is also provided with a transverse partition 55 which extends part way across the board from the left-hand side to the partition 54. The partitions 54 and 55 serve to separate the primary playing surface 56 from the secondary playing surface or space 57. The ball shooter is located at 58, being in a corner of the board opposite the secondary playing field 57. The primary playing surface 56 is the same shape as that shown in Fig. 1, having a main portion at the top of the board and a leg portion 56a which extends down alongside the partition 54. The back wall 59 at the rear end of this leg is notched to provide a plurality of ball receiving pockets, as indicated. The partition 55 is also

notched to provide a plurality of ball receiving pockets as shown. The secondary playing surface 57 is preferably covered with felt and is provided with a recessed cup 60. Along the rear end of the board there is provided a trough or receptacle 61 adapted to hold the playing pieces comprising the ball 62, a die 63, a shooter or "flipper" 64, and tiddleywinks 65. The partition 54 serves to hold a score card simulating a golf card.

10 In playing a game simulating the game of golf the play is first conducted on the primary playing surface 56 using the balls 62 and the shooter 58. The player shoots the balls at a necessary "yardage" to "put him on the green." When the yardage indicates that he is on the green he throws the die 63 and this indicates which one of the several concentric rings marked on the secondary playing field 57 the player shall put his tiddleywinks in, thereby determining the lie of the "ball" on the "green." Placing the tiddleywinks on this green enables the player to complete the play by using a flipper 64 to get the tiddleywinks in the cup. In this way he "putts" out the play.

15 The form of game provides a game board having co-related playing fields comprising a primary and a secondary field so arranged that the play may be initiated in the primary field and complemented or completed in the secondary field. The indicia on the primary playing field, or the indicia in conjunction with the cups with which the indicia is associated co-relate the play in the primary field to the play in the secondary field. In this respect the board adapts itself to the playing of a game simulating golf because in the game of golf the play is initiated on the fairway and completed on the green. The arrangement of the two fields is such that the full length of the board is available for the shooting of the ball and the full width of the upper part of the board is available for the roll of the ball to different pockets. The secondary field, therefore, is so located that it does not impair the area of the primary field over which play is desirable.

20 While I have shown and specifically described certain embodiments of my invention, it will be understood that this is intended by way of illustration and that various changes and modifications may be made in the construction and arrangement of the particular parts within the contemplation of my invention and, as previously indicated, the board arrangement of Fig. 1 can be used in a simple form of home playing board as shown in Fig. 7, while the board layout of Fig. 7 may be used with mechanisms of the type shown in Fig. 1 for automatically removing the balls from the playing surface and for returning them one by one to the shooter.

I claim:

1. In a ball rolling game of the class described, a playing board having a ball shooter, said board having a primary playing field and a secondary playing field, a passage connecting said fields, a manually operable gate in said passage, said gate comprising a pin, a lever on which the pin is carried, and means for moving the lever to rock the pin from an upright position to a horizontal position, the board having a slot therein to receive the pin in a horizontal position whereby the pin is removed entirely out of the path of the balls when it is in the horizontal position.
2. A game board of the class described comprising an elongated playing surface having a rounded flange at its upper end, said board having the

- playing surface thereof divided into a primary playing field and a secondary playing field, the primary playing field extending across the top and down along one side of the secondary playing field, there being a runway for balls from the top of the primary playing field down the opposite side of the secondary playing field opening into the secondary playing field, and a movable gate at the entrance of said runway.
3. A game board of the class described comprising an elongated playing surface having a rounded flange at its upper end, said board having the playing surface thereof divided into a primary playing field and a secondary playing field, the primary playing field extending across the top and down along one side of the secondary playing field, there being a runway for balls from the top of the primary playing field down the opposite side of the secondary playing field opening into the secondary playing field, and a movable gate at the entrance of said runway, the primary playing surface having a plurality of ball pockets thereon and the secondary playing surface having a single objective pocket thereon.
4. A golf game apparatus, comprising a game board having a primary playing field simulating the play of a game on the fairway of a golf course and a secondary playing field simulating the putting on the green in the game of golf, said primary playing field having pockets representative of plays on the fairway and said second playing field having a pocket representative of the "hole" in a putting green, said board having a ball guiding runway establishing communication between the two playing fields, whereby a ball may pass direct through the fairway playing field on into the putting green playing field, a shiftable gate member at the entrance to said runway operative to hold the balls to the fairway playing field in one position and to pass the balls on to the putting green playing field in another position and a ball shooter on the primary fairway playing field.
5. Golf game playing apparatus, comprising a game board having primary and secondary playing fields, one of said playing fields simulating a putting green and having a single cup simulating the hole in a game of golf, the other playing field having ball holding devices simulating the play on the fairway of a golf course, a ball shooter for driving balls onto one of said playing fields, a ball guiding runway establishing communication between the two playing fields and a gate member at the head of said runway shiftable to permit entry of the balls from one playing field into said runway or to confine balls to said mentioned playing field and whereby plays simulating the plays on the fairways of a golf course may first be effected and then after shifting the gate member plays simulating the putting the ball in the cup be effected.
6. A game board having two different playing fields with scoring devices thereon, a shooter for driving balls over either playing field into cooperative relation with said scoring devices, said playing fields being successively placed with respect to said shooter, a runway for passage of balls from the shooter to the furthest playing field and a movable gate hingedly mounted on said game board at the entrance to said runway and having two positions on said board, to permit passage of the balls from said shooter through said runway to said furthest playing field or to obstruct passage of balls into said runway and confine them to the nearer playing field.
7. A game board having two different playing fields with scoring devices thereon, a shooter for driving balls over either playing field into cooperative relation with said scoring devices, said playing fields being successively placed with respect to said shooter, a runway for passage of balls from the shooter to the furthest playing field and a movable gate hingedly mounted on said game board at the entrance to said runway and having two positions on said board, to permit passage of the balls from said shooter through said runway to said furthest playing field or to obstruct passage of balls into said runway and to confine them to the nearer playing field, said movable gate consisting of a shiftable rebound abutment for the balls.

ALBERT S. MOORMAN.