

Driver 1

Multimorphic PD-16 (PCBA-0002-0002)



J1 Logic Power		
1	+5v	Red
2	GND	Blk

J2 Not Used		
-------------	--	--

J3 Coil Feed Bank A		
1	Output	Vio
2	Not Used	
3	Key	

J4 Coil Feed Bank B		
1	Output	Org
2	Not Used	
3	Key	

J5 Input Power Bank A		
1	+48v	Org
2	Key	
3	GND	Blk

J6 Input Power Bank B		
1	+48v	Org
2	Key	
3	GND	Blk

J7 Coil Drivers Bank A		
1	Left Slingshot	Vio/Wht
2	Key	
3	Drop Target 3 Reset	Vio/Gry
4	UR Flipper Power	Vio/Blk
5	Drop Target 2 Reset	Vio/Red
6	UR Flipper Hold	Vio/Grn
7	?	Vio/Blu
8	Loop Magnet	Blu/Gry
9	Not Used	

J8 Not Used		
-------------	--	--

J9 Control Data		
From Driver 2		

J10 Not Used		
--------------	--	--

J11 Coil Drivers Bank B		
1	LL Flipper Power	Org/Blk
2	LL Flipper Hold	Org/Grn
3	Key	
4	Mystery Hole Kickout	Org/Vio
5	Drop Target 1 Drop	Org/Gry
6	Save Magnet	Org/Blu
7	Left Slingshot	Org/Wht
8	Drop Target 2 Drop	Org/Red
9	Not Used	

Driver 2

Multimorphic PD-16 (PCBA-0002-0002)



J1 Logic Power		
1	+5v	Red
2	GND	Blk

J2 Not Used		
-------------	--	--

J3 Coil Feed Bank A		
To RGB Power Splitter		

J4 Coil Feed Bank B		
1	+48v	Org
2	+48v	Blu
3	Key	

J5 Input Power Bank A		
1	+12v	Yel
2	Key	
3	GND	Blk

J6 Input Power Bank B		
1	+48v	Red
2	Key	
3	GND	Blk

J7 Coil Drivers Bank A	
To RGB Signal Splitter	

J8 Not Used	
-------------	--

J9 Control Data	
From MPU	

J10 Control Data	
To Driver 1	

J11 Coil Drivers Bank B		
1	Trough	Blu/Wht
2	Right Slingshot	Blu/Red
3	Key	
4	LR Flipper Power	Blu/Blk
5	Ball Launch	Blu/Vio
6	LR Flipper Hold	Blu/Grn
7	To K/S Option	Brn/Yel
8	To K/S Option	Brn/Blk
9	Not Used	

RGB Power Splitter

600-0291-00

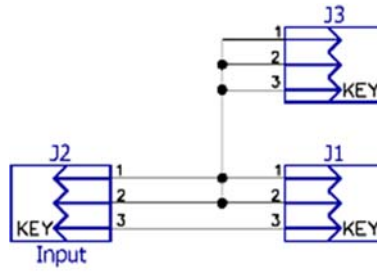

J1 Output		
1	Backbox Lamp Power	Yel
2	Not Used	
3	Key	

J2 Input	
	To Driver 2: J3

J3 Output		
1	Not Used	
2	Spkr RGB Power	Wht/Blk
3	Key	

RGB Signal Splitter

600-0290-00

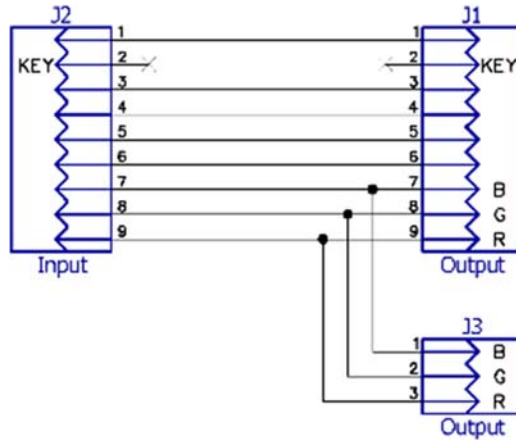

J1 Output	
1	? Brn/Grn
2	Key
3	? Brn/Red
4	Backbox Lamp Drive Blk
5	Not Used
6	Not Used
7	Not Used
8	Not Used
9	Not Used

J2 Input	
	To Driver 2: J7

J3 Output	
1	Spkr RGB Green Wht/Grn
2	Spkr RGB Blue Wht/Blu
3	Spkr RGB Red Wht/Red

K/S Option

600-0260-00

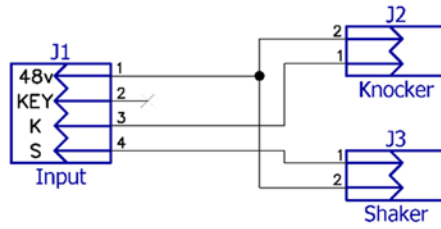

J1 Input		
1	+48v	Org
2	Key	
3	Knocker Drive	Brn/Yel
4	Shaker Drive	Brn/Blk

J2 Output: Knocker		
1	Coil Drive	
2	+48v	

J3 Output: Shaker		
1	Coil Drive	
2	+48v	

MPU

Multimorphic P3-ROC (PCBA-0008-0001)

