

GAME 1196
FO 680

Bally[®]

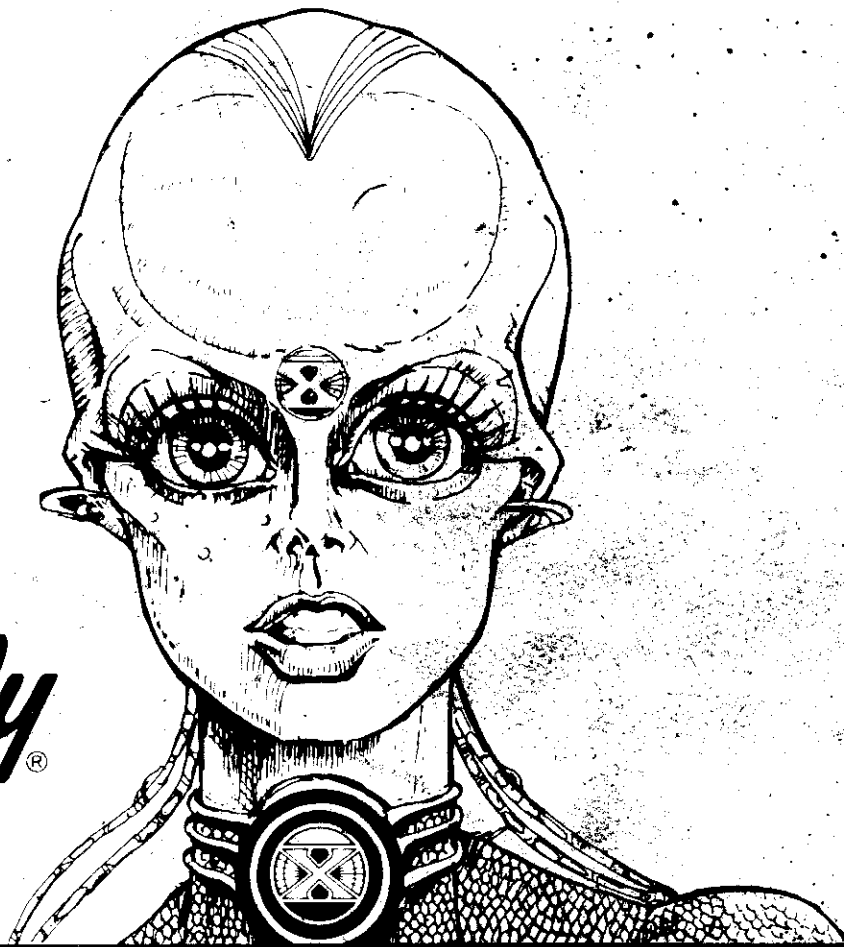

XENON

Bally

PINBALL DIVISION

© BALLY MFG. CORP. 1980
ALL RIGHTS RESERVED

90 O'Leary Drive, Bensenville, Illinois 60106, U.S.A.
Telephone: (312) 860-6400



Installation and General Game Operation Instructions

INDEX

	PAGE
I. INSTALLATION	1
II. GENERAL GAME OPERATION	2
III. BOOKKEEPING FUNCTIONS	3
IV. FEATURE OPERATION AND SCORING	4
V. GAME ADJUSTMENTS	5
A. PLAYFIELD ADJUSTMENTS	5
B. BACKBOX ADJUSTMENTS	5
CREDITS/COIN	5
MAXIMUM CREDITS	6
BALLS/GAME	6
MATCH FEATURE OPTION	6
CREDIT DISPLAY	6
HIGH SCORE FEATURE OPTION	6
HIGH SCORE TO DATE	6
GAME FEATURE OPTIONS	7
SOUND OPTION	7
C. FRONT DOOR GAME ADJUSTMENTS	
HIGH SCORE FEATURE	8
HIGH SCORE TO DATE FEATURE	8
VI. RECOMMENDED SCORE CARDS	11
VII. RECOMMENDED SETTINGS	12
VIII. ROUTINE MAINTENANCE ON LOCATION	13
IX. TROUBLE SHOOTING ON LOCATION	13
X. SERVICE/PARTS	19
XI. PARTS LIST	20-35

BLOCK DIAGRAM—ELECTRONIC PINBALL GAME

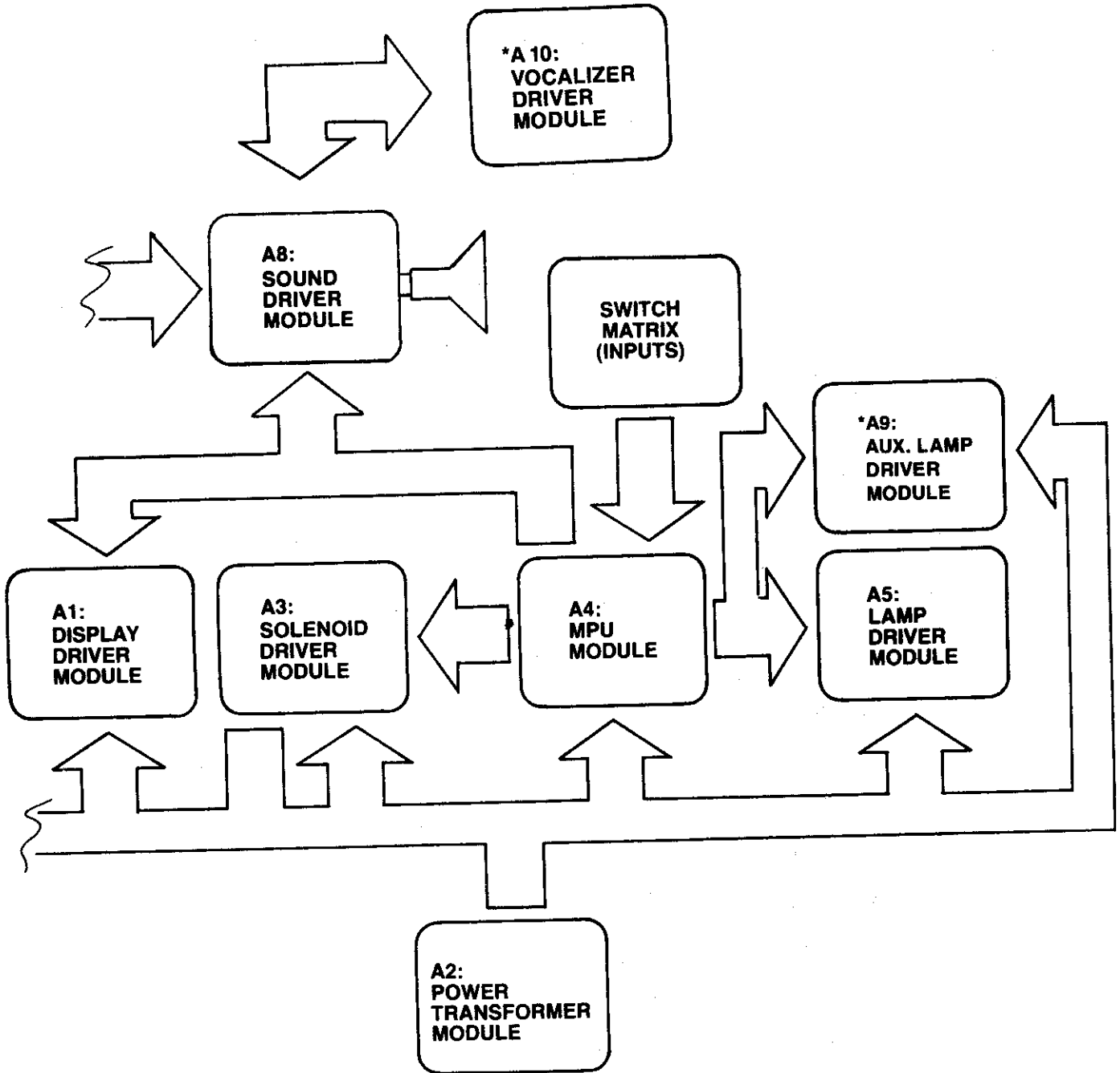

* USED ONLY ON REQUIRED GAMES.

I. INSTALLATION

Assemble the game as follows:

Bolt legs to cabinet. Bolt back box to cabinet. Use flat washers under bolt heads. Gently feed cable connectors and ground braid through cable port in back box. Screw ground braid to braid in back box. Carefully and fully insert connectors on printed circuit assemblies.

On all games there are certain items that should be checked after shipment. These are visual inspections which may avoid time consuming service work later. Minor troubles caused by abusive handling in shipment are unavoidable. Cable connectors may be loosened, switches (especially tilt switches) may go out of adjustment. Plumb bob tilt switch should always be adjusted after game is set on location and leg levelers are adjusted.

Visual inspections before plugging in line cord:

1. Check that all cable connectors are completely seated on printed circuit assemblies.
2. Check that cables are clear of all moving parts.
3. Check for any wires that may have become disconnected.
4. Check switches for loose solder or other foreign material that may have come loose in shipment and could cause shorting of contacts.
5. Check wires on coils for proper soldering. Cold solder connections may not show up in factory inspection, but vibration in shipment may break contact.
6. Check that fuses are firmly seated and making good contact.
7. Check the transformer for any foreign material shorting across wiring lugs.
8. Check wiring of transformer to correspond to location voltage. See figure 1.

Check adjustment of the three (normally open) tilt switches:

1. Panel tilt on bottom of playfield panel.
2. Plumb bob tilt on left side of cabinet near front door.
3. Ball tilt above plumb bob tilt. Insert the smaller ball (15/16" dia.) into the ball tilt assembly, and adjust the bracket so the ball will roll free to contact the switch blade, if front of cabinet is raised.

TRANSFORMER CONNECTION INSTRUCTIONS

**REFER TO POWER SUPPLY SCHEMATIC
IN GAME MANUAL FOR TABLE "A"**

115 VAC, 2-8, 3-6, 7-10
120 VAC, 2-8, 4-6, 7-11
220 VAC, 4-8, 7-9
240 VAC, 4-8, 7-11

PART OF POWER—TRANSFORMER MODULE A2, LOCATED IN LOWER CABINET

II. GENERAL GAME OPERATION

Place ball into playfield by outhole.

Coin game. Coin should be rejected. Plug in line cord. Move power ON-OFF master switch at bottom right front corner of cabinet to 'ON' position. The game will play a power-up tune to announce game-readiness. Drop targets are reset, scores are set to zero, alternating with the 'High Score to Date,' and the game is ready for play. Coin game. The game should accept the coin and post credits* for coins accepted (adjustable). Pressing the credit button on the door will cause the outhole kicker to serve the ball to the shooter alley. The 1st player-up lite is lit. A game-up tune* is played to announce play-readiness.

One player is posted each additional time the credit button is pressed (one to four can play). The credits are reduced by one each time the credit button is pressed until the credits are reduced to zero.

Shooting the ball initiates play.

The game awards all points earned by the player. If spinner is turning and scoring when the ball hits a target, the spinner and the target scores are awarded.

When the ball enters the outhole, the bonus score is added to the total score. The player-up and/or ball in play on the back box is advanced one position. The outhole kicker serves the ball to the shooter alley and play is resumed. This continues until each player has played the allowable number of balls per game (adjustable). At this time the 'Game Over' light is lit. A random Match* number appears and the 'Match' light is lit. If the number is the same as the last two digits in a player's score, a free game is awarded.

Extra balls won during the course of the game are played immediately after the player's regular ball enters the outhole. The player-up and/or ball in play on the back box are not advanced for extra ball play. Bonus score is added to the player's score before the game serves the extra ball for play.

Scoring over 10,000,000 gives "High Score to Date" award.

At the end of the game, a 'High Score to Date' is alternately flashed with all 4 player scores. If the 'High Score to Date' is beat, this feature* awards free games.

Tilting the game results in loss of a ball. The flippers, thumper-bumpers, etc., go 'dead'. Bonus points are not scored. The purpose of the tilt penalty is to discourage the player from jostling the machine in an attempt to prolong play. Game action becomes normal after the ball kicker assembly serves the ball to the shooter alley.

Slamming the machine results in loss of the game. All feature lights go out, the game goes 'dead,' and a time delay occurs. The purpose of the time delay is to discourage unnecessary abuse of the machine. After the delay, the 'Game Over' light lites and the power-up tune is played. The time delay occurs anytime one of the slam switches is made to contact. There are two factory installed slam switches, on the front door, and one on left side of cabinet. (Any number of slam switches could be installed by the operator, to meet his individual requirement.) The switch should be adjusted to have approximately 1/16" gap between the contacts. The weighted blade should be adjusted to attain the desired sensitivity. Decreasing the gap between contacts will make the switch more sensitive. Opening the gap will reduce sensitivity.

*Some tunes and features can be disabled by operator if so desired. See Back Box Adjustments.

NOTE: Scoring and feature units will differ from game to game.

III. BOOKKEEPING FUNCTIONS

The game is designed to help the operator perform certain accounting functions. The game can display the number of total plays and replays (free games). It can display the number of coins dropped down each coin chute. The bookkeeping functions are displayed on all player score displays simultaneously. An identification number, 05 to 15, appears on the Match/Ball in Play window as follows:

- 05— 00 to— 40 = Current Credits
- *06— 100000 to—99999 = Total Plays (Payed & Free Games)
- *07— 10000 to—99999 = Total Replays (Free Games)
- 08— 00 to—99999 = Game Percentage
- 09— 00 to—99999 = Total times 'High Score to Date' is beat
- *10— 10000 to—99999 = Coins Dropped thru Coin Chute #1
- *11— 10000 to—99999 = Coins Dropped thru Coin Chute #2**
- *12— 10000 to—99999 = Coins Dropped thru Coin Chute #3**
- *13— 00 to—99999 = Number of Specials awarded from Panel Specials Only
- *14— 00 to—99999 = Number of minutes of Game Play
- *15— 00 to—99999 = Number of Service Credits

The game displays the first bookkeeping entry if the Self-Test button (See Fig. III) on the inside of the front door is pressed ten times. Alternately push and release the Self-Test button at one second intervals. The number 05 appears in the 'Match/Ball in Play' window. Current credits appear on the player score displays. Each additional press of the button causes the next entry to be displayed.

After the data in each bookkeeping register is recorded, it can be set to zero simply by pressing switch button S33, located on A4, the MPU module in the back box (See Fig. III), or by pressing the Coin Chute #3 switch. Any or all registers can be cleared by alternating between the Self-Test button and the switch button S33 on the MPU module or Coin Chute #3 switch. The operator is given this option as a possible convenience and can elect to use or not use it as his needs direct.

Pressing the button 5 more times causes the game to play the power-up tune and light the Game Over light.

Service credits are designed to allow the serviceman to test the game under actual play conditions without disturbing the bookkeeping records that reside at identification numbers 06, 07, 10, 11 and 12.

To obtain Service Credits, push and release the Self-Test switch until identification number 05 appears in the 'Match/Ball in Play' window. Hold in the Credit button until the desired number of Service Credits (up to five) appears on the player score displays.

NOTE: If, upon accessing identification number 05, a number of credits greater than five is displayed, pressing the credit button has no effect.

Identification number 15 is reserved as a record of the number of Service Credits used.

*The 10,000 level is pre-set at the factory; can be set to zero, initially, if desired.

**If Coin Chute is not used in game, number displayed (if other than 00) on Player Score displays has no significance.

NOTE: If "Total Play" register is reset to zeroes then "Total Replays" register should also be reset to zeroes to maintain the game percentage value.

#1196 XENON

FEATURE OPERATION & SCORING

A. THE TUBE FEATURE

Each time a ball is shot into the TUBE, it falls into the Exit Chamber Saucer. Each time a ball falls into the Exit Chamber Saucer, it scores the lit Exit value bonus score, advances the Exit value and is kicked back onto the playing surface (see B below). The background sound and accompanying lighting effects increase in tempo in proportion to the scoring on the playfield; these are reset to the starting tempo each time the ball enters the Exit Chamber Saucer. This feature is held in memory from ball-to-ball on Switch #22.

- Fixed data switch #22 allows the TUBE bonus to be retained in memory:
 - #22 ON – Tube bonus recalled.
 - #22 OFF – Tube bonus reset.
- Fixed data switch #24 sets the top limit of the TUBE bonus.
 - #24 ON – 90,000 Exit value bonus limit
 - #24 OFF – 50,000 Exit value bonus limit
- Fixed data switch #21 controls the TUBE special lite once the exit value bonus limit is reached.
 - #21 ON – Special alternates once made
 - #21 OFF – Only ONE SPECIAL is possible, bonus resets after special is made.
- Fixed data switch #23 controls the advances of the TUBE bonus every time the ball falls into the Exit Chamber Saucer.
 - #23 ON – 2 advances on the Exit value bonus score.
 - #23 OFF – 1 advance on the Exit value bonus score.

B. TOP HOLE FEATURE

Each time the ball goes into the top hole the outhole XENON bonus may be advanced by one or two letters and one X symbol is awarded in the center of the playfield.

The first time (3) X symbols are completed, the tube entrance lite is lit to capture a ball in the Exit Chamber Saucer. The 2nd time the 3X symbol sequence is completed, the captured ball, along with the player's ball, is released. The next time the sequence is completed, during multi-ball play, the outlane special lites are lit. The next time a sequence is completed, a special is awarded (note: only during multi-ball play). If one ball enters the outhole before the sequence is completed the Tube is then requalified.

- Fixed data switches #15, 16 & 30 control the top saucer. (see next page).
- Fixed data switches #15 & 16 control the outhole XENON bonus advances awarded in the top saucer:

15 OFF	16 OFF – 5K	& No. Adv.
15 ON	16 OFF – 10K	& 1 Adv.
15 ON	16 ON – 10K	& 2 Adv.
- Fixed data switch #30 controls the Tube captured ball lites:
 - #30 ON – qualifying lites in memory.
 - #30 OFF – Not in memory.

C. DROP TARGET & TOP BUTTON FEATURE

Each time the ball rolls over a lit top button, 500 points are scored and the corresponding numbered drop target is knocked down. There are (2) sets of drop targets lites: One lite by each top numbered button and one lite behind each drop target. When any target is knocked down, both its corresponding lites go out.

When all (4) drop targets are knocked down, 10,000 pts. are scored and the lit feature is awarded. These features are reset ball-to-ball.

- Fixed data switch #6 starts the drop targets with the 2X lite ON.
- Fixed data switch #8 allows only 1 special per ball on the Drop Targets.
- Fixed data switch #7 advances the Tube bonus once every time the (4) drop targets are knocked down.
 - 1st time down 2X (if #6 ON) also turns on return lanes.
 - 2nd time down 4X
 - 3rd time down 25K
 - 4th time down X-Ball
 - 5th and each additional time SPECIAL.
- If #8 OFF only one special per ball.
- Fixed data switch #14 alternates the outlanes and return lanes.
 - #14 ON –Both ON
 - #14 OFF –Alternates

D. XENON BONUS SCORE FEATURE

A bonus of 2000 to 58,000 may be scored. The game starts with a bonus of 2000. The bonus score may be advanced each time the ball goes into the top center saucer.

The bonus score also advances one step each time a lit left side advance bonus target is lit, and each time any drop target is knocked down when the drop target adv. bonus lite is lit.

When a bonus score of 20,000 or higher is achieved the 20,000 and 40,000 SUPER BONUS LITES remain in memory. A special is awarded when the XENON bonus sequence is made when the Special lite is lit (3rd and additional sequences).

This feature is in memory. A tilt nullifies the bonus score.

E. THUMPER—BUMPER FEATURE

Each thumper bumper scores 100 points.

F. SPINNER FEATURE

The spinner scores 10 points/1000 when lit. The spinner is lit on multi-ball play. This feature is reset ball-to-ball.

G. GAME OVER VOCAL FEATURE

Fixed data switch #29 ON –Vocal repeats every 2 minutes.
OFF—No vocal attract.

H. SPECIAL REPLAY/X-BALL/NOVELTY MODES

Self test positions 16 and 17 give the operator flexibility to award a replay, extra ball or score (Novelty) when a special is scored. A combination of X/Ball, Novelty, Novelty can be obtained through the following chart:

Self test position 16	Set to "03"	Set to "02"	Set to "01"
Playfield X-Balls and Specials	Award	Award	Award
Top saucer 3X lites			
multi-ball special (not shown)	Replay	X-ball*	50,000
Xenon Special	Replay	X-ball*	50,000
Side saucer Special	Replay	X-ball*	50,000
Left or right out Special	Replay	X-ball*	50,000
Drop target special	Replay	X-Ball*	50,000
Drop target X-ball	X-ball	X-ball**	25,000
Self-test position 17	Set to "03"	Set to "02"	Set to "01"
	Award	Award	Award
Scoring Thresholds	Replay	X-ball**	No Award

(*) 50,000 if same player shoot again is lit.

(**) 25,000 if same player shoot again is lit.

V. GAME ADJUSTMENTS

A. Playfield Panel Post Adjustments:

Posts that control left and right outlane opening on panel can be removed to make access to outlanes easier or harder for ball to enter. See Figure II.

Easier entry will decrease playing time and scoring (conservative).

Harder entry will increase playing time and scoring (liberal).

B. Back Box Game Adjustments:

Each game has thirty-two switches located on A4, the MPU module, located in the back box, that allow play to be customized to the location. See Figure III. Credits per coin, maximum credits, credit display, balls per game, match feature, high game feature, special award and melody are selectable by means of the switches. The switches are contained in four-sixteen lead packages numbered S1-8, S9-16, S17-24, and S25-32 for easy identification. The "ON" toggle position is marked on the assembly. **Turn off power before making adjustments.**

Credits/Coin Adjustments:

The credits per coin are selectable by means of S17-S20 for coin chute #2 (Center). The switch settings and resultant credits/coin are as follows:

S20	S19	S18	S17	Credits/Coin	S20	S19	S18	S17	Credits/Coin
OFF	OFF	OFF	OFF	Same as Coin Chute #1 Settings	ON	OFF	OFF	OFF	8/1 Coin
OFF	OFF	OFF	ON	1/1 Coin	ON	OFF	OFF	ON	9/1 Coin
OFF	OFF	ON	OFF	2/1 Coin	ON	OFF	ON	OFF	10/1 Coin
OFF	OFF	ON	ON	3/1 Coin	ON	OFF	ON	ON	11/1 Coin
OFF	ON	OFF	OFF	4/1 Coin	ON	ON	OFF	OFF	12/1 Coin
OFF	ON	OFF	ON	5/1 Coin	ON	ON	OFF	ON	13/1 Coin
OFF	ON	ON	OFF	6/1 Coin	ON	ON	ON	OFF	14/1 Coin
OFF	ON	ON	ON	7/1 Coin	ON	ON	ON	ON	15/1 Coin

The credits given are selectable by means of switches 1-5 incl., for coin chute #1 and switches 9-13 incl., for coin chute #3. Thirty-one different credit ratios are available for each coin chute. The switch settings and resultant credits/coin are listed below.

CREDITS/COIN ADJUSTMENTS

COIN CHUTE	SWITCHES					CREDITS	CREDITS	CREDITS	CREDITS	TOTAL CREDITS/COINS
	5	4	3	2	1					
#1 (HINGE SIDE)	5	4	3	2	1					
OR #3	13	12	11	10	9					
(RIGHT SIDE)										
	OFF	OFF	OFF	OFF	OFF	1/1 Coin				
	OFF	OFF	OFF	OFF	ON	2/1 Coin				
	OFF	OFF	OFF	ON	OFF	3/1 Coin				
	OFF	OFF	OFF	ON	ON	4/1 Coin				
	OFF	OFF	ON	OFF	OFF	5/1 Coin				
	OFF	OFF	ON	OFF	ON	6/1 Coin				
	OFF	OFF	ON	ON	OFF	7/1 Coin				
	OFF	OFF	ON	ON	ON	8/1 Coin				
	OFF	ON	OFF	OFF	OFF	9/1 Coin				
	OFF	ON	OFF	OFF	ON	12/1 Coin				
	OFF	ON	OFF	ON	OFF	14/1 Coin				
	OFF	ON	OFF	ON	ON	1/2 Coins*				
	OFF	ON	ON	OFF	OFF	2/2 Coins*				
	OFF	ON	ON	OFF	ON	3/2 Coins*				
	OFF	ON	ON	ON	OFF	4/2 Coins*				
	OFF	ON	ON	ON	ON	5/2 Coins*				
	ON	OFF	OFF	OFF	OFF	6/2 Coins*				
	ON	OFF	OFF	OFF	ON	7/2 Coins*				
	ON	OFF	OFF	ON	OFF	8/2 Coins*				
	ON	OFF	OFF	ON	ON	9/2 Coins*				
	ON	OFF	ON	OFF	OFF	12/2 Coins*				
	ON	OFF	ON	OFF	ON	14/2 Coins*				
	ON	OFF	ON	ON	OFF	1/1st Coin	2/2nd Coin			3/2
	ON	OFF	ON	ON	ON	0/1st Coin*	1/2nd Coin	1/3rd Coin	1/4th Coin	3/4
	ON	ON	OFF	OFF	OFF	0/1st Coin*	1/2nd Coin	0/3rd Coin**	2/4th Coin	3/4
	ON	ON	OFF	OFF	ON	1/1st Coin	1/2nd Coin	1/3rd Coin	2/4th Coin	5/4
	ON	ON	OFF	ON	OFF	1/1st Coin	2/2nd Coin	1/3rd Coin	3/4th Coin	7/4
	ON	ON	OFF	ON	ON	1/1st Coin	2/2nd Coin	2/3rd Coin	2/4th Coin	7/4
	ON	ON	ON	OFF	OFF	1/1 Coin				
	ON	ON	ON	OFF	ON	1/1 Coin				
	ON	ON	ON	ON	OFF	1/1 Coin				
	ON	ON	ON	ON	ON	1/1 Coin				

*No Credits until second coin is dropped.

**No Credits until 4th coin is dropped.

MAXIMUM CREDITS:

The maximum credits accepted by the machine limits the number of games that can be accumulated by coining, by winning replays or both. The maximum number of credits is selectable by means of switches 25 and 26. Four credit limits are available. Switch settings are listed below.

MAXIMUM CREDITS	SWITCHES	
	26	25
10	OFF	OFF
15	OFF	ON
25	ON	OFF
40	ON	ON

BALLS PER GAME:	# BALLS /GAME	SWITCHES	32	31
	5		OFF	ON
	4		ON	OFF
	3		OFF	OFF
	2		ON	ON

MATCH FEATURE:

When the Match Feature is ON, a random number appears on the Match/Ball in Play window and the word Match is illuminated. If the number matches the tens digit in a player's score, a free game is awarded. The Match Feature creates an incentive to play.

CREDIT DISPLAY:	MATCH	SWITCH 28
	ON	ON
	OFF	OFF
CREDIT DISPLAY:	CREDITS DISPLAYED	SWITCH 27
	YES	ON
	NO	OFF

HIGH SCORE FEATURE:

The game is designed to award an Extra Ball or Free Game at each of the two or three score levels. See Front Door Game Adjustments.

AWARD	SELF TEST POSITION 16	SELF TEST POSITION 17
REPLAY	SET TO "03"	SET TO "03"
EXTRA BALL	SET TO "02"	SET TO "02"
NO AWARD	SET TO "01"	SET TO "01"

For combinations of replay/X-ball/Novelty Modes see page 4A "K. Special Replay/X-ball/Novelty Modes"

HIGH SCORE TO DATE OR OVER 10,000,000 SCORE FEATURE:

The game is designed to award free games as an option if high score to date is beat or player exceeds 10,000,000 points. Each time this happens, the winning score becomes the new high score to beat. This score is displayed on all 4 player score displays at the end of each game as an incentive to play. Recommended setting is underlined.

HIGH SCORE TO DATE FEATURE	SELF TEST POSITION 19
No Award	SET TO "00"
One Credit	SET TO "01"
Two Credits	SET TO "02"
<u>Three Credits</u>	SET TO "03"

State and local laws may regulate the use of the above features, and they have been designed to allow for appropriate adjustment in order to conform to such requirements.

#1196 XENON

SOUND OPTION

The game is designed to make several tones and noises to announce power-up, game-up, etc. The tones are intended to attract attention to the game and increase game usage. The tones are controlled by pressing self test button until the #18 shows on the match/ball in play display. Now pulse replay button to desired sound setting.

Setting "00"

Most switches associated chimes without feature background.

Setting "01"

Playfield switches associated chimes with background.

Setting "02"

Most scoring will have noise effect without background.

Setting "03"

Most all scoring will have a noise effect with background.

GAME FEATURE OPTIONS:

Drop target 2X lite adjustment:

Liberal	SW. 6 ON	2X is on at start of game.
Conservative	SW. 6 OFF	2X is not on at start of game.

Drop target tube exit value adjustment:

Liberal	SW. 7 ON	Making 4 drop targets, exit value steps up 1.
Conservative	SW. 7 OFF	Making 4 drop targets, exit value does not step.

Drop target special lite adjustment:

Liberal	SW. 8 ON	Making 4 drop targets, lite stays lit.
Conservative	SW. 8 OFF	Making 4 drop targets, lite steps to 25,000.

Outlanes & Flipper feed lanes arrow lite adjustment:

Liberal	SW. 14 ON	Both lites come on for outlane or flip feed.
Conservative	SW. 14 OFF	1 lite comes on for either one then alternates.

Top saucer scoring and Xenon lite advances adjustment:

Liberal	SW. 15, 16 ON	Scores 10,000 and 2 lite advances.
Medium	SW. 15 ON, 16 OFF	Scores 10,000 and 1 lite advance.
Conservative	SW. 15, 16 OFF	Scores 5,000 and no lite advances.

Side saucer mota special lite adjustment:

Liberal	SW. 21 ON	Special will alternate.
Conservative	SW. 21 OFF	Special resets with the score.

Side saucer mota score lites adjustment:

Liberal	SW. 22 ON	Any lite lit will come on for next ball.
Conservative	SW. 22 OFF	Any lite will reset to 5,000.

Side saucer mota lite advance adjustment:

Liberal	SW. 23 ON	Mota lites advance 2 times.
Conservative	SW. 23 OFF	Mota lites advance 1 at a time.

Side saucer mota 50,000, 90,000 lite adjustment:

Liberal	SW. 23 ON	Mota lites advance 2 times.
Conservative	SW. 23 OFF	Mota lites advance 1 at a time.

Side saucer mota 50,000, 90,000 lite adjustment:

Liberal	SW. 24 ON	Lites step to 90,000.
Conservative	SW. 24 OFF	Lites step to 50,000 only.

Game over attract adjustment:

Liberal	SW. 29 ON	Voice says "Try Me Again."
Conservative	SW. 29 OFF	No Voice.

Top saucer first 2X lites adjustment:

Liberal	SW. 30 ON	Any lites on will come on for next ball, if the tube entrance light is not flashing.
Conservative	SW. 30 OFF	Any lites on will not come on for next ball.

C. FRONT DOOR GAME ADJUSTMENTS

High Score Feature Adjustments:

The game is designed to award an extra ball (option) or a free game at each of three score levels. The recommended levels are on the score card in the game.

Any level from 10,000 to 9,999,000 can be set, as desired. It is also possible to reset or turn off (00) any or all of the levels, if desired.

1. Push and release Self-Test button (See Figure III) at one second intervals approximately six times or until identification number 01 appears on the 'Match/Ball in Play' display.
2. The number on the Player Score Displays is the score level.* It can be increased, if desired, by holding the credit button in. To decrease the score level, hold the credit button in and depress and release the Self-Test button. Release the credit button when the desired number appears. Note that the level changes 10,000 points at a time. If the number '00' is left on the displays, the high score feature is eliminated for that level.
3. Repeat steps 1 and 2 for the second and third score levels. The identification numbers '02' and '03' on the Match/Ball in Play display are for the second and third levels, respectively.

High Score to Date and 10,000,000 Feature:

The game is designed to award free games when 'High Score to Date' is beat, or if the player exceeds 10,000,000 points.

It is recommended that the level, which will build with play, be periodically reset to the factory recommended level to encourage game play. The adjustment procedure is the same as for the High Score Feature Adjustment, Steps 1 and 2. Continue pushing the Self-Test button until the identification number '04' appears on the 'Match/Ball in Play' display and then do Step 2.

Any level from '00' to 9,990,000 can be set as described. It is to be noted that '00' does NOT turn off the feature, as it does on High Score feature. The feature is turned off by self test position 19 as discussed under 'Back Box Game Adjustments.'

SELF TEST SETUP FOR 16-19:

To set up positions 16-19 push and release self test button till 16 shows on match/ball in play. Now pulse replay button for recommended setup from "00" thru "03." Repeat for positions 17, 18 or 19.

SOUND

In addition to individual volume controls for speech and other game sounds on the Sounds Plus Board. There is also a Master Volume Control located on the front door. (refer to page 10)

Please note that these module volume controls should be adjusted prior to setting the control on the front door.

*Can be quickly set to '00' by pressing S33 on the MPU assembly in the back box or Coin Chute switch #3. (See Figure III).

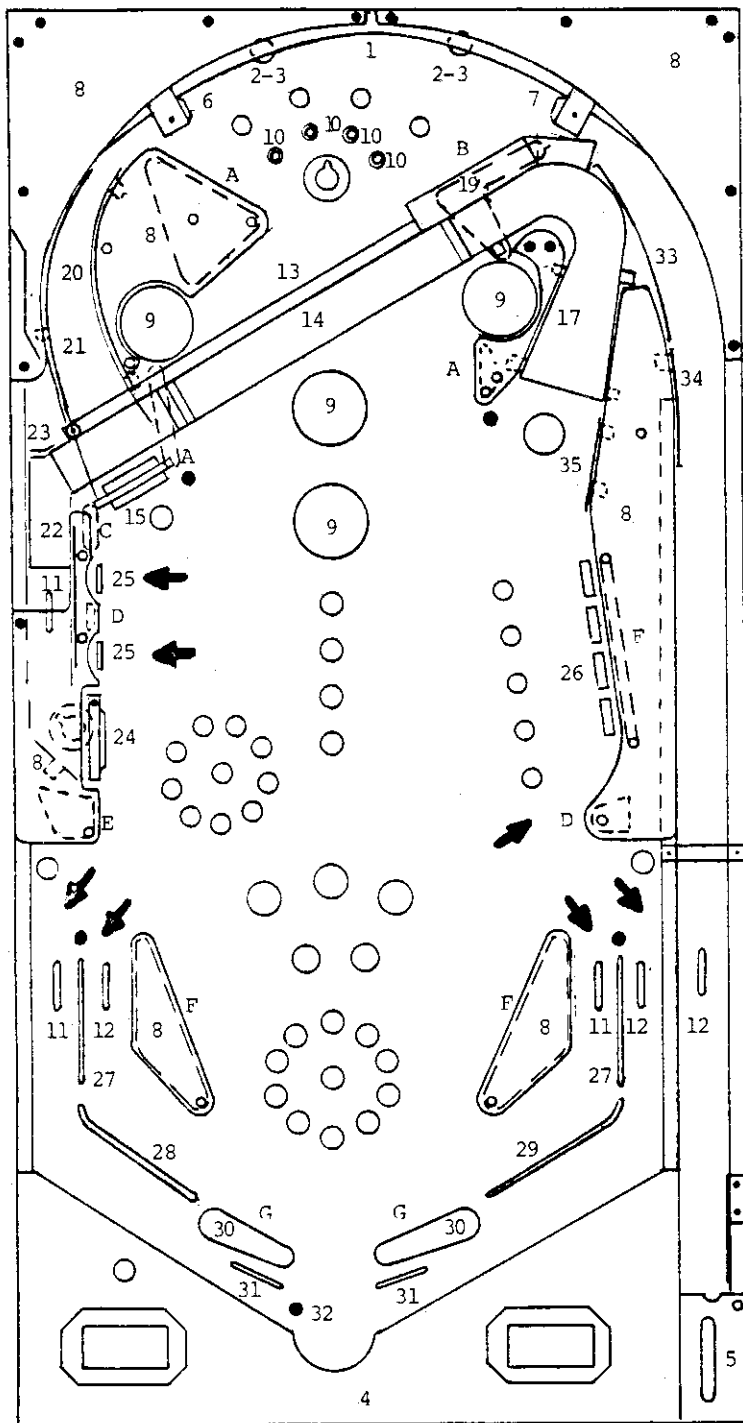

#1196 XENON

RUBBER PARTS

A.	R-521-2	1½" DIA.	(3)
B.	R-521-6	3½" DIA.	
C.	R-521-1	1" DIA.	
D.	R-521	¾" DIA.	(2)
E.	R-521-3	2" DIA.	
F.	R-521-4	2½" DIA.	(4)
G.	R-406-3	FLIPPER	(2)

PANEL TOP PARTS

1.	Arch Rail	M-1774	
2.	Rail Post	C-907	(2)
3.	Rail Post Cap	C-908	(2)
4.	Bottom Arch	P-5871-81	
5.	Shooter Gauge	P-6359-46	
6.	Ball Gate (Left)	A-1475-12	
7.	Ball Gate (Right)	A-1475-13	
8.	Panel Plastics	M-1330-172	
9.	Thumper Bumper Cap	A-3713-66	(4)
10.	Rollover Button	C-587-6	
11.	Rollover Wire Assy.	AS-2806	(3)
12.	Rollover Wire Assy.	AS-2806-1	(4)
13.	Xenon Light Strip	AS-2518-60	
14.	Ball Tube	M-1922	
15.	Spinner Gate Assy.	AS-2250-78	
17.	Ball Ramp Assy.	A-3066-51	
19.	Micro Sw. & Wire	AS-2744-14	
20.	Ball Guide Assy.	A-3032-57	
21.	Ball Guide Assy.	A-3032-58	
22.	Ball Down Ramp	P-6244-107	
23.	Ball Guide Stop Assy.	A-2898-37	
24.	Ball Gate & Wire Assy.	AS-2250-24	
25.	Target Assy. (Yellow)	AS-2911-21	(2)
26.	Drop Target Assy.	AS-3038-2	
27.	Ball Guide Wire	M-121-18	(2)
28.	Ball Guide Wire	M-121-43	
29.	Ball Guide Wire	M-121-44	
30.	Flipper & Shaft Assy.	AS-2214-21	(2)
31.	Buffer Wire	M-121-53	(2)
32.	Minipost & Rubber Assy.	AS-2836-1	(5)
33.	Ball Guide Wire	M-121-108	
34.	Ball Guide Assy.	A-3032-59	
35.	Ball Guide Assy.	A-3032-60	

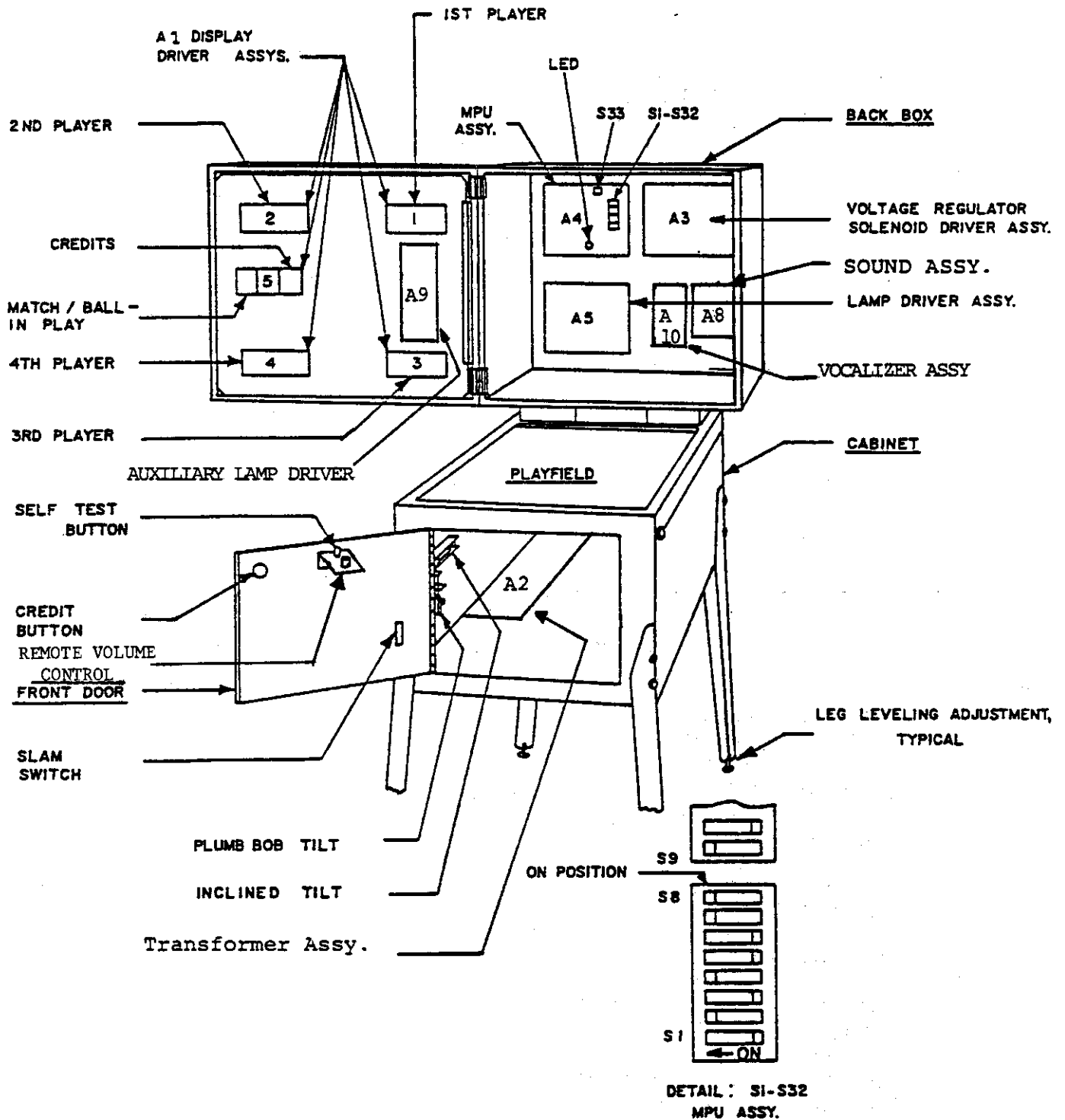

FIGURE III. ELECTRONIC PIN BALL MACHINE

RECOMMENDED

Instruction, Score Cards and High Score Feature Settings
to be used on **XENON 1196**

3-BALL

REPLAYS

Instruction Card	M-1508-93-E
Score Card	M-1508-93-B
1 Replay at 500,000	
1 Replay at 1,000,000	

5-BALL

REPLAYS

Instruction Card	M-1508-93-E
Score Card	M-1508-93-A
1 Replay at 600,000	
1 Replay at 1,100,000	

EXTRA BALL

Instruction Card	M-1508-93-F
Score Card	M-1508-93-A W/NN-1
1 Extra Ball at 600,000	
1 Extra Ball at 900,000	
1 Extra Ball at 1,200,000	

ADDITIONAL CARDS

REPLAYS

M-1508-H-1	400,000	950,000	
M-1508-I-1	450,000	1,000,000	
M-1508-J-1	500,000	1,000,000	
M-1508-K-1	500,000	1,100,000	
M-1508-L-1	550,000	1,100,000	
M-1508-M-1	600,000	1,100,000	
M-1508-N-1	650,000	1,200,000	
M-1508-O-1	700,000	1,200,000	
M-1508-P-1	800,000	1,300,000	
M-1508-Q-1	800,000	1,400,000	
M-1508-R-1	900,000	1,400,000	
M-1508-S-1	900,000	1,500,000	
M-1508-T-1	1,000,000	1,500,000	
M-1508-U-1	1,100,000	1,600,000	
M-1508-V-1	1,200,000	1,600,000	
M-1508-FF-1	500,000	800,000	1,100,000
M-1508-GG-1	600,000	1,100,000	1,300,000
M-1508-HH-1	700,000	1,400,000	1,600,000
M-1508-II-1	800,000	1,300,000	1,600,000
M-1508-JJ-1	900,000	1,400,000	1,600,000
M-1508-KK-1	1,000,000	1,500,000	1,800,000

EXTRA BALL

M-1508-NN-1	600,000	900,000	1,200,000
M-1508-OO-1	800,000	1,100,000	1,400,000
M-1508-PP-1	900,000	1,200,000	1,400,000
M-1508-QQ-1	1,000,000	1,400,000	1,800,000

Instruction Card, Novelty
M-1508-93-G

BLANKS (3)

High game to date recommended levels;
(reset periodically)
3 BALL 1,200,000
5 BALL 1,300,000

#1196 XENON

RECOMMENDED SETTINGS

RECOMMENDED REPLAY GAME SETTINGS FOR:

	3-BALL	5-BALL
DROP TARGET 2X LITE	SW. 6 ON	OFF
DROP TARGET, SIDE SAUCER LITE ADVANCE	SW. 7 OFF	OFF
DROP TARGET 25K AND SPECIAL LITE	SW. 8 OFF	OFF
OUTLANE AND FLIP FEED ARROW LITES	SW. 14 ON	OFF
TOP SAUCER SCORING & XENON LITE ADVANCE	SW. 15 ON	ON
TOP SAUCER SCORING & XENON LITE ADVANCE	SW. 16 ON	OFF
SIDE SAUCER SPECIAL LITE	SW. 21 ON	OFF
SIDE SAUCER SCORE LITES RECALL	SW. 22 ON	ON
SIDE SAUCER LITE ADVANCE	SW. 23 ON	OFF
SIDE SAUCER 50K or 90K	SW. 24 ON	ON
GAME OVER VOICE	SW. 29 ON	ON
TOP SAUCER 2 X LITES RECALL	SW. 30 ON	OFF
BALLS PER GAME	SW. 31 OFF	ON
BALLS PER GAME	SW. 32 OFF	OFF

REPLAY

Instruction Card
Score Card
Major Mode

Match
High Score to Date

3-BALL

M-1508-93-E
M-1508-93-B
Self Test Position 16, 17
Set to "03"
SW. 28 ON
Self Test Position 19
Set to "03"

5-BALL

M-1508-93-E
M-1508-93-A
Self Test Position 16, 17
Set to "03"
SW. 28 ON
Self Test Position 19
Set to "03"

X-BALL

Instruction Card
Score Card
Major Mode

Match
High Score to Date

M-1508-93-F
M-1508-93-A W/NN-1
Self Test Position 16, 17
Set to "02"
SW. 28 OFF
Self Test Position 19
Set to "00"

NOVELTY

Instruction Card
Major Mode

Match
High Score to Date

M-1508-93-G
Self Test Position 16, 17
Set to "01"
SW. 28 OFF
Self Test Position 19
Set to "00"

M-1508-93-G
Self Test Position 16, 17
Set to "01"
SW. 28 OFF
Self Test Position 19
Set to "00"

ADDITIONAL CARDS FOR PAGE 11

REPLAYS

M-1508-UU	480,000	720,000	M-1508-EEE	380,000	670,000	820,000
M-1508-VV	500,000	740,000	M-1508-FFF	400,000	690,000	840,000
M-1508-WW	520,000	760,000	M-1508-GGG	420,000	710,000	860,000
M-1508-XX	540,000	780,000	M-1508-HHH	440,000	730,000	880,000
M-1508-YY	560,000	800,000	M-1508-III	460,000	750,000	900,000
M-1508-ZZ	580,000	820,000	M-1508-JJJ	480,000	770,000	920,000
M-1508-AAA	600,000	840,000	M-1508-KKK	500,000	790,000	940,000
M-1508-BBB	620,000	860,000	M-1508-LLL	520,000	810,000	960,000
M-1508-CCC	640,000	880,000	M-1508-MMM	540,000	830,000	980,000
M-1508-DDD	660,000	900,000	M-1508-NNN	560,000	850,000	990,000

VIII. ROUTINE MAINTENANCE ON LOCATION:

Self-Test routines are written into the game design. They are particularly useful for routine maintenance. The tests are described below. The first test is automatic and occurs on power-up. This test causes the MPU module A4 to examine itself for failures. Seven flashes of an LED indicates proper operation. The second series of self-diagnostic tests causes the MPU to 'exercise' each of the other modules in such a way as to make their faults, if any, obvious. See Figure III and Page ii.

It is recommended that these tests be used several times a week to check out the games before play. If faults are discovered, they may be corrected on location if the operator has a stock of replacement modules. See "Trouble Shooting on Location."

MPU Module Self-Test:

At power on, the LED on the MPU module flashes once. (Flicker-Flash). After a pause, it flashes six more times and goes out. A power-up tune is played to announce game readiness. This indicates proper MPU operating condition and successful completion of the power-up test.

Game Self-Diagnostic Tests:

1. Pressing the Self-Test button inside the door initiates the Self-Test routine. See Figures III and IV. All switched lamps flash off and on continuously.
2. Pressing the Self-Test button again causes each digit on each display to cycle from 0 thru 9, and repeat continuously.
3. Pressing the Self-Test button again causes each solenoid to be energized, one at a time, in a continuous sequence. Hold both flipper buttons 'in' during this test. The number appearing on the Player Score displays is the same as the number assigned to the solenoid. The sound of a solenoid pulling-in as a number appears indicates proper operation. The absence of sound is improper. If sound is absent, see Page 17 for help in Solenoid identification.
4. Pressing Self-Test button again causes the sound module to play the "Game Over" tune repeatedly.
5. Pressing the Self-Test button again causes the MPU to search each switch assembly for stuck contacts. If any are found, the number of the first set encountered is flashed on the Player Score displays. The number remains until the fault is cleared. See Page 17 for help in Stuck Switch identification. Other numbers may follow if more stuck contacts are present. If there are no stuck switches, the Match/Ball in Play display flashes '0'.
6. Pressing the Self-Test button 20 more times causes the MPU to step thru the threshold and bookkeeping functions described previously and finally to repeat the power-up test. For more rapid exit to power-up, turn the game off, then on. The game is now ready to play.

After successful completion of the Self Diagnostic Test procedure, set the game up for play. Exercise each rollover, thumper-bumper, slingshot, etc., by hand until each switch assembly on the playfield has been checked for proper operation. If actuating a switch assembly results in intermittent or no response, clean contacts by gently closing them on a clean business card or piece of paper and wiping until they wipe clean. Regap, if necessary, to 1/16". **Do not burnish or file Gold Plated Switch Contacts.**

IX. TROUBLESHOOTING ON LOCATION

The game is designed to make troubleshooting easy. Several simple procedures are given herein that cover the greatest percentage of game failures. They are written for an operator on location and require module replacement. (See Figure III) Symptoms and the action to be taken are given for each type of problem.

If the problem is more complicated and is not solved by following this procedure, more detailed procedures are available from Bally. See the Parts List for ordering information.

FIGURE IV SELF DIAGNOSTIC TEST

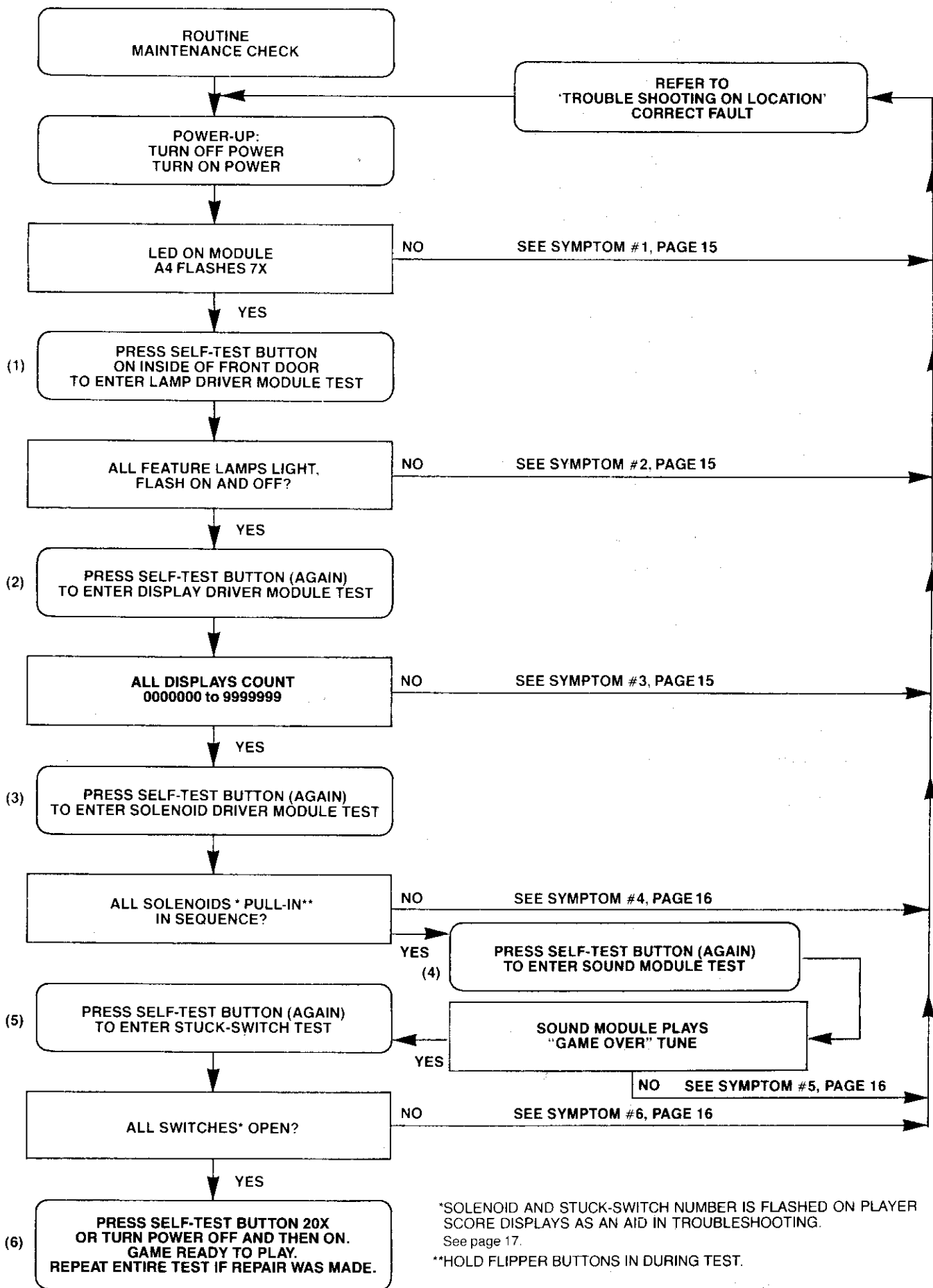

*SOLENOID AND STUCK-SWITCH NUMBER IS FLASHED ON PLAYER SCORE DISPLAYS AS AN AID IN TROUBLESHOOTING.

See page 17.

**HOLD FLIPPER BUTTONS IN DURING TEST.

- 1A) SYMPTOM:** Game does not play power-up tune when power is turned on. General illumination is present.
- ACTION:**
- A)** Turn power OFF. Open back box. Locate light emitting diode (LED) on MPU module A4.
 - B)** Turn Power ON. LED must flash 7X to indicate that module A4 is good. Correct flash sequence is flicker/flash-pause-and then six more flashes and LED goes out.
 - C.** If LED does not come on, or does not flash, or flashes, but less than 7X, turn off power. Replace MPU module A4.
- CAUTION:** **Replacement MPU Module must have same Part Number or incorrect operation will result! See Parts List for MPU Module Part Number.**
- Turn power ON.
- D)** If game is correct, it is now ready for play. If game is not correct, refer to Module Replacement procedure. (See Parts List.)
- 2A) SYMPTOM:** Not all feature lamps light during game play.
- ACTION:**
- A)** With power ON, open front door. Press button (Self-Test switch) once. If the game is correct, **all** feature lamps flash ON and OFF.
 - B)** Carefully raise playfield or open back box to gain access to lamps.
 - C)** Replace bulbs that do not flash.
 - D)** If game is correct, it is now ready for play.
 - E)** If game is not correct, turn power OFF. Replace Lamp Driver Module A5. Turn power ON and repeat A.
 - F)** If game is correct, it is now ready for play.*
 - G)** If game is not correct, turn power OFF. Replace MPU module A4. See CAUTION, 1C. Turn power ON and repeat A.
 - H)** If game is correct, it is now ready for play.* If game is not correct, refer to Module Replacement procedure. (See Parts List.)
- 2B) SYMPTOM:** One or some switched lamps always ON.
- ACTION:** Repeat 2AA, AB, AE, and AF and, if necessary AG & AH.
- 3A) SYMPTOM:** Display digits improper on **one** or **several**, but less than all Display Driver module(s), A1. Improper: One or several segments always OFF, digits mottled or several segments or digit(s) always ON.
- ACTION:**
- A)** With power ON, open front door. Press button (Self-Test switch) twice. If the game is correct, each digit on each Display Driver Module A1 (5 used/game) displays the count 1-9 and 0 continuously in all 6 digit positions. Note defective Display Driver modules.
 - B)** Turn power OFF.
- CAUTION: High Voltage is supplied to the Display Driver Modules, A1, from the Solenoid Driver/Voltage Regulator Module A3. Wait 30 seconds for High Voltage to Bleed Off.**
- C)** Replace Display Driver module(s) A1. Turn power ON. Repeat A.
 - D)** If game is correct, it is now ready to play.* If game is not correct, refer to Module Replacement procedure. (See Parts List.)
- 3B) SYMPTOM:** **All** displays improper (all five display Driver modules). Improper: Digit(s) always on or off/segment(s) always on or off, all displays.
- ACTION:**
- A)** Repeat 3AA, and AB.
 - B)** Replace MPU module A4. See CAUTION NOTE, 1C. Turn power ON. Repeat A.

- C) If game is correct, it is now ready to play.* If game is not correct, refer to Module Replacement procedure. (See Parts List.)
- 3C) **SYMPTOM:** One or several displays always off.
ACTION: A) Do 3AA, AB, AC, and AD.
 B) Repeat 3BB and BC, if necessary.
- 4A) **SYMPTOM:** Solenoid(s) do(es) not pull-in during course of game.
ACTION: A) With power ON, open front door. Press button (Self-Test switch) three times.
 B) If game was correct, each solenoid would be energized. A number is flashed on the Player Score displays as each solenoid is pulsed. Note any numbers that do not have the sound of a solenoid associated. See Solenoid Identification Table, Page 17 and Figure V.
 C) Carefully lift the playfield (or open the back box) to gain access to the solenoid. Turn power OFF. Inspect the solenoid.
 D) If a lead is broken off, repair. Repeat A & B. If game is correct, it is now ready for play.* If solenoid wiring was correct, turn power OFF.
 E) Replace Solenoid Driver/Voltage Regulator module A3. See CAUTION NOTE 3AB.
 F) Repeat AA & AB. If game is correct, it is now ready to play.* If game is not correct, turn power OFF.
 G) Replace Sound Module A8.
 H) Repeat AA and AB if game is correct. It is now ready to play. If game is not correct, turn power OFF.*
 I) Replace MPU module A4. See CAUTION NOTE, 1C.
 J) Repeat A & B. If game is correct, it is now ready to play.* If game is not correct, refer to Module Replacement Procedure. (See Parts List.)
- 4B) **SYMPTOM:** Solenoid(s) always energized—Note: if impulse solenoids (ball ejects, slingshots, thumper-bumpers, etc.) are energized continuously, they are subject to damage. Limit troubleshooting to one minute with power ON, followed by **five minutes with power OFF**. Repeat as necessary. Replace damaged solenoids.
ACTION: Do 4AA, AB, AE, AF, AG, AH and if necessary, AI and AJ.
- 5) **SYMPTOM:** No Sound.
ACTION: A) With Power ON, open front door, press Self-Test switch four times.
 B) Turn volume control clockwise to Max.
 C) If correct, sound will be heard. If incorrect, try seating speaker lead connector (J2) and input connector (J1).
 D) If correct, sound will be heard. If incorrect, refer to Module Replacement procedure.*
- 6) **SYMPTOM:** Feature (Drop Targets, etc.) does not score.
ACTION: A) With power ON, open front door. Press button (Self-Test switch) five times.
 B) If the game is correct, Match/Ball in Play display would flash '0'. If a number appears on the Player Score displays, see Switch Assembly Identification Table, Page 17 and Figure V.
 C) Carefully lift the playfield. Locate the switch assembly identified from the number. Visually inspect the switch assembly. If the contacts are 'stuck', regap them to 1/16". See section under ADJUSTMENTS. Repeat A & B. If the game is correct, it is now ready to play.* If game is not correct, turn the power OFF.
 D) Replace MPU module A4. See CAUTION NOTE 1, C.
 E) Repeat A & B. If the game is correct, it is now ready to play.* If the game is not correct, refer to Module Replacement Procedure. (See Parts List.)
- 7) **SYMPTOM:** Game blows fuse(s) repeatedly.
ACTION: See Module Replacement Procedure. F.O. 560

*Turn power On-Off switch OFF and then ON.

**GAME #1196 XENON (FIGURE V)
SOLENOID IDENTIFICATION TABLE**

Self Test #	SOLENOID IDENTIFICATION	Self Test #	SOLENOID IDENTIFICATION
01	OUTHOLE KICKER	10	LOWER THUMPER BUMPER
02	KNOCKER	11	4 DROP TARGET RESET
03	BALL RELEASE	12	#1 DROP TARGET
04	SIDE SAUCER	13	#2 DROP TARGET
05	LEFT SLINGSHOT	14	#3 DROP TARGET
06	RIGHT SLINGSHOT	15	#4 DROP TARGET
07	LEFT THUMPER BUMPER	16	COIN LOCKOUT DOOR
08	RIGHT THUMPER BUMPER	17	KI RELAY (FLIPPER ENABLE)
09	MIDDLE THUMPER BUMPER	18	TOP SAUCER

SWITCH ASSEMBLY SELF-TEST DISPLAY NUMBERS

Switch Self Test #	DESCRIPTION	Switch Self Test #	DESCRIPTION
01	END OF TUBE LANE	21	#4 DROP TARGET
02	BALL RELEASE #1	22	#3 DROP TARGET
03	UPPER SIDE TARGET	23	#2 DROP TARGET
04	LOWER SIDE TARGET	24	#1 DROP TARGET
05	SPINNER	25	SHOOTER LANE
06	CREDIT BUTTON	26	30 POINT REBOUND (2)
07	TILT (3)	27	TUBE SWITCH
08	OUTHOLE	28	BALL RELEASE #2
09	COIN III (RIGHT)	29	LEFT OUTLANE
10	COIN I (LEFT)	30	FLIP FEED LANE (LEFT)
11	COIN II (MIDDLE)	31	FLIP FEED LANE (RIGHT)
12		32	RIGHT OUTLANE
13		33	SIDE SAUCER
14		34	TOP SAUCER
15		35	RIGHT SLINGSHOT
16	SLAM (2)	36	LEFT SLINGSHOT
17	#4 BUTTON	37	LOWER THUMPER BUMPER
18	#3 BUTTON	38	MIDDLE THUMPER BUMPER
19	#2 BUTTON	39	RIGHT THUMPER BUMPER
20	#1 BUTTON	40	LEFT THUMPER BUMPER

**NOTE: SLINGSHOT & THUMPER BUMPER COILS
WILL BE ENERGIZED WHEN SWITCH IS MADE**

#1196 XENON

○ INDICATES SWITCH ASSEMBLY IDENTIFICATION NUMBERS.
 NOTE: CABINET: 07, 16
 DOOR: 06, 09
 10, 11, 16

□ INDICATES SOLENOID IDENTIFICATION NUMBERS.
 NOTE: DOOR: 16
 BACKBOX: 17
 CABINET: 02

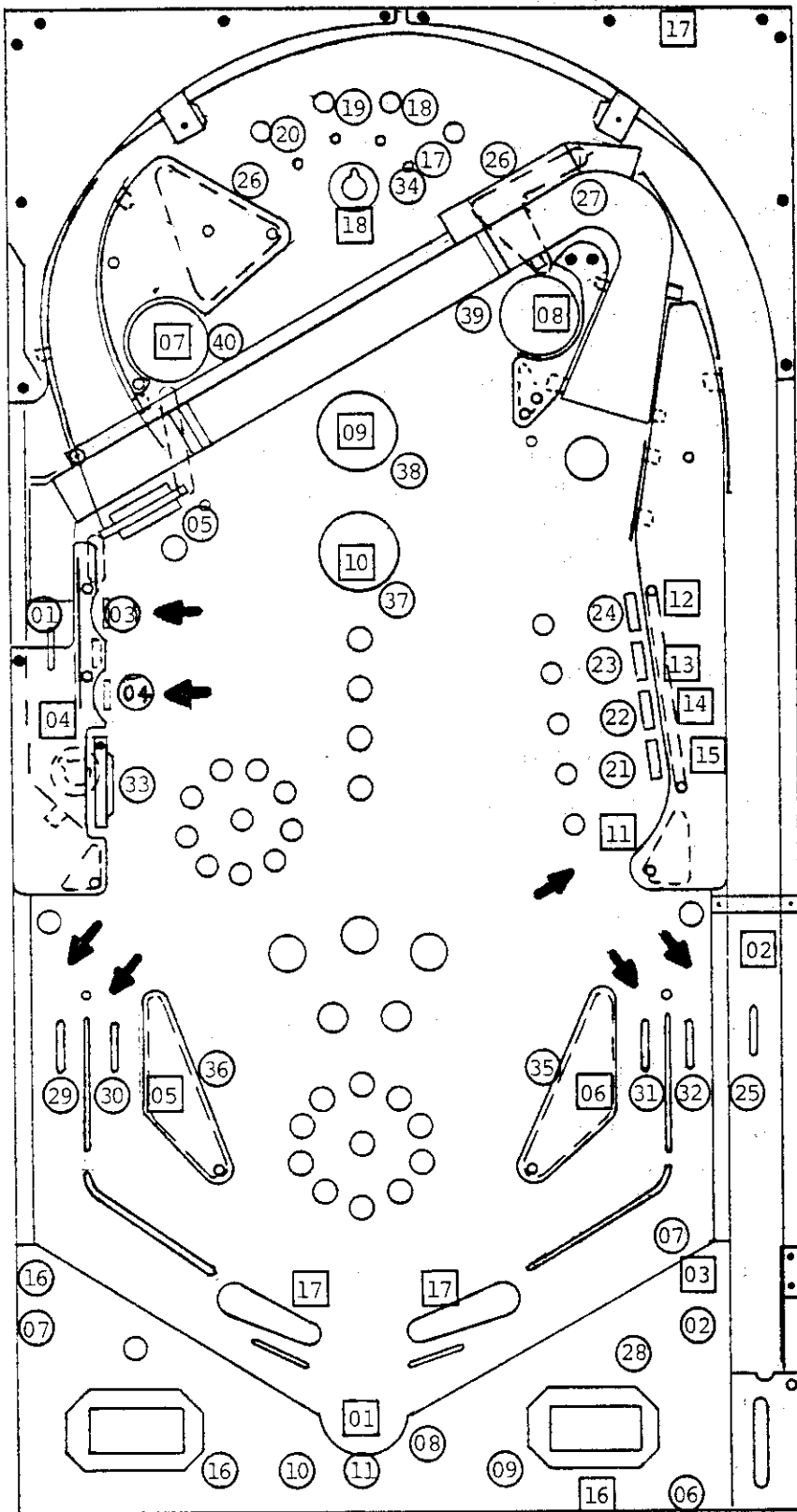

FIGURE V

ASSEMBLY ADJUSTMENTS:

GENERAL:

All switch assemblies consist of leaf springs, contacts, separators, plastic tubing and screws to hold them to the mounting surface. Before attempting to adjust a switch assembly, make sure that these screws are tight. If not, tighten screw closest to the contact end of the leaf spring first. This will prevent the assembly from being secured in such a manner that the leaf springs tend to fan out. In general, all leaf springs are adjusted for a 1/16" gap in the open position and .010" overtravel or wipe in the closed position. All contacts should be in good condition. Unless otherwise instructed, they should be dry or non-lubricated. All contacts should be free of dust and dirt. Contacts, with the exception of the flipper button switch assemblies, are plated to resist corrosion. Filing or burnishing breaks the finish and encourages corrosion. Clean by closing the contacts over a clean piece of paper (e.g. a business card) and wiping gently until the contacts are clean. For the flipper button switch assemblies **ONLY**: Tarnish can be removed with a contact file followed by a burnishing tool. Severely pitted contacts must be replaced as an assembly. In general, contacts need be cleaned or replaced and adjusted only when they are found to be a source of game malfunction.

X. SERVICE PARTS:

A parts catalogue is available upon request. The catalogue is illustrated and lists all replacement parts for each game manufactured by Bally. Requests should be addressed to:

BALLY MANUFACTURING CORPORATION
2640 WEST BELMONT AVENUE
CHICAGO, ILLINOIS 60618
ATTN: PARTS DEPARTMENT

SERVICE HINTS:

The Bally playfield has an improved tuff-coat finish with excellent wearing properties. Its life expectancy, as well as play appeal, can be extended by periodic cleaning of the playfield.

DO: Bally recommends you clean your playfield with Wildcat #125 (Wildcat Chemical Co., 1333 W. Seminary Drive, Ft. Worth, Texas 76115). Wildcat #125 is a combination cleaner and polish. Bally has tried and tested this product and found it to be very effective. If Wildcat #125 is not available, Bally suggests you ask your Distributor to order it. Inspect and hand polish the ball in a clean cloth. A chipped ball must be replaced. It can ruin the finish on the playfield in a short period of time.

DON'T: Use water in large quantities, highly caustic cleaners, abrasive cleaners or cleaning pads on the playfield. Do not allow a wax or polish build up. Waxes yellow with age and spoil play appeal.

XI. PARTS LIST

#1196 XENON

MISCELLANEOUS	PART NUMBER
Transformer (Domestic or Export)	E-122-142
Bulbs, #44	E-125-22
Fuse, 1 Amp. 3 AG Slow Blow (Playfield Solenoid Protection)	E-133-44
 ASSEMBLY COILS	
Coin Lockout	FO-36-7000
Flipper (2)	AQ-25-500/ 34-4500
Knocker	AR-26-1200
Outhole Kicker	AN-26-1200
Thumper-Bumper (4)	AN-26-1200
Sling-Shot (2)	AN-26-1200
Drop Target Reset	NO-26-1900
Individual Drop Targets (4)	CJ-31-2000
Saucer (2)	AO-27-1300
Ball Release	AO-27-1300
 PLAYFIELD PARTS	 See Figure II
 MODULES	
Lamp Driver A5	AS-2518-23
Display Driver A1 (1 used)	AS-2518-21
Display Driver A1 (4 used)	AS-2518-58
Solenoid Driver/Voltage Regulator A3	AS-2518-22
MPU A4	AS-2962-21
Transformer & Rectifier A2	AS-2877-6
Rectifier Board (Part of A2)	AS-2518-54
Sounds Plus	AS-3060
Auxiliary Lamp Driver A9	AS-2518-52
Vocalizer	AS-3059
 REPAIRS PROCEDURES/AIDS	
Module & Component Replacement	F.O.560-1
AID (Assistance in Diagnostics)	
Kit, used with F.O.560-1	KIT #485-1
 MODULE COMPONENTS	
SEE MODULE PARTS LIST	
 MODULE COMPONENT STARTER KITS	
(Each Kit contains an assortment of the most needed electronic parts for use in Module repair.)	
Kit #558—For Rectifier Board (Part of A2)	
Kit #503—For MPU Board A4 (Less Memory U1-U6)	
Kit #492—For Solenoid Driver/Voltage Regulator A3	
Kit #493—For Display Driver A1	
Kit #494—For Lamp Driver A5	
Kit #559—For Sound A8	

AS-2518-35 MPU MODULE

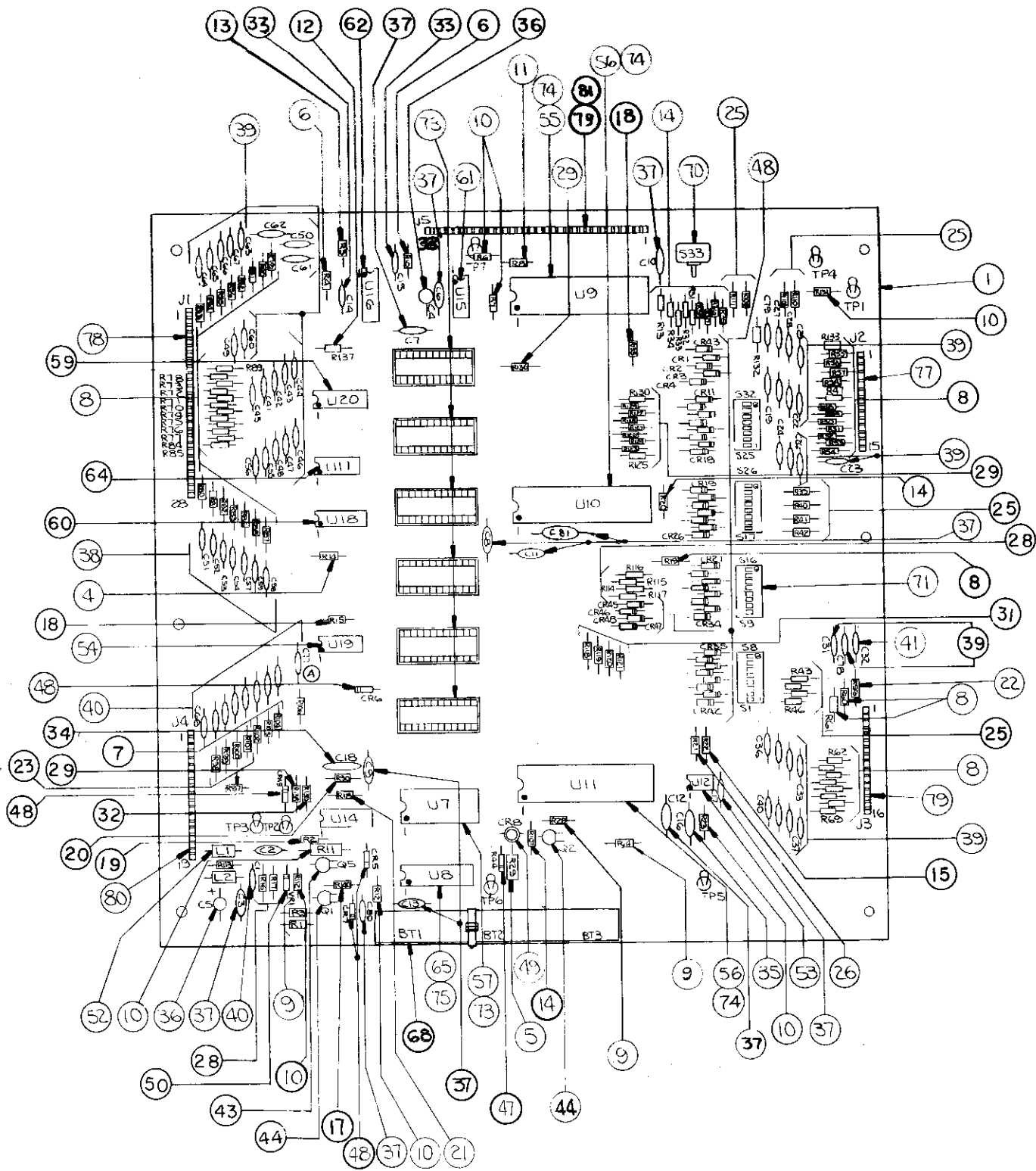

A4: MPU MODULE COMPONENT PARTS LIST

ITEM	REFERENCE DESIGNATION	BALLY PART #	DESCRIPTION
1	A4 (see note 1)	AS-2962-21	MPU Module Complete.
2	A4 (see note 2)	AS-2518-35	MPU Module less Program Memory, U1-6 incl.
3-32	See Schematic		Resistors, See schematic for value
33	C14, C15	E-00586-0067	Capacitor, 470 PFD, 1kv
34	C18	E-00586-0088	Capacitor, .05 MFD, 16V
35	C16	E-00586-0081	Capacitor, .1 MFD, 100V
36	C4, C5	E-00586-0073	Capacitor, 4.5 MFD, 25V
37	C3, C6-C13, C17, C81	E-00586-0085	Capacitor, .01 MFD, 25V
38	C79, C41-C67	E-00586-0083	Capacitor, 470 PFD, 50V
39	C19-C31, C78, C33-C40	E-00586-0082	Capacitor, 390 PFD, 50V
40	C1, C2, C68-C77	E-00586-0084	Capacitor, 820 PFD, 50V
41	C32	E-00586-0077	Capacitor, 3000 PF, 1kv
43	Q5	E-00585-0023	Transistor PNP (MPS-3702)
44	Q1, Q2	E-00585-0031	Transistor (2N3904)
47	CR44	E-00587-0006	Diode (IN4004)
48	CR1-CR7, CR11-CR43, CR45-CR49	E-00587-0014	Diode (IN4148)
49	CR8	E-00679	LED (Green)
50	VR1	E-00598-0008	Diode Zener (8.2V, IN9598)
52	L1, L2	E-00604-0003	Inductor, 22 Micro Hy.
53	U12	E-00620-0004	Timer (555)
54	U19	E-00620-0005	Quad 2 Input (4011)
55	U9	E-00620-0028	MPU I.C. (6800)
56	U10, U11	E-00620-0029	PIA I.C. (6820)
57	U7	E-00620-0030	RAM I.C. (6810)
59	U20	E-00620-0032	HEX Buffer I.C. (14502B)
60	U14, U18	E-00620-0033	HEX Inverter (4049B)
61	U15	E-00620-0034	Quad Memory Drive (MC3459L)
62	U16	E-00620-0035	Dual Monostable (9602)
64	U17	E-00620-0041	Quad 2 Inputs (74L00N)
65	U8	E-00620-0042	RAM (C MOS, P5101L-3)
68	BT1, BT2, BT3	E-00628-0003	Battery
70	S33	E-00658-0001	Push Button Switch
71	S1-S8, S9-S16, S17-S24, S25-S32	E-00677	DIP Switch
73		E-00712	24 Pin Socket
74		E-00712-0001	40 Pin Socket
75		E-00712-0003	22 Pin Socket
77	J2	E-00715	15 Pin Wafer Connector
78	J1	E-00715-0004	28 Pin Wafer Connector
79	J3, J5	E-00715-0017	16 Pin Wafer Connector
80	J4	E-00715-0018	19 Pin Wafer Connector
81	J5	E-00715-0024	17 Pin Wafer Connector

NOTE 1:

When ordering, fill in dash number. For example, AS-2962-0: LOST WORLD, AS-2962-2: SIX MILLION DOLLAR MAN, AS-2962-3: PLAYBOY, AS-2962-4: VOLTAN, AS-2962-5: SUPERSONIC, AS-2962-6: STAR TREK, AS-2962-7: KISS, AS-2962-8: PARAGON, AS-2962-9: GROUND SHAKER, AS-2962-10: HARLEM GLOBETTERS, AS-2962-12: DOLLY PARTON, AS-2962-13: SILVERBALL MANIA, AS-2962-18: MYSTIC, AS-2962-20: HOTDOGGIN, AS-2962-22: SKATEBALL, AS-2963-23: FRONTIER AS-2962-21: XENON

NOTE 2: Order replacement memory chips U1-U6, specifying game, socket and part number stamped on chip.

AS-2518-23 LAMP DRIVER MODULE

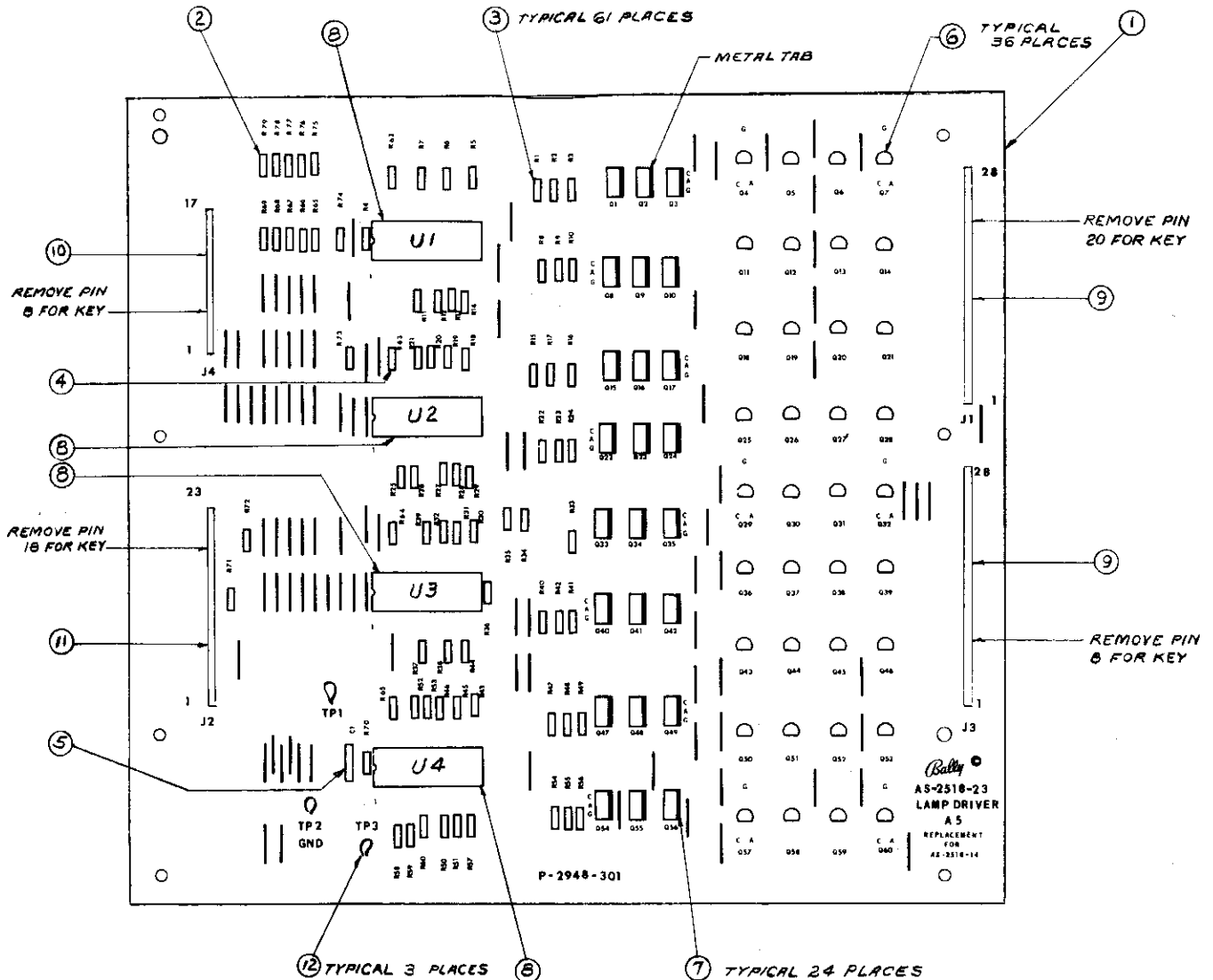

A5: LAMP DRIVER MODULE COMPONENT PARTS LIST

ITEM	REFERENCE DESIGNATION	BALLY PART #	DESCRIPTION
1	A5	AS-2518-23	Lamp Driver Module, Complete
2	R71-R79	E-00105-242	Resistor, 20k Ω , 5%, 1/4 W
3	R1-R60, R70	E-00105-0237	Resistor, 2k Ω , 5%, 1/4 W
4	R61-R69	E-00105-0256	Resistor, 2.2M Ω , 1/4 W
5	C1	E-00586-0065	Capacitor, .01 MFD, 500V
6	Q4-Q7, Q11-Q14, Q18-Q21, Q25-Q32, Q36-Q39, Q43-Q46, Q50-Q53, Q57-Q60	E-00585-0014	SCR, 2N5060
7	Q1-Q3, Q8-Q10, Q15-Q17, Q22-Q24, Q33-Q35, Q40-Q42, Q47-Q49, Q54-Q56	E-00585-0029	SCR, MCR106-1
8	U1-U4	E-00620-0037	I.C., Decoder, 14514B
9	J1, J3	E-00715-0004	28 Pin Wafer Connector
10	J4	E-00715-0024	17 Pin Wafer Connector
11	J2	E-00715-0014	23 Pin Wafer Connector
12	TP1, TP2, TP3	P-05399	Test Clip

AS-2518-21 CREDIT DISPLAY DRIVER MODULE

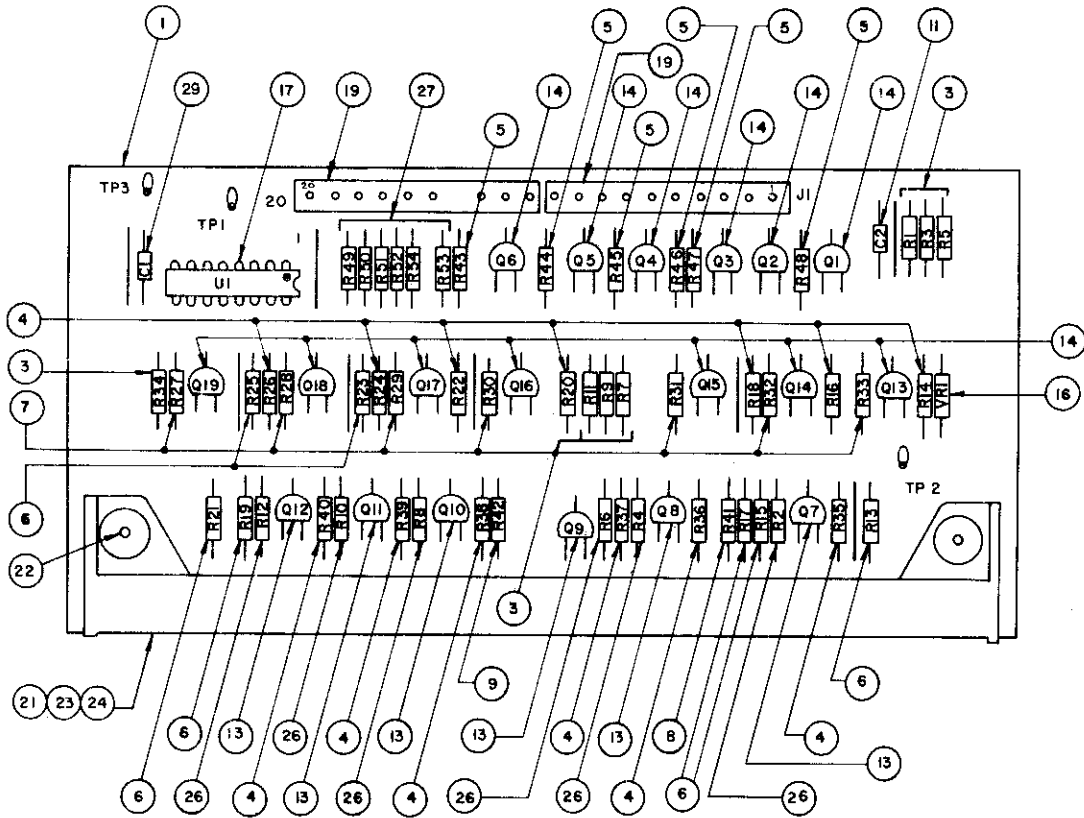

A1: 6 DIGIT DISPLAY DRIVER MODULE COMPONENT PARTS LIST

ITEM	QTY.	REFERENCE DESIGNATION	BALLY PART #	DESCRIPTION
1	1		P-2948-296	P.C. Board, M-645-392
3	7	R1, R3, R5, R7, R9, R11, R34	E-105-331	Resistor, 100K Ω
4	13	R14, R16, R18, R20, R22, R24, R26, R35, R36, R37, R38, R39, R40	E-105-227	Resistor, 300K Ω
5	6	R43, R44, R45, R46, R47, R48	E-105-228	Resistor, 9.1K Ω
6	7	R13, R15, R17, R19, R21, R23, R25	E-105-229	Resistor, 1.5K Ω
7	7	R27, R28, R29, R30, R31, R32, R33	E-105-222	Resistor, 1.2K Ω
8	1	R41	E-105-231	Resistor, 39K Ω
9	1	R42	E-105-271	Resistor, 240K Ω
10				
11	1	C2	E-586-65	Capacitor, .01 MFD, 500V
13	6	Q7, Q8, Q9, Q10, Q11, Q12	E-585-32	Transistor (2N5401)
14	13	Q1, Q2, Q3, Q4, Q5, Q6, Q13, Q14, Q15, Q16, Q17, Q18, Q19	E-585-33	Transistor (MPS-A42)
16	1	VR1	E-598-7	Zener Diode, 110V
17	1	U1	E-620-38	I.C. Decoder
18				
19	2	J1	E-715-34	10 Pin Wafer Pin Connector
21	1	DS1	E-680	Digital Display Panel
22	2		M-1836	Hi-Lo Screw, W/H
23	1		P-2399	Display Mounting (Top)
24	1		P-2399-1	Display Mounting (Bottom)
26	6	R2, R4, R6, R8, R10, R12	E-105-287	Resistor, 2.2K Ω
27	6	R49, R50, R51, R52, R53, R54	E-105-242	Resistor, 20K Ω
28	As Req'd			Wire Jumper
29	1	C1	E-586-85	Capacitor, .01 MFD, 25V

NOTE: INTERCHANGEABLE WITH AS-2518-15

AS-2518-22 SOLENOID DRIVER/VOLTAGE REGULATOR MODULE

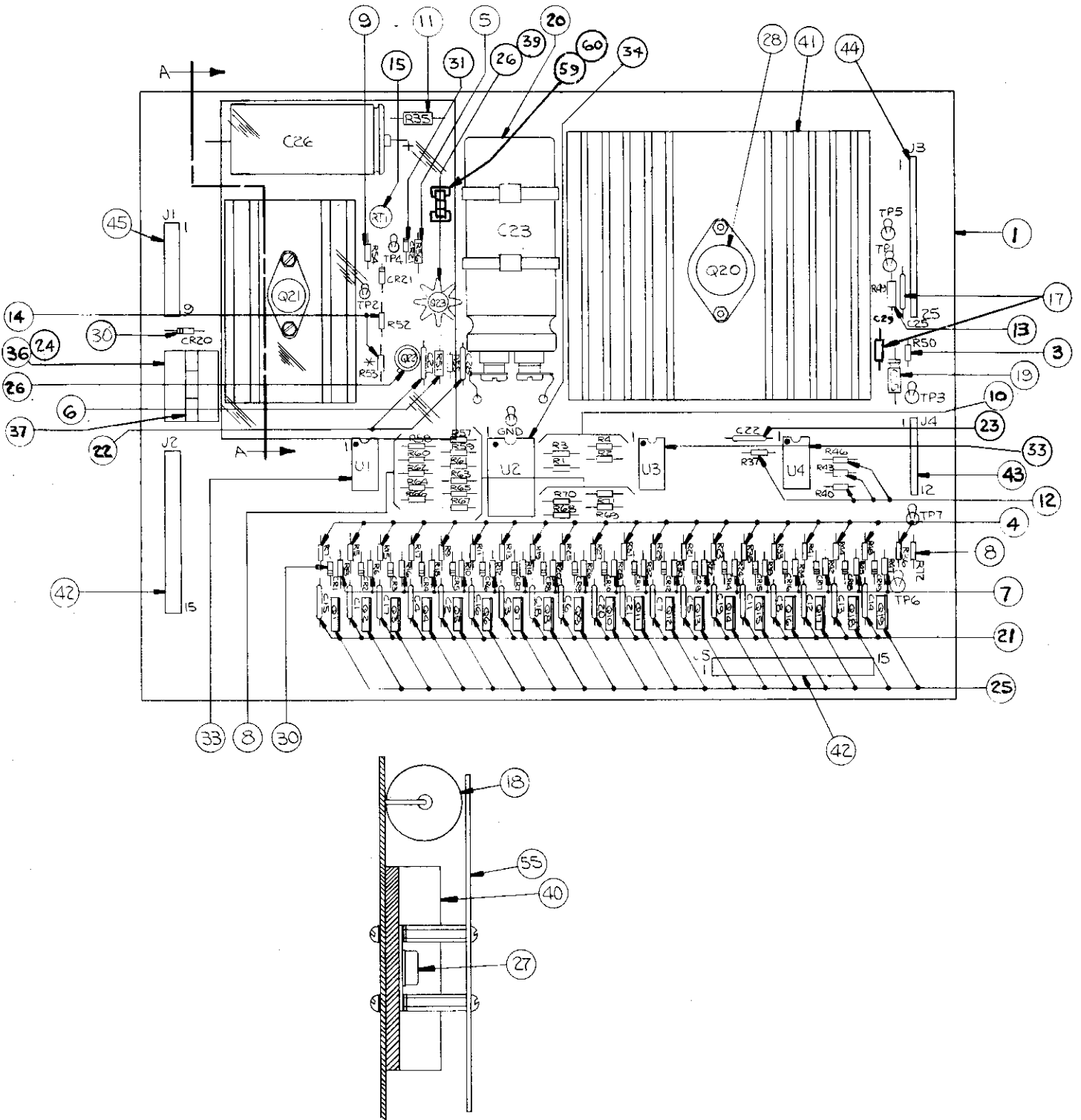

NOTE: INTERCHANGEABLE WITH AS-2518-16

A3: SOLENOID DRIVER/VOLTAGE REGULATOR MODULE

COMPONENT PARTS LIST

ITEM	REFERENCE DESIGNATION	BALLY PART #	DESCRIPTION
1	A3	AS-2518-22	Solenoid Driver/Voltage Regulator Module, Complete
3-14	Resistors		Resistor, See Schematic for value.
15	RT1	E-00599-0014	Pot. (Linear) 25K
17	C25, 29	E-00586-0014	Capacitor, .1 MFD, 20V
18	C26	E-00586-0059	Capacitor, 160 MFD, 350V
19	C24	E-00586-0063	Capacitor, 2 MFD @ 25V
20	C23	E-00586-0062	Capacitor, 11700 MFD, 20V
21	C1-C8, C11-C21	E-00586-0064	Capacitor, .002 MFD, 1kv
22	C27, C28	E-00586-0065	Capacitor, .01 MFD, 500V
24	K1	E-00146-0795	Relay, Printed Circuit
25	Q1-Q19	E-00585-0034	Transistor, SE9302
26	Q22, Q23	E-00585-0041	Transistor, 2N3440
27	Q21	E-00585-0042	Transistor, 2N3584
28	Q20	E-00710	+5V Regulator, LAS1405 or 78H05KC or LM323K
30	CR1-CR21	E-00587-0015	Diode (IN4004)
31	VR1	E-00598-0010	Diode, Zener 140V, IN5275A
33	U1, U3, U4	E-00681	I.C. Transistor Array, CA3081
34	U2	E-00620-0039	I.C. Binary to 1/16 Decoder, 74L154
36		E-00592-0002*	Relay Socket
37		M-1839*	Relay Holder
39		E-00682	Heat Sink, TO5
40		E-00682-0001	Heat Sink, TO66
41		E-00682-0002	Heat Sink, TO3 Case
42		E-00715-0039	15 Pin Wafer Connector
43		E-00715-0016	12 Pin Wafer Connector
44		E-00715-0020	25 Pin Wafer Connector
45		E-00715-0033	9 Pin Wafer Connector
55		M-1838	Shield-Plexiglass
59		E-00148-0021	Fuse Clips
60	F1	E-00133-0029	Fuse 8 AG-3/16 Amp.
23	C22	E-00586-0085	Capacitor, .01 MFD, 25V

*USED WITH ITEM 24, E-00146-0791, PLUG IN RELAY ONLY

A2: POWER TRANSFORMER MODULE

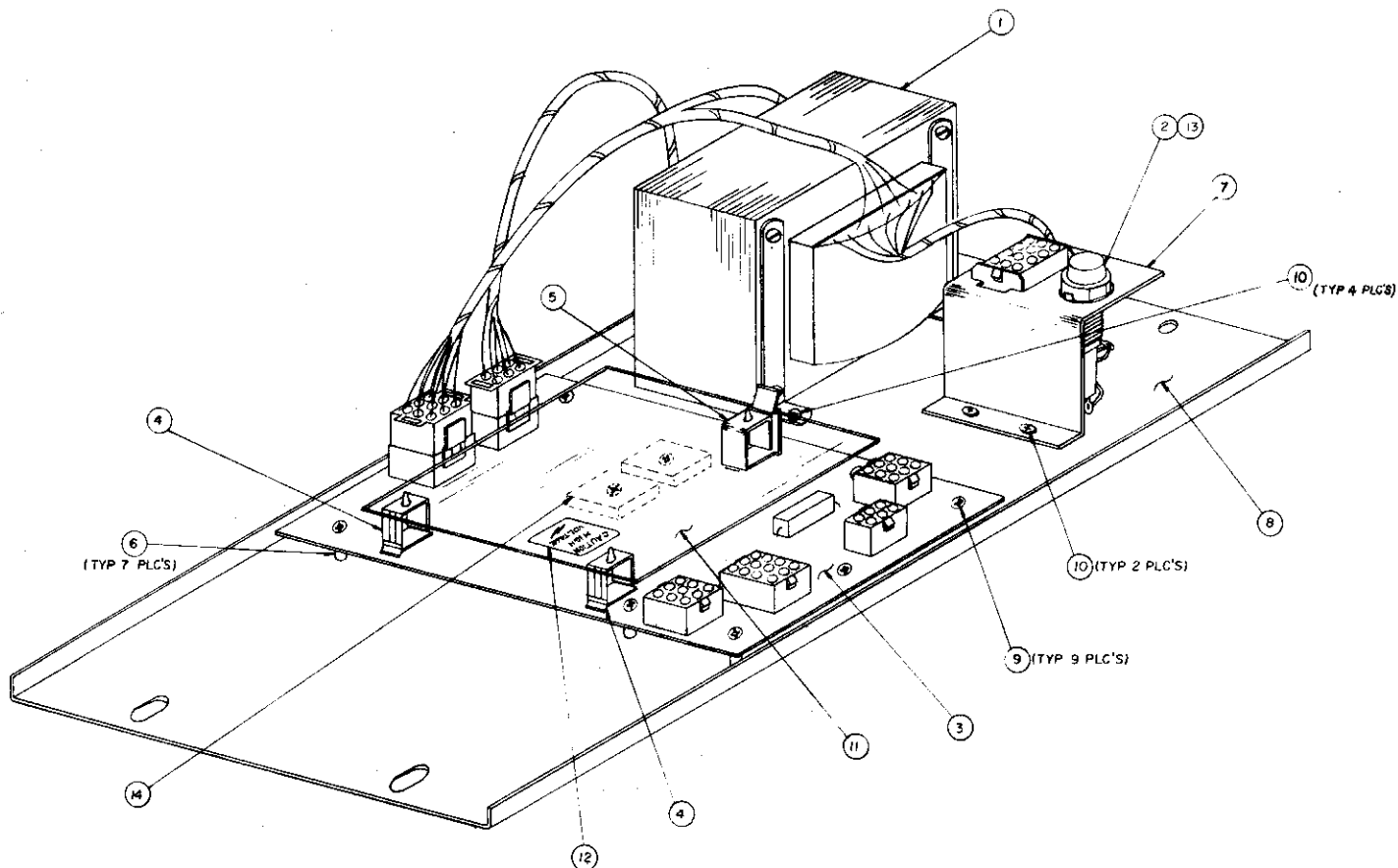

COMPONENT PARTS LIST

ITEM	REFERENCE DESIGNATION	BALLY PART #	DESCRIPTION
0	A2	AS-2877-6	Power Transformer Module, Complete
1		AS-3071-2	Transformer
2		E-148-25	Fuse Holder
3	A2	AS-2518-54	Power Module Assy.
4		M-1829-4	Hinged Support
5		M-1829-3	Edge Holder
6		M-1829-5	Spacer
7		P-6442-244b	Fuse & Connect Brkt.
8		P-6442-246	Chassis
9		RLPP-832-1812	Screw
10		RLPP-1032-1806	Screw
11		P-2692-2	Shield
12		M-469-936a	High Voltage Sticker
13		E-133-24	3A S.B. Fuse
14		M-1834	H. S. Compound

AS-2518-54 RECTIFIER BOARD ASSEMBLY

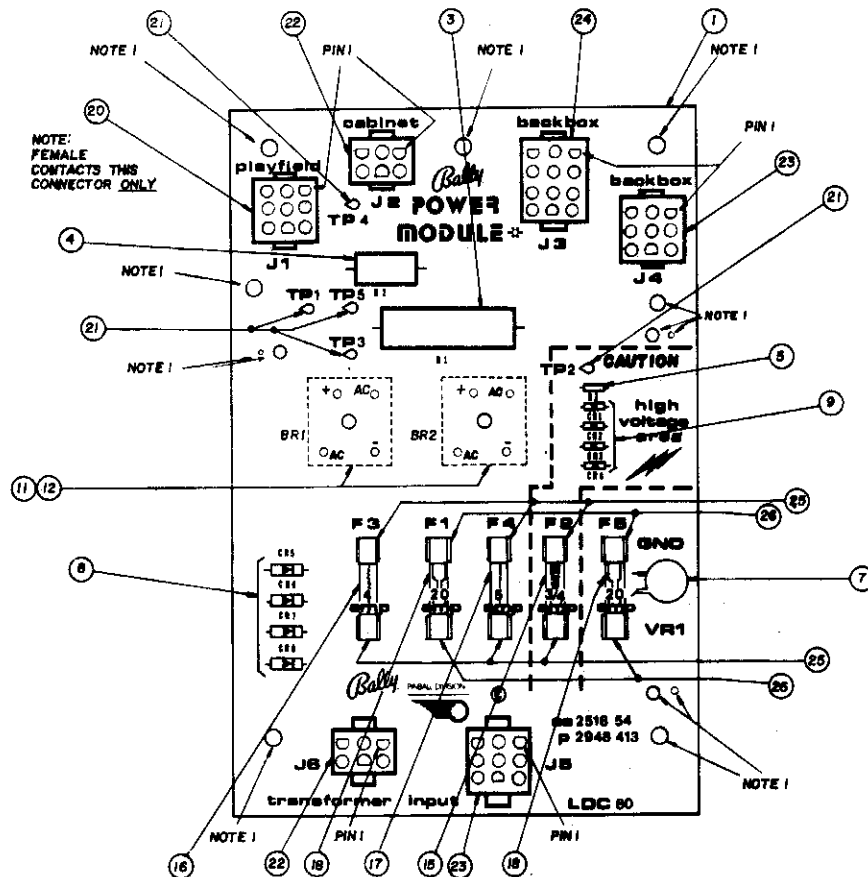

(Part of) A2: POWER TRANSFORMER MODULE COMPONENT PARTS LIST

ITEM	REFERENCE DESIGNATION	BALLY PART #	DESCRIPTION
0	A2	AS-2877-6	Power Transformer Module, Complete
1	P/O A2	AS-2518-54	Rectifier Board Assembly, Complete
3	R1	E-00104-0092	Resistor, 10%, 600 Ohm, 10W
4	R2	E-00104-0091	Resistor, 25 Ohm, 5W
5	R3	E-00105-0226	Resistor, 5%, 100K Ohm, 1/4W
7	VR1	E-00623	Varistor
8	CR5, CR6, CR7, CR8	E-00587-0022	3A Diode
9	CR1, CR2, CR3, CR4	E-00587-0015	Diode (IN4004)
10			
11	Used with BR1-2	P-1973-480	Spacer
12	BR1, BR2	E-00602-0006	Bridge Rectifier
15	F2	E-00133-0028	Fuse, 1/4A, 250V, 3AG
16	F3	E-00133-0004	Fuse, 4A, 32V, 3AG
17	F4	E-00133-0005	Fuse 5A, 32V, 3AG
18	F1, F5	E-00133-0027	Fuse, 20A, 32V, 3AG
19			
20	J1	E-806-9	9 CKT Socket Header
21	TP1, 2, 3, 4, 5	P-05399	Test Clip
22	J2, J6	E-805-6	6 CKT Pin Header
23	J4, J5	E-805-9	9 CKT Pin Header
24	J3	E-805-12	12 CKT Pin Header
25	F2, 3, 4	E-00148-0021	Fuse Clips
26	F1, 5	E-00148-0022	Fuse Clips (Low Resistance)

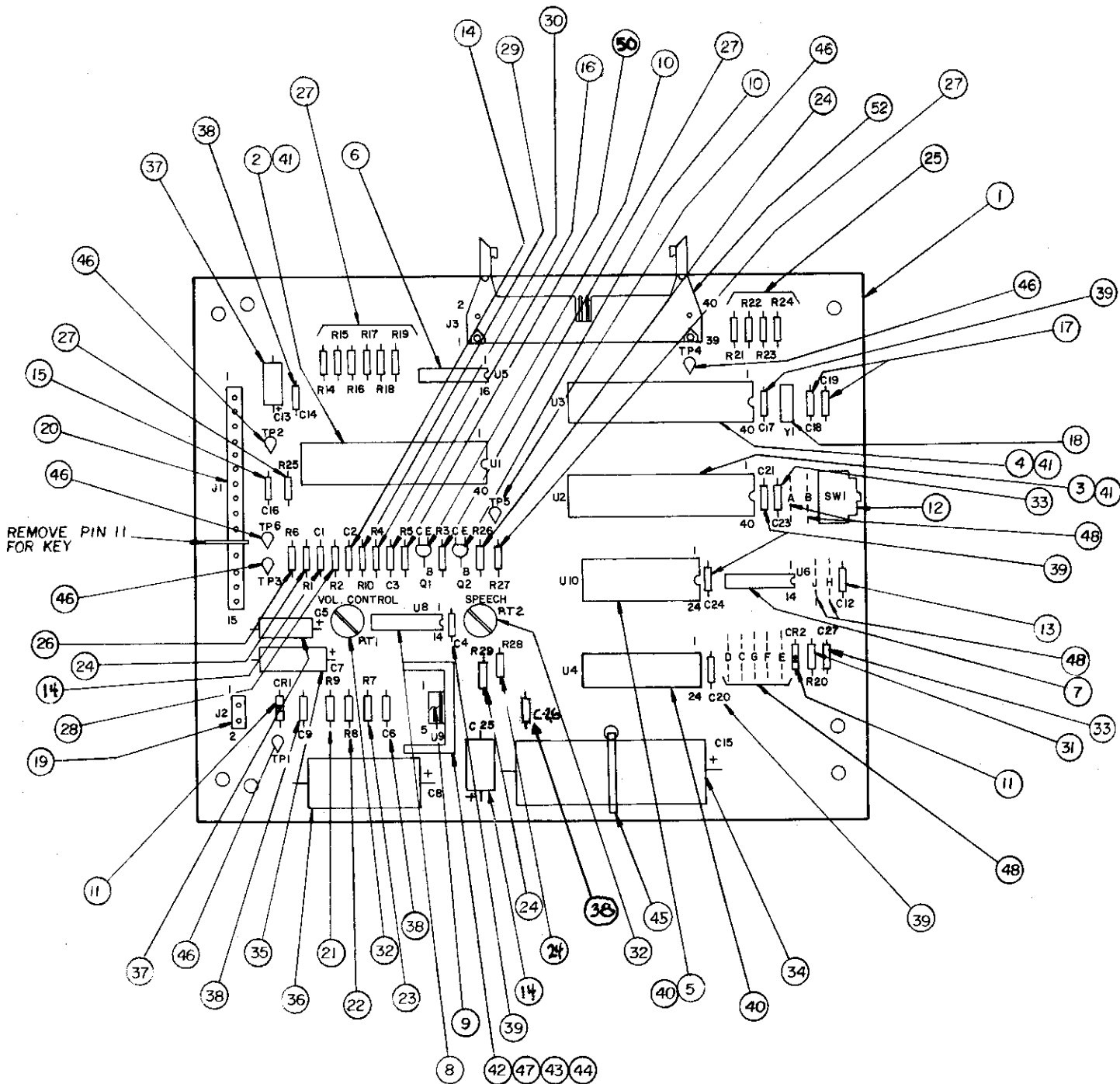

AS-2518-56 SOUNDS PLUS MODULE COMPONENT PARTS LIST

ITEM	REFERENCE DESIGNATION	BALLY PART #	DESCRIPTION
1	A8	P-2948-240	P.C.B M-645-535
2	U1	E-620-124	Sound Chip AY-3-8910
3	U2	E-620-29	P1A, 6820/1
4	U3	E-620-125 (E-620-128)	CPU, 6808 (6802 Note 1)
5	U10	E-620-30	RAM,6810 (Note 1)
6	U5	E-620-33	Hexinverter 4049B
7	U6	E-620-170	Quad 2 Input 4093CP
8	U8	E-620-126	AMP, LM3900
9	U9	E-620-127	Power Amp, TDA 2002
10	Q1, Q2	E-585-31	Transistor, 2N3904
11	CR1, 2	E-587-6	Diode, 1N4004
12	SW1	E-658-1	Switch
13	C12	E-585-118	Cap. .2MF \pm 20% Y5P, 16 V.
14	C1, C2, C25	E-586-130	Cap. .47MF \pm 20% Z5V, 16 V.
15	C16	E-586-83	Cap. 470 PF 50 V.
16	C3	E-586-120	Cap. 68 PF, \pm 20% 1 K.
17	C18, 19	E-586-121	Cap. 27 PF, \pm 20% 1 K.
18	Y1	E-744-5	Crystal, 3.579545 MHZ
19	J2	E-736-2	Connector, Wafer, 2 Pin KK156
20	J1	E-736-15	Connector, Wafer, 15 Pin KK156
21	R9	E-105-196	Resistor, 1 Ohm, 1/4 W., 5%
22	R8	E-105-211	Resistor, 2.2 Ohm, 1/4 W., 5%
23	R7	E-105-303	Resistor, 220 Ohm, 1/4 W., 5%
24	R1, R26, R29, R28	E-105-230	Resistor, 1 K, 1/4 W., 5%
25	R21, 22, 23, 24	E-105-238	Resistor, 3.3 K Ohm, 1/4 W., 5%
26	R6	E-105-239	Resistor, 4.7 K., 1/4 W., 5%
27	R3, 14, 15, 16 17, 18, 19, 25, 27	E-105-185	Resistor, 10 K., 1/4 W., 5%
28	R2	E-105-245	Resistor, 30K., 1/4 W. 5%
29	R10	E-105-345	Resistor, 91 K., 1/4 W., 5%
30	R4	E-105-225	Resistor, 200 K., 1/4 W., 5%
31	R20	E-105-285	Resistor, 1M, 1/4 W., 5%
32	RT1, RT2	E-599-16	Potentiometer 1K.
33	C23, C27	E-586-122	Cap. .001 MF \pm 20% 2SF
34	C15	E-586-123	Cap. 4700 MF 25 V.
35	C7	E-586-124	Cap. 470 MF 6 V.
36	C8	E-586-136	Cap. 1000 UF 16 V.
37	C5, 13	E-586-90	Cap. 1 MF 50 V.
38	C9, 14, 6, 26	E-586-89	Cap. .1 MF
39	C4, 17, 21, 20, 24	E-586-85	Cap. .01 MF
40	XU10, XU4	E-712	Socket, 24 Pin
41	XU1, XU2, XU3	E-712-1	Socket, 40 Pin
42	Used with 43	LSPR-00632-1106	Bolt, 6 x 32 x 3/8
43	Used with 42	N-00632-2112	Nut, 6 x 32
44	H.S. for U9	E-682-8	Heat Sink, 6030BTT
45	Used with C15	E-647-5	Ty Rap
46	TP1, 2, 3, 4, 5, 6	P-5399	Test Point
47	Use with 44, 9	M-1834	Thermal Grease
48	Jumpers A-J (See Notes)	W-1211c	22 AWG Wire, Solid Tinned Schematic
50	R5	E-105-344	Resistor 750 K. 1/4 W. 15%
52	J3	E-803-40	Connector

AS-2518-58 DISPLAY DRIVER MODULE

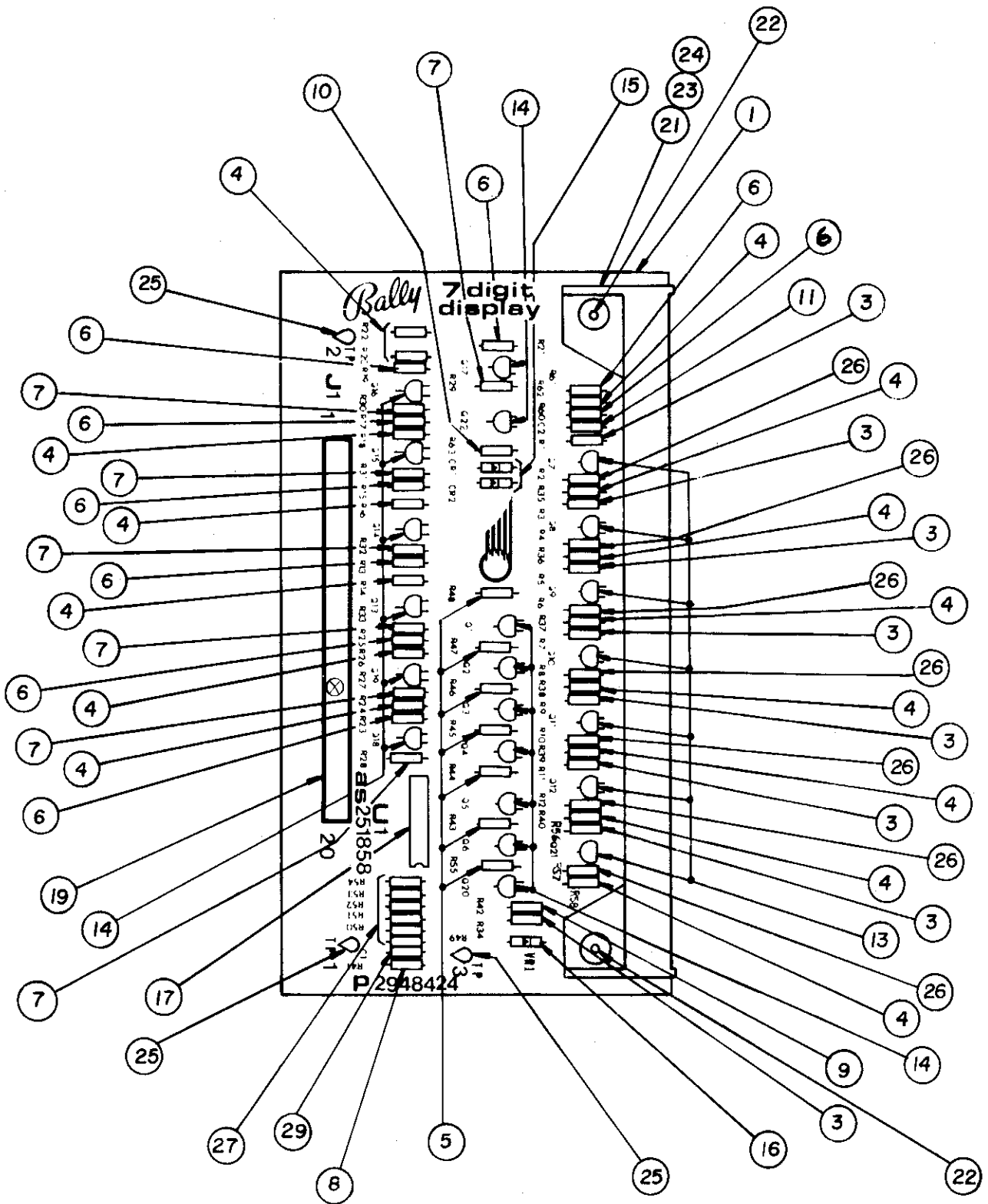

A1: 7 DIGIT DISPLAY DRIVER MODULE

COMPONENTS PARTS LIST

ITEM	QTY.	REFERENCE DESIGNATION	BALLY PART #	DESCRIPTION
1	1			
3	8	R1, R3, R5, R7, R9, R11, R34, R56	P-2948-424 E-105-331	P.C. Board, M-645 546 Resistor, 100K Ω
4	15	R14, R16, R18, R20, R22, R24, R26, R35, R36, R37, R38, R39, R40, R58, R62	E-105-227	Resistor, 300K Ω
5	7	R43, R44, R45, R46, R47, R48, R55	E-105-228	Resistor, 9.1K Ω
6	9	R13, R15, R17, R19, R21, R23, R25, R61, R60	E-105-229	Resistor, 1.5K Ω
7	7	R27, R28, R29, R30, R31, R32, R33	E-105-222	Resistor, 1.2K Ω
8	1	R41	E-105-231	Resistor, 39K Ω
9	1	R42	E-105-271	Resistor, 240K Ω
10	1	R63	E-105-248	Resistor, 150K Ω
11	1	C2	E-586-65	Capacitor, .01 MFD, 500V
13	7	Q7, Q8, Q9, Q10, Q11, Q12, Q21	E-585-32	Transistor (2N5401)
14	15	Q1, Q2, Q3, Q4, Q5, Q6, Q13, Q14, Q15, Q16, Q17, Q18, Q19, Q20, Q22	E-585-33	Transistor (MPS-A42)
15	2	CR1-2		
16	1	VR1	E-587-14	Diode (IN4148)
17	1	U1	E-598-7	Zener Diode, 110V (IN3045A)
18			E-620-38	I.C. Decoder (MC14543)
19	2	J1	E-736-10	10 Pin Wafer Pin Connector (KK-156)
21	1	DS1	E-680-7	7 Digital Display Panel
22	2		M-1836	Hi-Lo Screw, W/H
23	1		P-2399	Display Mounting (Top)
24	1		P-2399-1	Display Mounting (Bottom)
25	3	TP1-3	P-5399	Test Clip
26	7	R2, R4, R6, R8, R10, R12, R57	E-105-287	Resistor, 2.2K Ω
27	6	R49, R50, R51, R52, R53, R54	E-105-242	Resistor, 20K Ω
28				
29	1	C1	E-586-85	Capacitor, .01 MFD, 25V

**AS 2518-57 VOCALIZER MODULE ASSY.
COMPONENTS PARTS LIST**

ITEM	REFERENCE DESIGNATION	PART NO.	DESCRIPTION
1	A10	P-2948-421	P.C.B. Vocalizer M-645-536
2	Q1	E-620-140	Voltage Regulator LM7805
3	H.S. FOR Q1	E-682-14	Heatsink 6100B
4	USE FOR 2 & 3	LSPR-632-1106	Screw 6-32 X 3/8
5	USE FOR 2 & 3	N-632-2112	Nut 6-32
6	USE WITH 2	M-1834	Heat Sink Compound
7	J1	E-810-40	Connector Right Angle Header
8	FOR U1-U8	E-712	24 Pin P.C. Socket
9	U13	E-620-141	74LS30 8 Input NAND
10	U9	E-720-44	32 X 8 Prom
11	U10	E-620-138	MC3417 Delta Demod
12	U11	E-620-137	LM3403 Op Amp
13	U12	E-620-139	74LS04 Hex Inverter
14	C12, 14	E-586-131	470 PF Mono Capacitor 50 V.
15	C1-9, C23-24	E-586-85	.01 UF Ceramic Capacitor 25 V.
16	C10	E-586-89	.1 UF Disc Capacitor 25 V.
17	C11	E-586-90	1 UF Electrolytic Capacitor 25 V.
18	C16, 19, 13, 15	E-586-132	1000 PF 50 V. Mono Capacitor
19	C17, 20	E-586-133	2200 PF Mono Capacitor 50 V.
20	C18	E-586-134	.33 MF Disc Capacitor 16 V.
21	C21-22	E-586-88	.05 MF Ceramic Capacitor 16 V.
22	C25	E-586-91	100 UF Electrolytic Capacitor 25 V.
23	CR1-3	E-587-15	IN4004 Diode
24	R1-2, 17-26	E-105-185	10 K. Resistor 1/4 W. 5%
25			
26	R3-6	E-105-258	56 K. Resistor 1/4 W. 5%
27	R7-10	E-105-260	36 K. Resistor 1/4 W. 5%
28	R11	E-105-230	1 K. Resistor 1/4 W. 5%
29	R12, 15	E-105-238	3.3 K. Resistor 1/4 W. 5%
30	R13	E-105-335	5.1 M Resistor 1/4 W. 5%
31	R14	E-105-242	20 K. Resistor 1/4 W. 5%
32	R16	E-105-242	100 K. Resistor 1/4 W. 5%
33	A, B, C, D, E NOTE 1		Jumper 22 AWG Solid Tinned
34	TP1-6	P-5399	Test Clip

AS 2518-57 VOCALIZER MODULE ASSY.

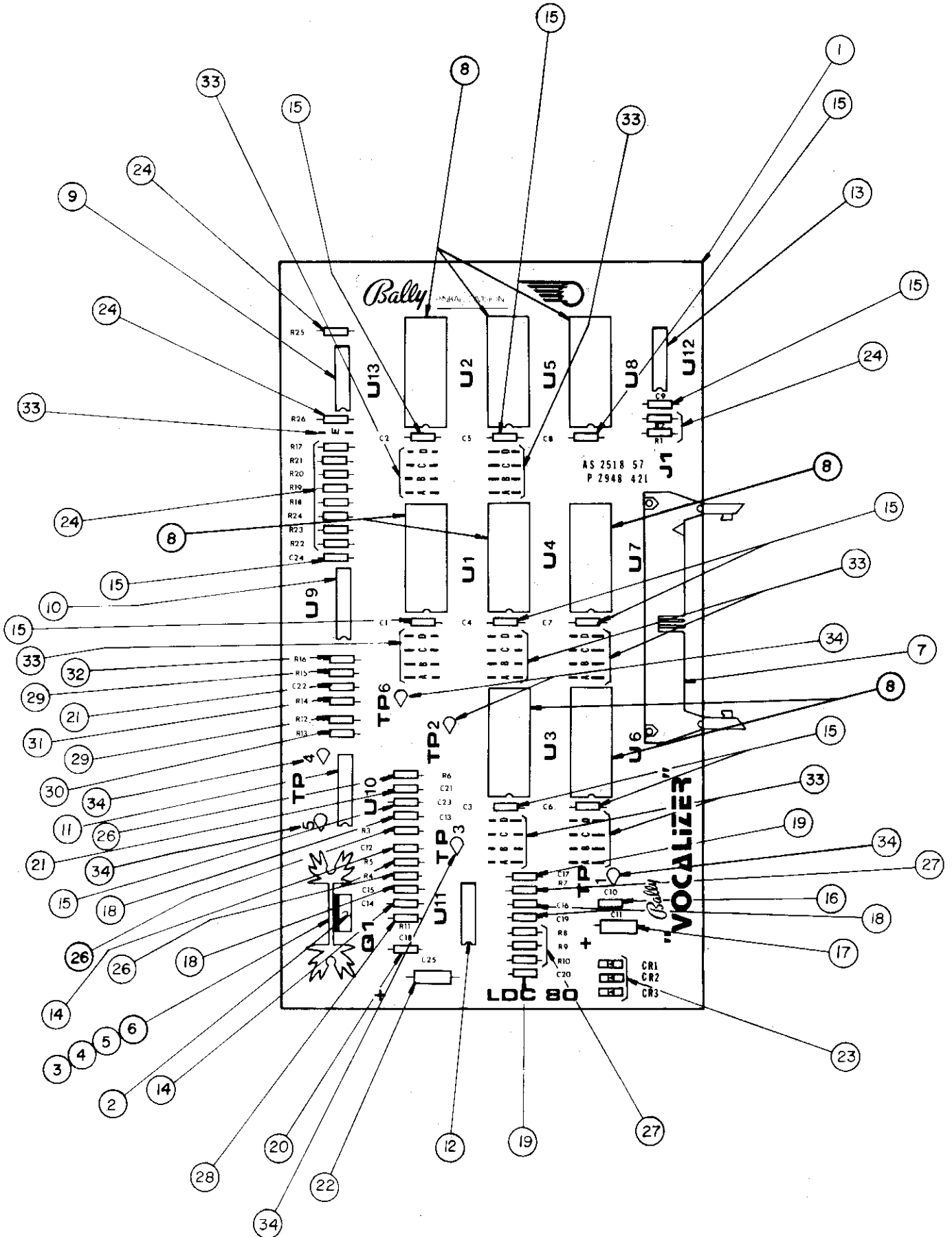

AS-2518-52 AUXILIARY LAMP DRIVER

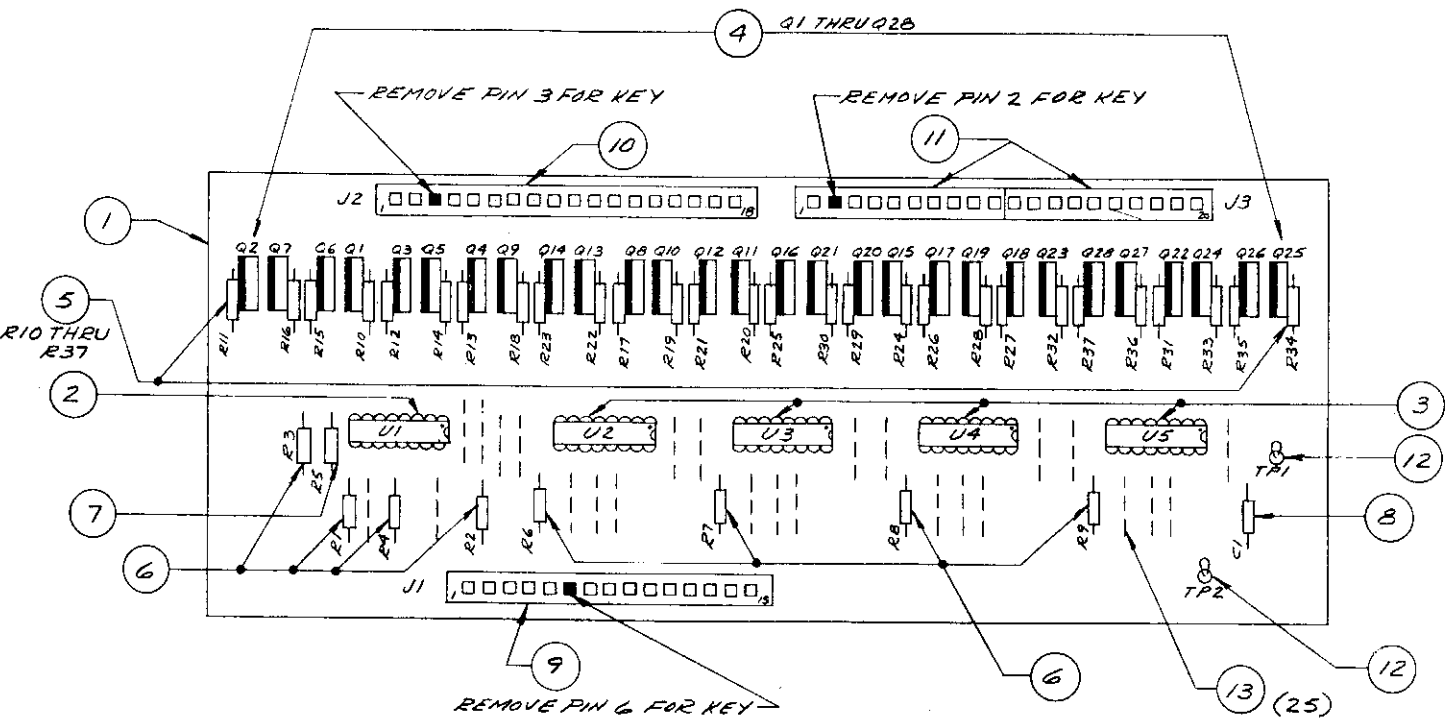

A9: AUXILIARY LAMP DRIVER COMPONENT PARTS LIST

ITEM	QTY.	REFERENCE DESIGNATION	BALLY PART NO.	DESCRIPTION
1	1		P-2948-504	P.C.B. (M-645-512)
2	1	U1	E-620-134	Quad Flip Flop
3	4	U2 Thru U5	E-620-108	BCD to Decimal Decoder
4	28	Q1 Thru Q28	E-585-29	S.C.R.
5	28	R10 Thru R37	E-105-237	Resistor, 2K Ω , 1/4 W, 5%
6	8	R1-4, R6-9	E-105-242	Resistor, 20K Ω , 1/4 W, 5%
7	1	R5	E-105-173	Resistor, 2.2M, 1/4 W, 5%
8	1	C1	E-586-85	Capacitor, .01 μ f, 25V, \pm 20 %
9	1	J1	E-736-15	Connector, KK156 15 Pin
10	1	J2	E-736-18	Connector, KK156 18 Pin
11	2	J3	E-736-10	Connector, KK156 10 Pin
12	2	TP1, TP2	P-5399	Test Point
13	25		M-1777-126	Jumper

AS-2518-60 LIGHT STRIP

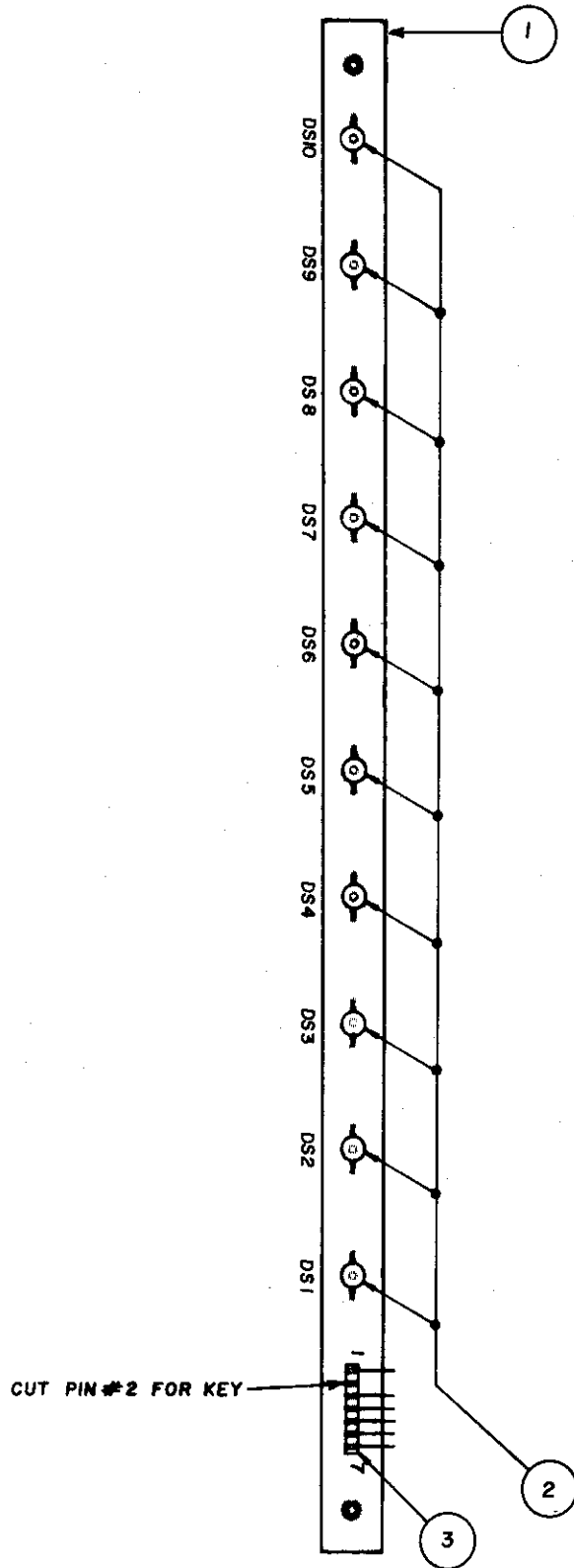

ITEM	REFERENCE DESIGNATION	PART NO.	DESCRIPTION
1	A12	P-2948-434	PCB Light Strip
2	DSI-DS 10	E-125-71	Miniature Light
3	J1	E-768-7	Connector KK100

VECTOR DRAWING FOR XENON
2 EJECT SAUCERS

Ball from top saucer exits
to right side of middle
thumper bumper.

Ball from left saucer exits
to right slingshot.

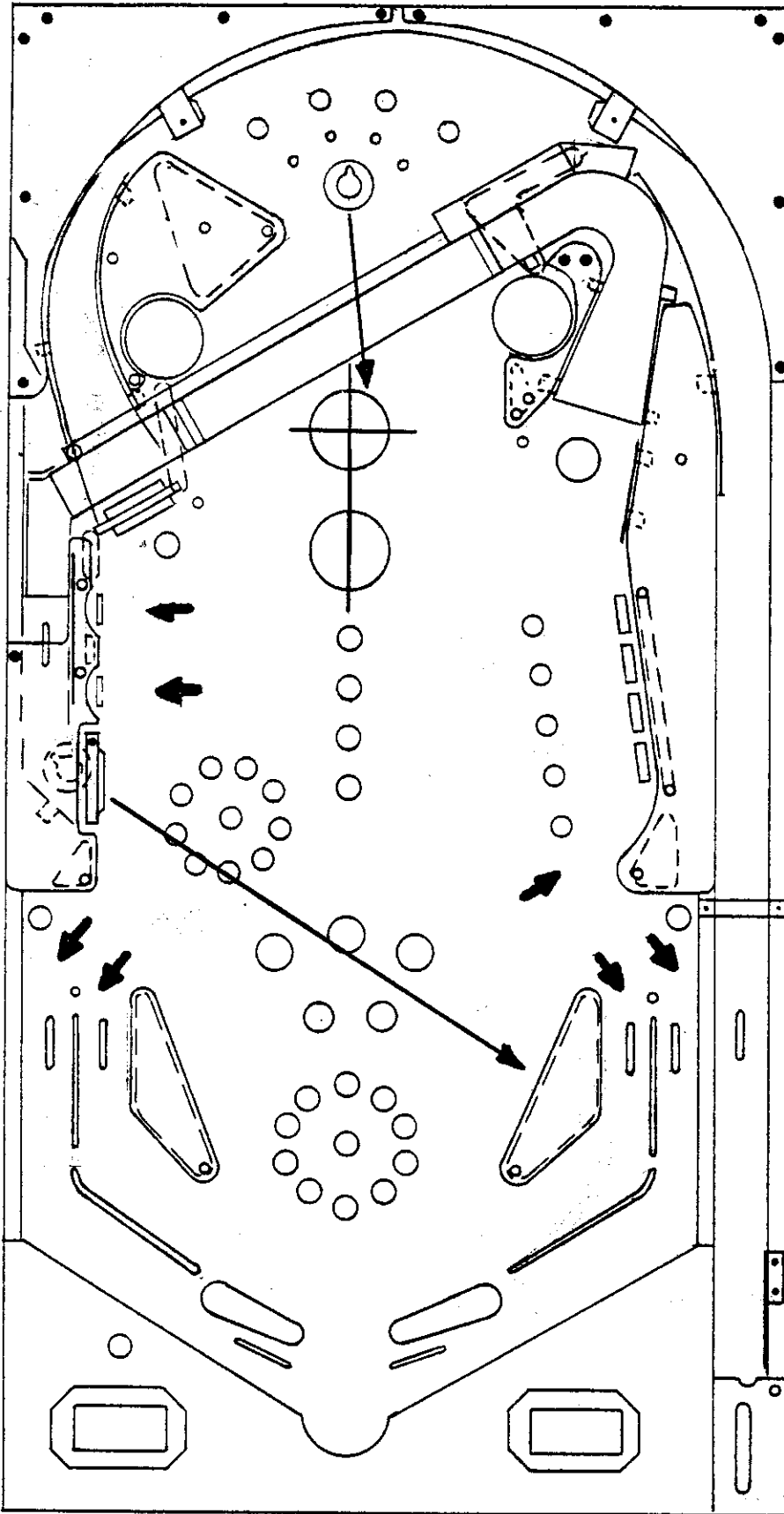

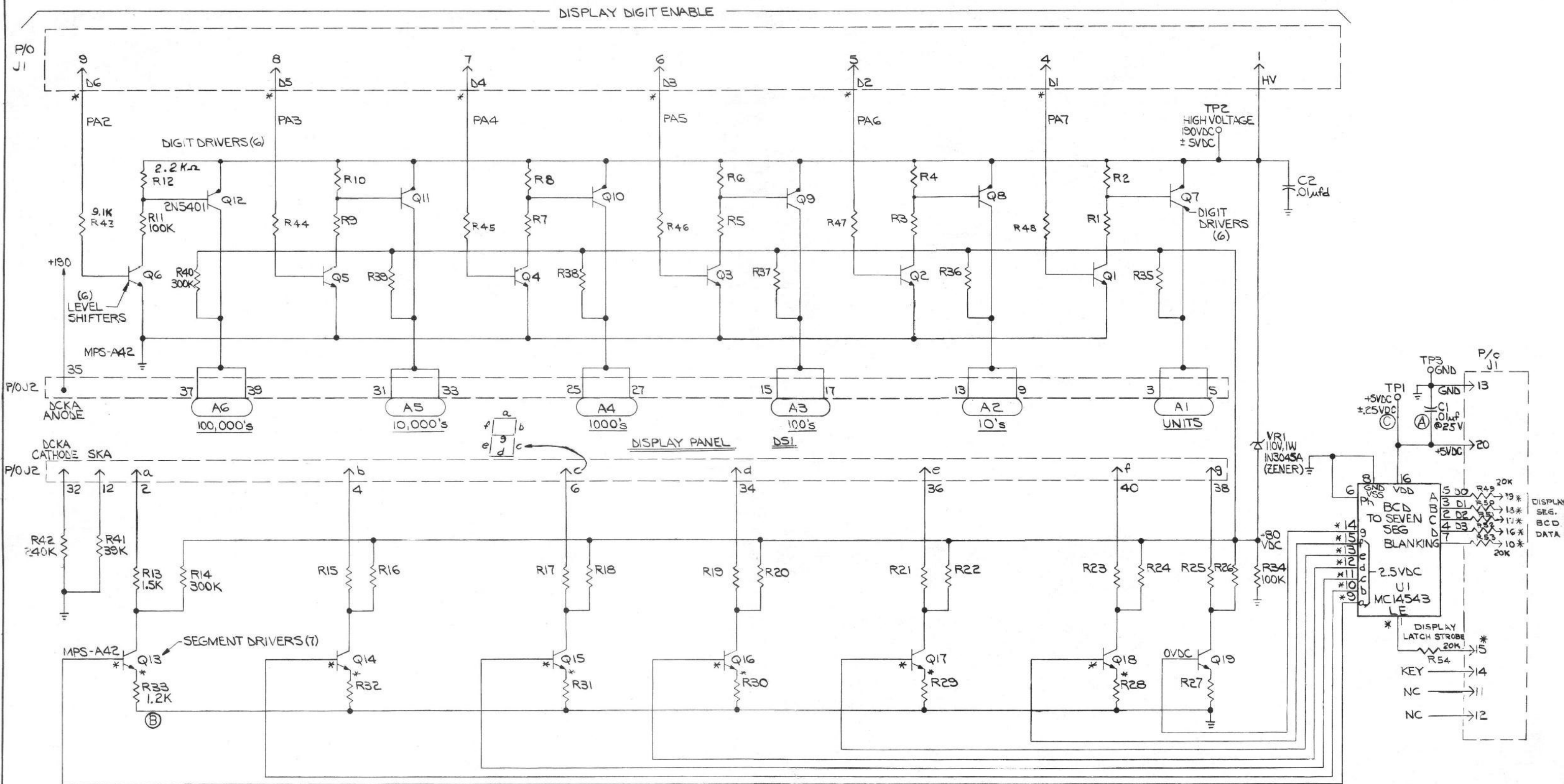

- NOTES:
1. UNLESS OTHERWISE SPECIFIED ALL RESISTORS ARE ±5%, 1/4W.
 2. PREFIX ALL REFERENCE DESIG. WITH ASSEMBLY REFERENCE DESIG. "A"
 3. * INDICATES 'AID' TEST POINT.

DIE SIZE — C.C. — FT. PER M — LBS. PER M —

ALL DESIGN, OPERATIVE AND PROCESS DATA PERTAINING TO THE ARTICLE SHOWN ON THIS SHEET IS THE PROPERTY OF BALLY MFG. CORP., CHICAGO, ILL. THIS INFORMATION IS DISCLOSED IN CONFIDENCE AND IS NOT TO BE COPIED, REPRODUCED, REVEALED TO OR APPROPRIATED BY OTHERS, IN PART OR IN WHOLE, WITHOUT THE EXPRESS CONSENT OF THE OWNERS. THE PRINT IS LOANED AND MUST NOT BE USED IN ANY MANNER DETRIMENTAL TO THE INTEREST OF THE OWNERS, AND MUST BE RETURNED ON DEMAND.

REMOVE ALL BURRS	DR. BY DATE	7-2-77
TOLERANCES ON DIMENSIONS UNLESS OTHERWISE SPECIFIED	CR. BY DATE	7-8-77
FRACTIONS ±	APP'D BY DATE	7-14-77
DECIMALS ±	FINISH	4/4/77
ANGLES ±	HARDENING	
DO NOT SCALE DRAWING		

Bally MANUFACTURING CORP. #1120-5
2640 BELMONT AVENUE
CHICAGO, ILLINOIS 60648
M. KEETICS

NAME: 6 DIGIT DISPLAY BOARD SCHEMATIC
ASSG. NO. USED ON: AS-2518-21
PART NO. W-1184-1c

OPER.	DEPT.	DESCRIPTION	TOOL No.

NO.	LET.	CHANGE	DATE	BY	CK.
3	C	WAS VAC	6-20-80	J.D.	
2	B	WAS 1K	3-28-80	J.D.	
1	A	WAS 500V	4-6-79	J.D.	

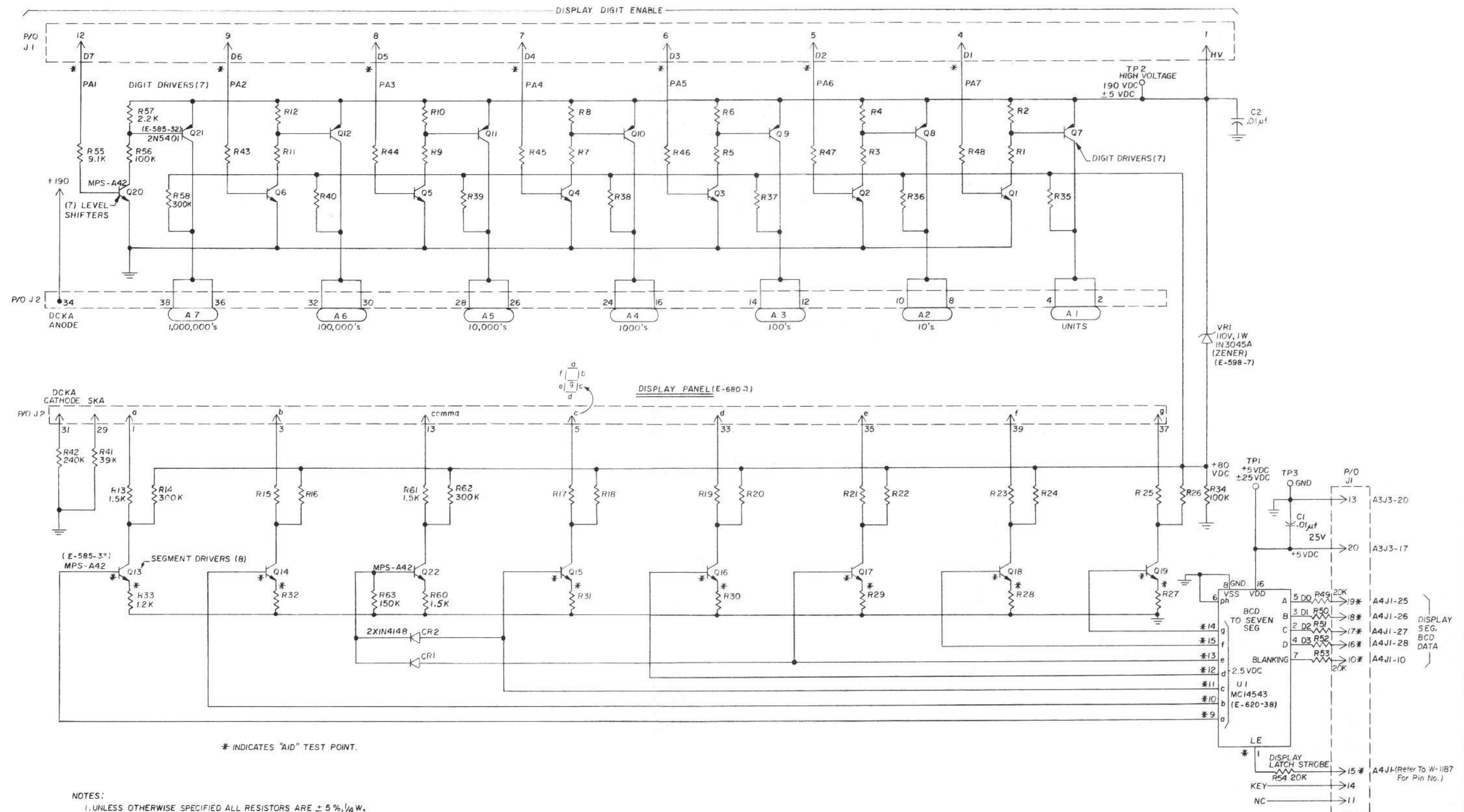

* INDICATES "Aid" TEST POINT.

- NOTES:
1. UNLESS OTHERWISE SPECIFIED ALL RESISTORS ARE $\pm 5\%$, $1/4$ W.
 2. PREFIX ALL REFERENCE DESIG. WITH ASSEMBLY REFERENCE DESIG. "A 1".

ALL DESIGN, OPERATIVE AND PROCESS DATA PERTAINING TO THE ARTICLE SHOWN ON THIS SHEET IS THE PROPERTY OF BALLY MFG. CORP. CHICAGO, ILL. THIS INFORMATION IS DISCLOSED IN CONFIDENCE AND IS NOT TO BE COPIED, REPRODUCED, REVEALED TO OR APPROPRIATED BY OTHERS IN PART OR IN WHOLE WITHOUT THE EXPRESS CONSENT OF THE OWNERS. THE PRINT IS LOANED AND MUST NOT BE USED IN ANY MANNER DETRIMENTAL TO THE INTEREST OF THE OWNERS AND MUST BE RETURNED ON DEMAND.

DR. BY FFC 6-18-0		DATE 6-18-0		Bally MANUFACTURING CORP. #1210	
CK. BY [Signature]		DATE 6-18-0		2640 BELMONT AVENUE CHICAGO, ILLINOIS	
AP'D BY [Signature]	DATE [Signature]	PRINT CONTROL	DIE SIZE	C.C.	FT. PER M.
AP'D BY [Signature]	DATE [Signature]	FINISH	NAME 7 DIGIT DISPLAY BOARD		
DO NOT SCALE DRAWING			ASSEM. NO. USED AS-2518-58		
HARDENING			MATERIAL		
CODE			PART NO. W-1184-2c		

OPER.	DEPT.	DESCRIPTION	TOOL NO.

NO.	LET.	CHANGE	DATE	BY

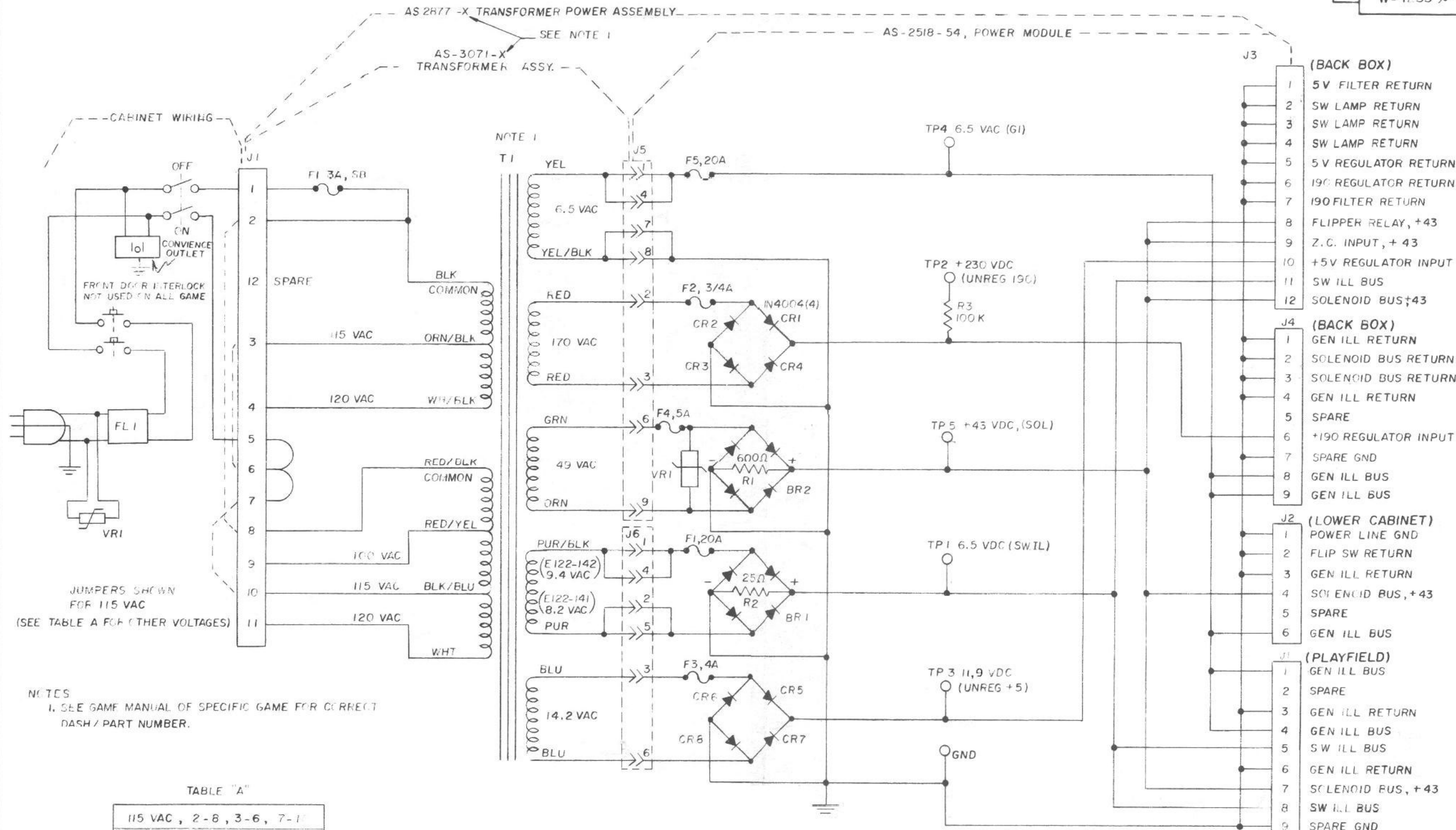

NOTES
1. SEE GAME MANUAL OF SPECIFIC GAME FOR CORRECT DASH / PART NUMBER.

TABLE "A"

115 VAC , 2-8 , 3-6 , 7-11
120 VAC , 2-8 , 4-6 , 7-11
220 VAC , 4-8 , 7-11
240 VAC , 4-8 , 7-11

ALL DESIGN, OPERATIVE AND PROCESS DATA PERTAINING TO THE ARTICLE SHOWN ON THIS SHEET IS THE PROPERTY OF BALLY MFG. CORP., CHICAGO, ILL. THIS INFORMATION IS DISCLOSED IN CONFIDENCE AND IS NOT TO BE COPIED, REPRODUCED, REVEALED TO OR APPROPRIATED BY OTHERS, IN PART OR IN WHOLE, WITHOUT THE EXPRESS CONSENT OF THE OWNERS. THE PRINT IS LOANED AND MUST NOT BE USED IN ANY MANNER DETRIMENTAL TO THE INTEREST OF THE OWNERS, AND MUST BE RETURNED ON DEMAND.

REMOVE ALL BURRS		DR. BY FFC	DATE 7-10-80	Bally MANUFACTURING CORP. 2640 BELMONT AVENUE CHICAGO, ILLINOIS # 1196	
TOLERANCES ON DIMENSIONS UNLESS OTHERWISE SPECIFIED		CK. BY AMCR	DATE 7-11-80		
FRACTIONS ± .008		AP'D BY	DATE	PRINT CONTROL	DIE SIZE
DECIMALS ± .003		AP'D BY	DATE		C.C.
EXCEPT HOLE DIA.'S		FINISH:		FT. PER M.	
ANGLES ± 1/2°		HARDENING:		LBS. PER M.	
DO NOT SCALE DRAWING				NAME POWER SUPPLY SCHEMATIC	
				ASSEM. NO. USED	
				PART NO. W-1233 <i>lb</i>	
				SCALE	

OPER.	DEPT.	DESCRIPTION	TOOL NO.
-------	-------	-------------	----------

NO.	LET.	CHANGE	DATE	BY
-----	------	--------	------	----

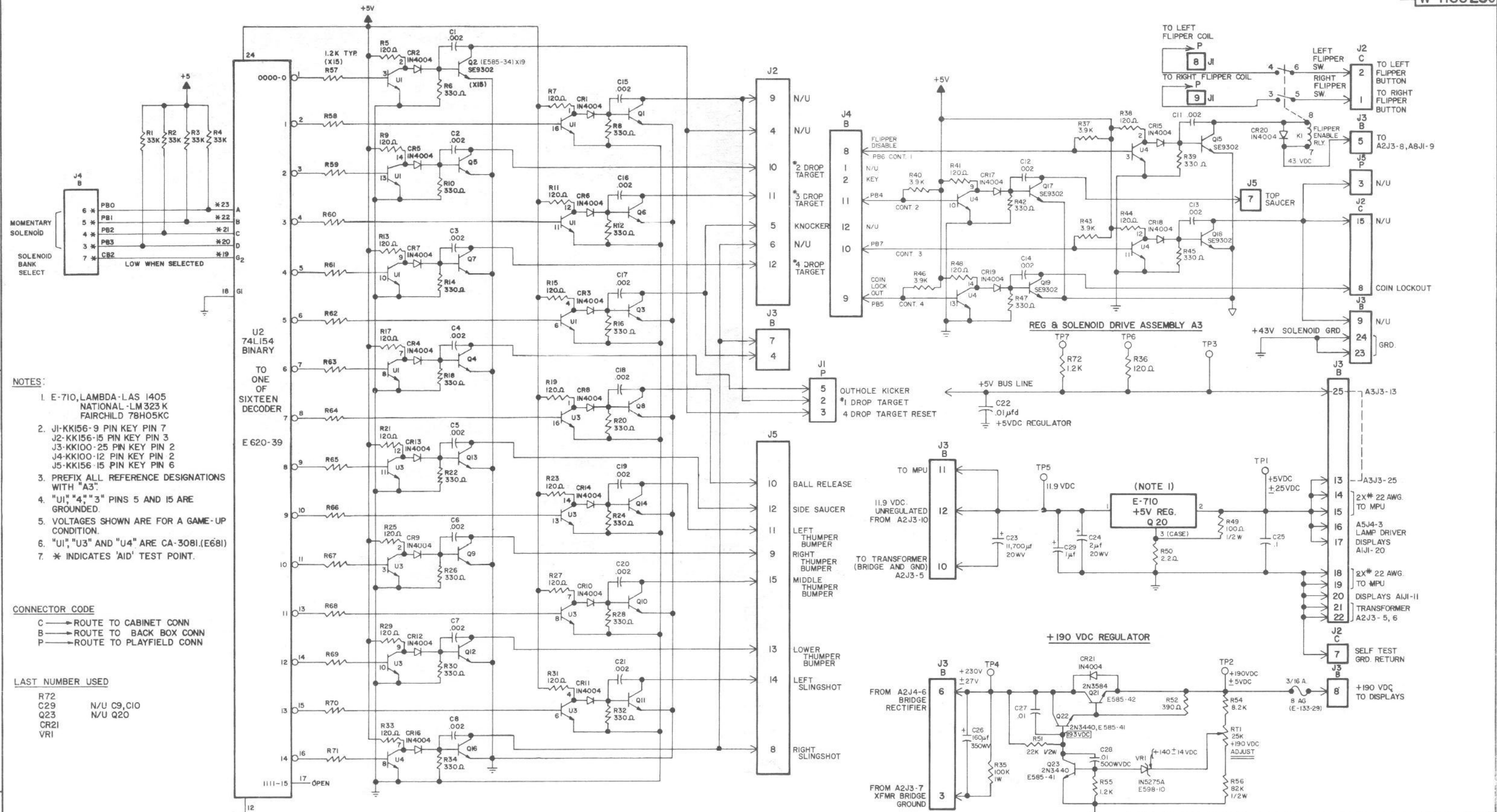

- NOTES:**
- E-710, LAMBDA-LAS 1405 NATIONAL-LM323 K FAIRCHILD 78H05KC
 - J1-KK156-9 PIN KEY PIN 7
J2-KK156-15 PIN KEY PIN 3
J3-KK100-25 PIN KEY PIN 2
J4-KK100-12 PIN KEY PIN 2
J5-KK156 15 PIN KEY PIN 6
 - PREFIX ALL REFERENCE DESIGNATIONS WITH "A3".
 - "U1", "U4", "U3" PINS 5 AND 15 ARE GROUNDED.
 - VOLTAGES SHOWN ARE FOR A GAME-UP CONDITION.
 - "U1", "U3" AND "U4" ARE CA-3081.(E681)
 - * INDICATES 'AID' TEST POINT.

CONNECTOR CODE

C → ROUTE TO CABINET CONN
 B → ROUTE TO BACK BOX CONN
 P → ROUTE TO PLAYFIELD CONN

LAST NUMBER USED

R72 N/U C9, C10
 Q23 N/U Q20
 CR21
 VRI

OPER.	DEPT.	DESCRIPTION	TOOL NO.

ALL DESIGN, OPERATIVE AND PROCESS DATA PERTAINING TO THE ARTICLE SHOWN ON THIS SHEET IS THE PROPERTY OF BALLY MFG. CORP. CHICAGO, ILL. THIS INFORMATION IS DISCLOSED IN CONFIDENCE AND IS NOT TO BE COPIED, REPRODUCED, REVEALED TO OR APPROPRIATED BY OTHERS IN PART OR IN WHOLE WITHOUT THE EXPRESS CONSENT OF THE OWNERS. THE PRINT IS LOANED AND MUST NOT BE USED IN ANY MANNER DETRIMENTAL TO THE INTEREST OF THE OWNERS, AND MUST BE RETURNED ON DEMAND.

REMOVE ALL BURRS		DR. BY: TKK	DATE: 9-9-85	Bally MANUFACTURING CORP. 2640 BELMONT AVENUE CHICAGO, ILLINOIS # 1196	
TOLERANCES ON DIMENSIONS UNLESS OTHERWISE SPECIFIED		CK. BY:	DATE:	PRINT CONTROL	SCALE
FRACTIONS - 1/32		AP'D BY: D	DATE: 9-26-85	DIE SIZE:	C.C. FT. PER M. LBS. PER M.
DECIMALS - 0.03		AP'D BY: [Signature]	DATE: 9-11-85	NAME:	ASSEM NO. USED
EXCEPT HOLE DIA'S		FINISH:		SOLENOID DRIVER VOLTAGE REGULATOR SCHEMATIC	
ANGLES - 1/2°		HARDENING:		MATERIAL: XENON	PART NO. W-1183-28c
DO NOT SCALE DRAWING					

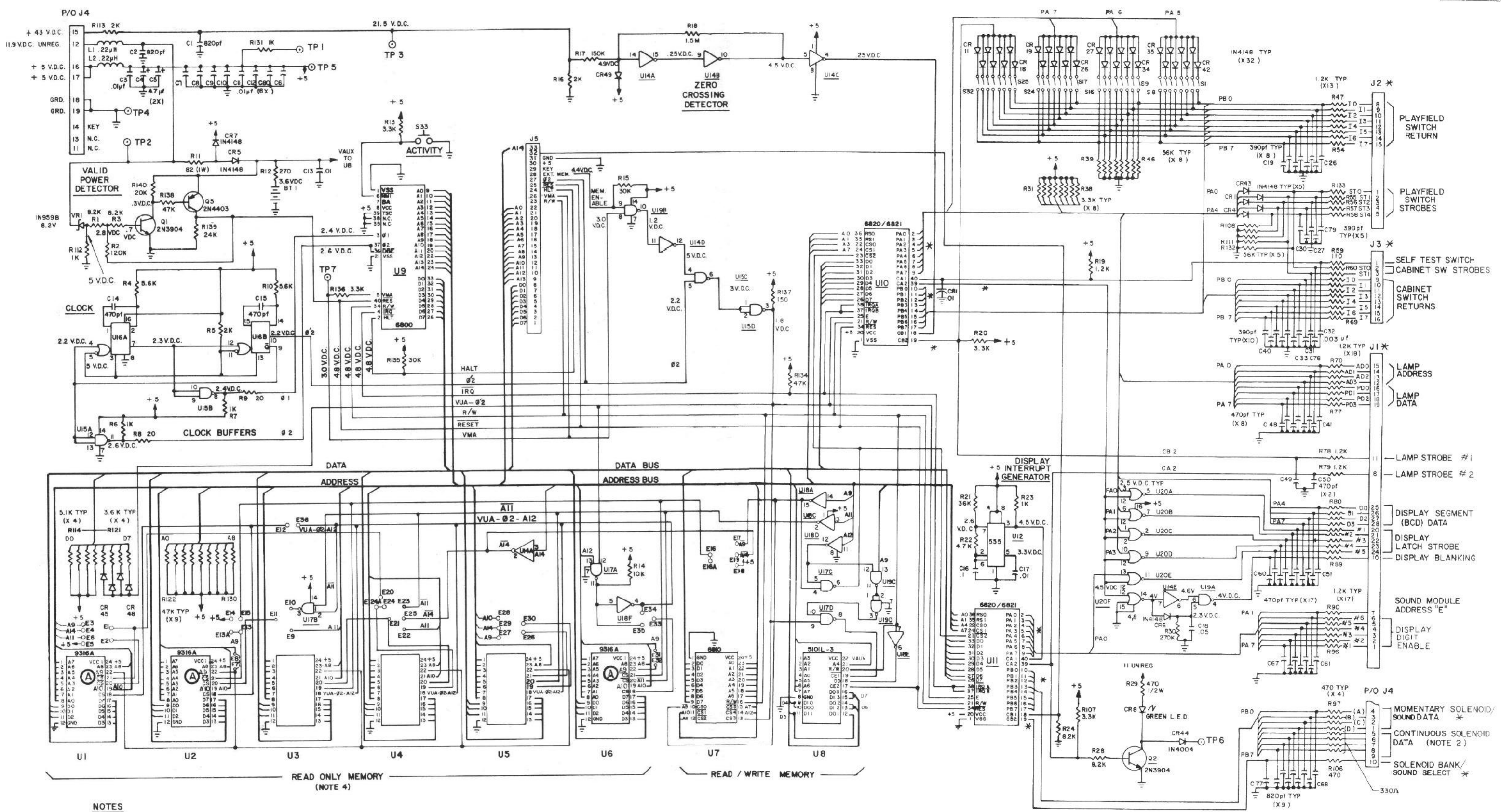

- NOTES**
- * INDICATES "AID" TEST POINT.
 - REMOVE A3J4 BEFORE USING AS AID TEST POINT
 - PREFIX ALL REFERENCE DESIGNATIONS WITH "A4"
 - EXACT CHIP COMPLEMENT USED IN SOCKETS U1 THRU U6 CAN VARY FOR DIFFERENT GAMES AND PRODUCTION LOTS. TABLES OF MEMORY CHIPS AND CORRESPONDING JUMPERS FOR DIFFERENT GAMES AVAILABLE FROM BALLY FIELD SERVICE DEPARTMENT.

REMOVE ALL BURRS		DR BY DATE		Bally MANUFACTURING CORP.	
TOLERANCES UNLESS OTHERWISE SPECIFIED FRACTIONS: 1/64 DECIMALS: .005 ANGLES: 1		EX BY DATE		2648 BELMONT AVENUE CHICAGO, ILLINOIS 60647	
DO NOT SCALE DRAWING		APP'D BY DATE		1119-E	
		FINISH		NAME M.P.U. CONTROL BOARD SCHEMATIC	
		HARDENING		MATERIAL	
		NO. LET. CHANGE		DATE BY CK	
				ASSEMBLY USED ON W	
				PART NO. W-1181-3c	

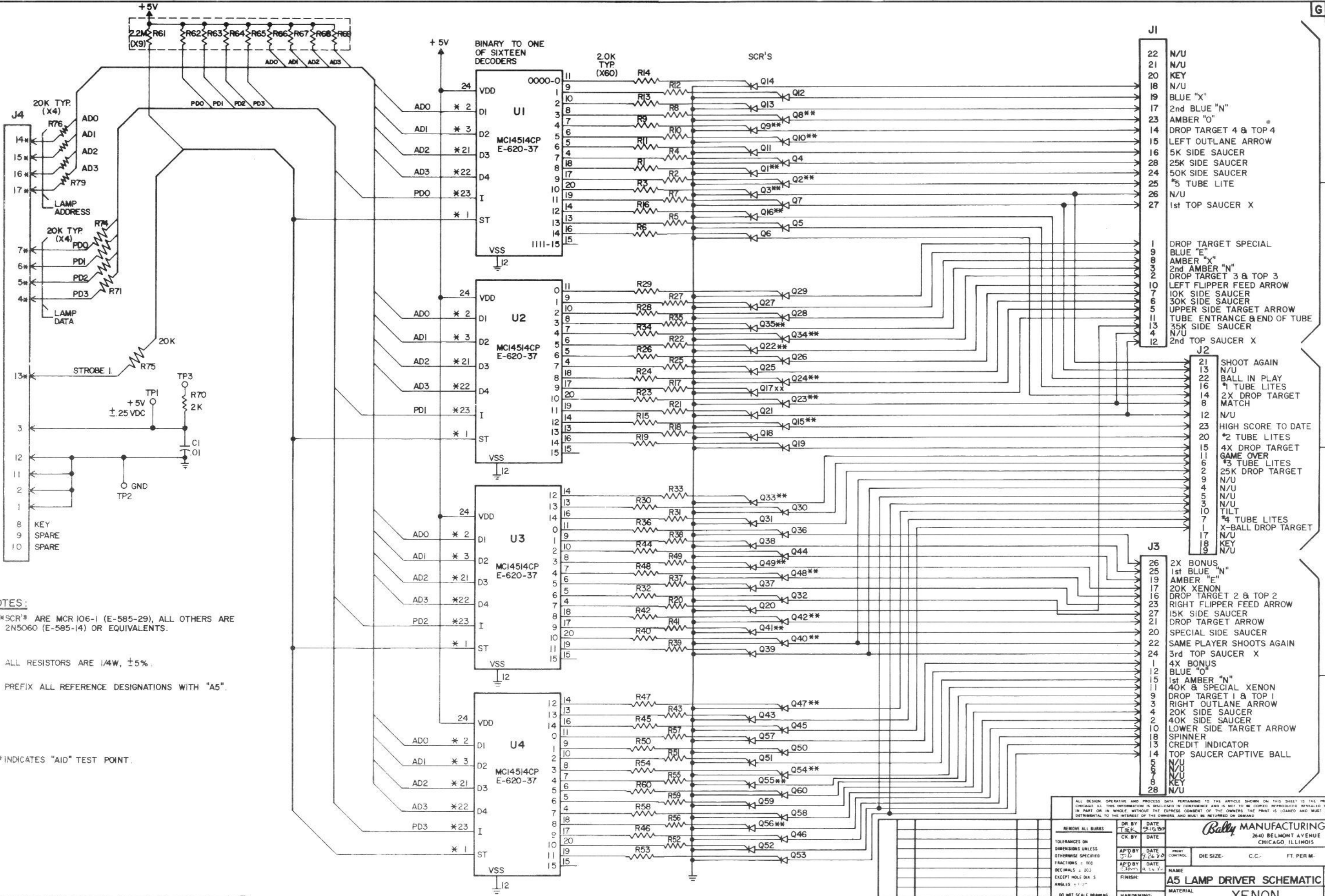

- NOTES:**
1. **SCR'S ARE MCR 106-1 (E-585-29), ALL OTHERS ARE 2N5060 (E-585-14) OR EQUIVALENTS.
 2. ALL RESISTORS ARE 1/4W, ±5%.
 3. PREFIX ALL REFERENCE DESIGNATIONS WITH "A5".
 4. *INDICATES "AID" TEST POINT.

ALL DESIGN OPERATIVE AND PROCESS DATA PERTAINING TO THE ARTICLE SHOWN ON THIS SHEET IS THE PROPERTY OF BALLY MANUFACTURING CORP. CHICAGO, ILL. THIS INFORMATION IS DISCLOSED IN CONFIDENCE AND IS NOT TO BE COPIED, REPRODUCED, REVEALED TO OR APPROPRIATED BY OTHERS IN ANY MANNER OR IN WHOLE, WITHOUT THE EXPRESS CONSENT OF THE OWNERS. THE PRINT IS LOANED AND MUST NOT BE USED IN ANY MANNER DETRIMENTAL TO THE INTEREST OF THE OWNERS AND MUST BE RETURNED ON DEMAND.

DR BY	DATE	DR BY	DATE
TSK	9-15-80	TSK	7-26-79
CK BY	DATE	CK BY	DATE
AP'D BY	DATE	AP'D BY	DATE
AP'D BY	DATE	AP'D BY	DATE
FINISH:		FINISH:	
HARDENING:		HARDENING:	

Bally MANUFACTURING CORP.
2640 BELMONT AVENUE # 1196
CHICAGO, ILLINOIS

A5 LAMP DRIVER SCHEMATIC

MATERIAL: **XENON**

ASSEM. NO. USED: [] SCAI: []

PART NO. **W-1182-27**

NO.	LET.	CHANGE	DATE	BY

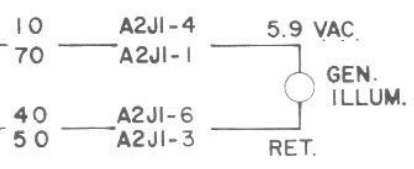
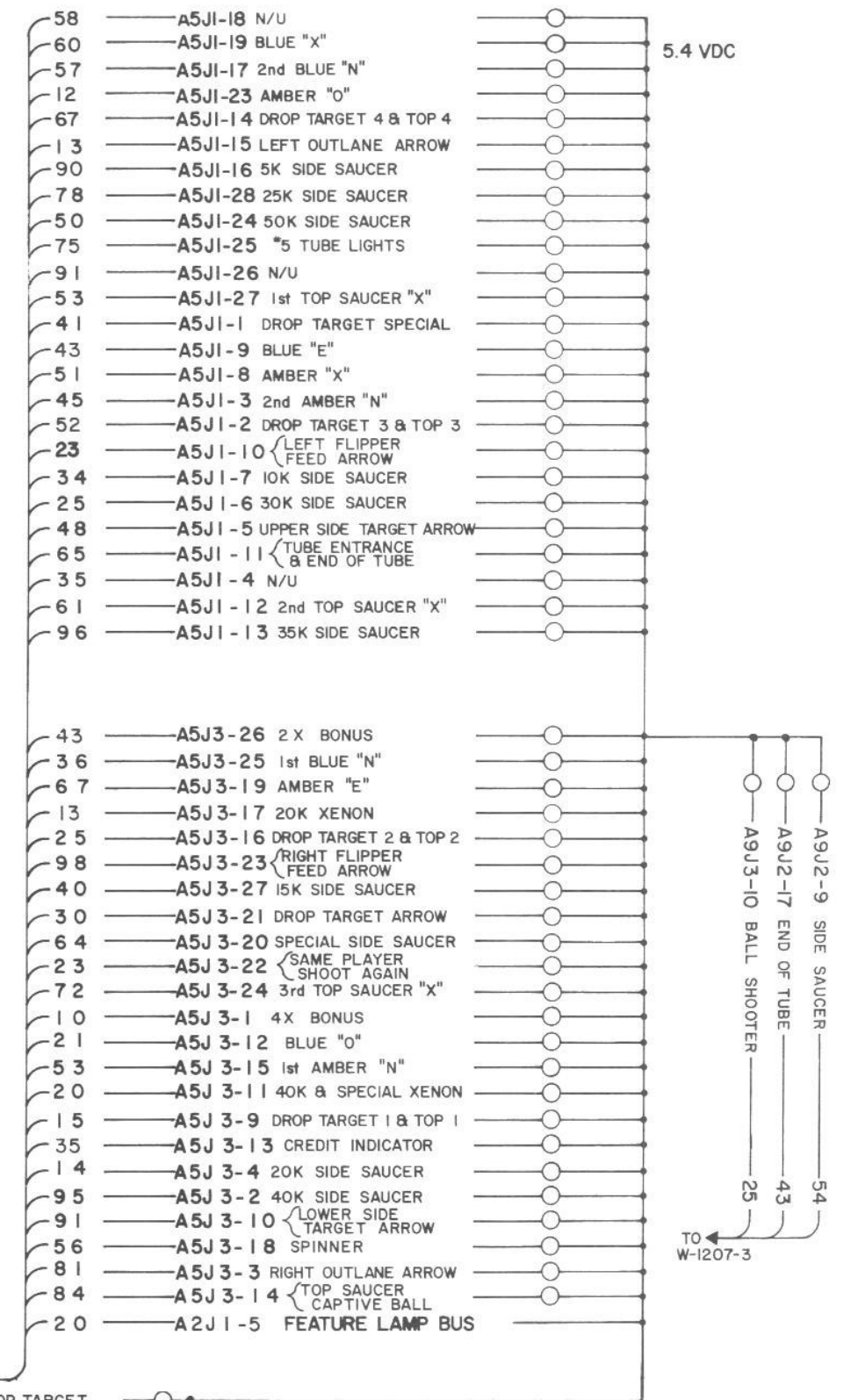
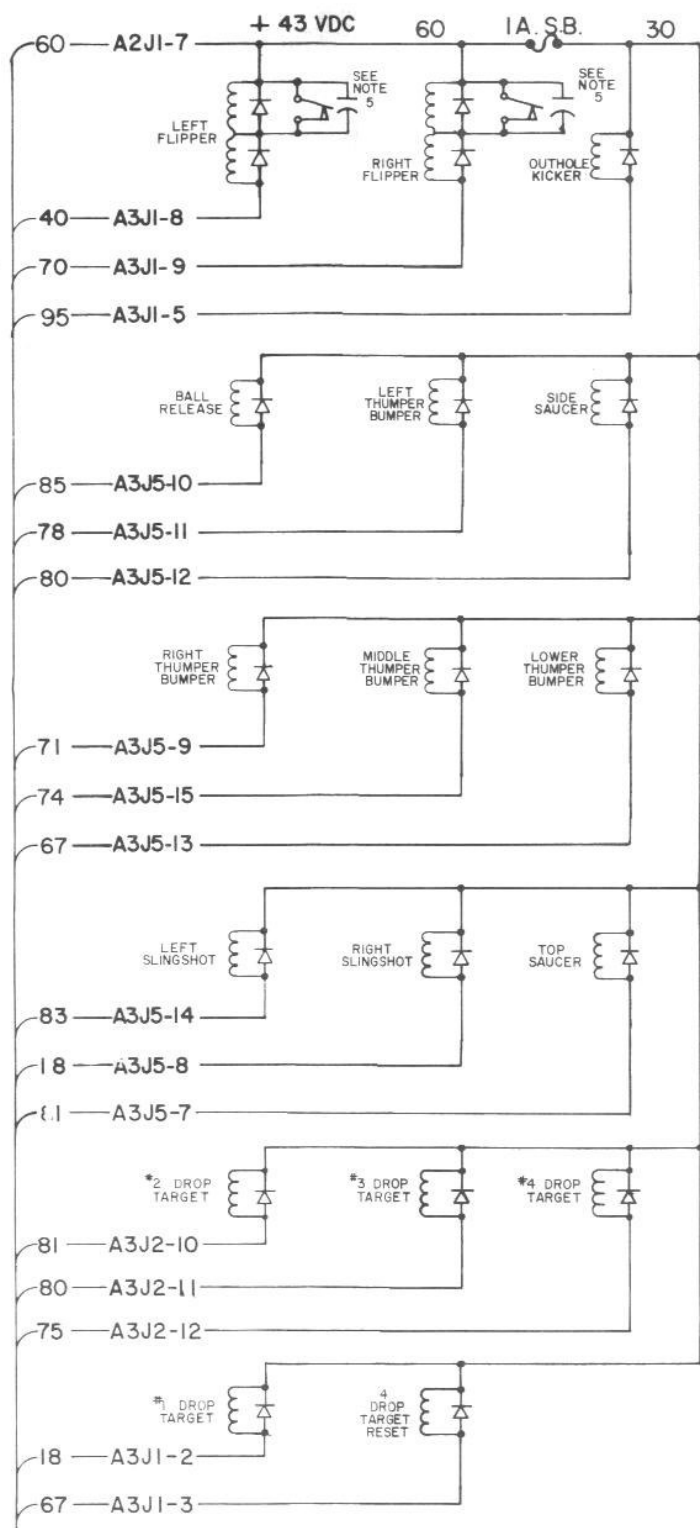
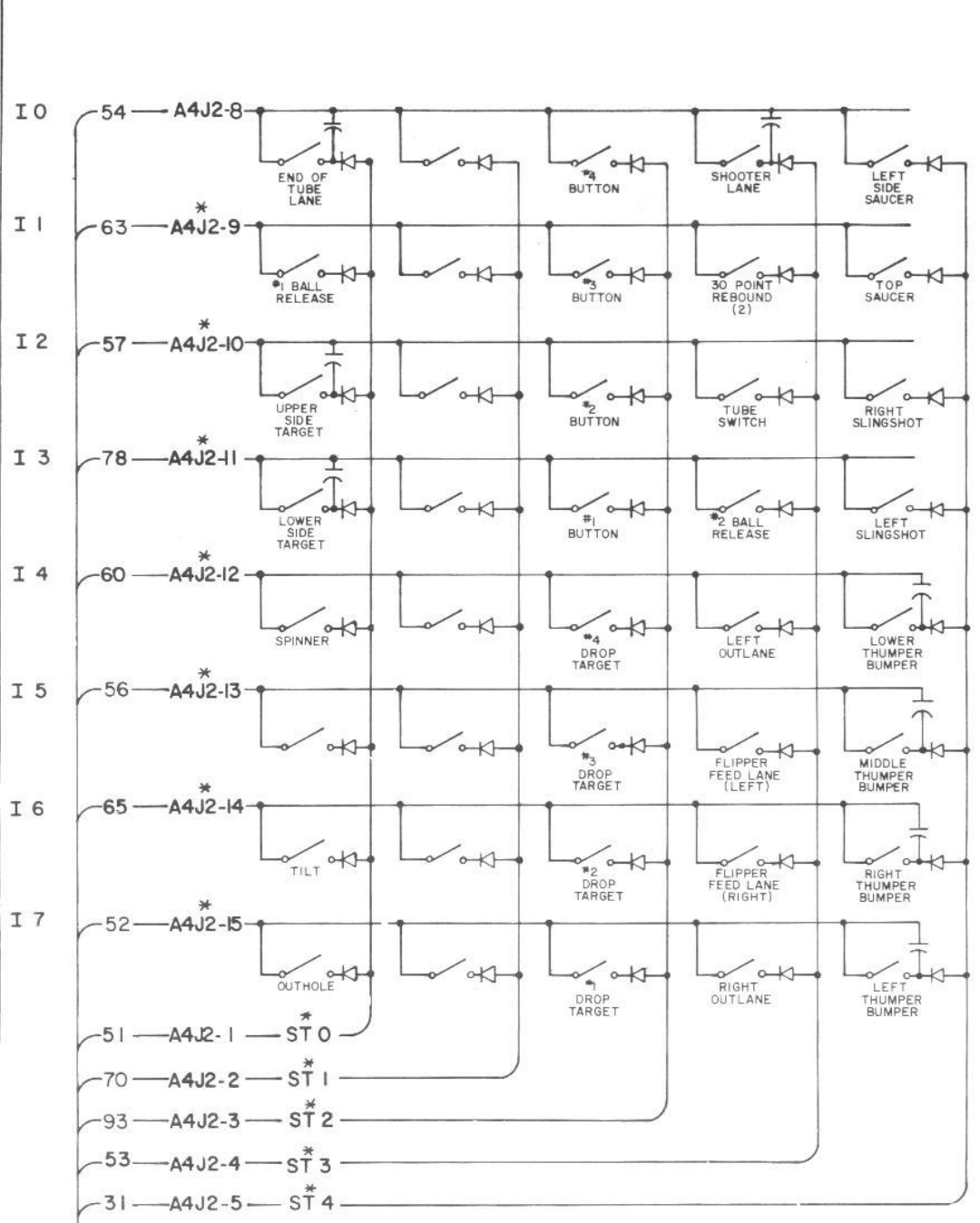

NOTES

- INDICATES NOT USED
- N/U = NOT USED ON PLAYFIELD
- * INDICATES AID TEST POINT
- COIL DIODES ARE IN4004, (E-587-6), SWITCH DIODES ARE IN 4148, (E-587-14)
ALL CAPACITORS ARE .05 MFD. (E-586-80)
- GERMANY ONLY=CAPACITOR .01 MFD @ 500 V. (E-586-65)

PLAYFIELD A6

- 20 A5J2-2 25K DROP TARGET
- 12 A5J2-14 2X DROP TARGET
- 23 A5J2-15 4X DROP TARGET
- 34 A5J2-16 *1 TUBE LITES
- 98 A5J2-20 *2 TUBE LITES
- 85 A5J2-6 *3 TUBE LITES
- 91 A5J2-7 *4 TUBE LITES
- 60 A5J2-1 X-BALL DROP TARGETS

ALL DESIGN, OPERATIVE AND PROCESS DATA PERTAINING TO THE ARTICLE SHOWN ON THIS SHEET IS THE PROPERTY OF BALLY MFG. CORP. CHICAGO, ILL. THIS INFORMATION IS DISCLOSED IN CONFIDENCE AND IS NOT TO BE COPIED, REPRODUCED, REVEALED TO OR APPROPRIATED BY OTHERS, IN PART OR IN WHOLE, WITHOUT THE EXPRESS CONSENT OF THE OWNERS. THE PRINT IS LOANED AND MUST NOT BE USED IN ANY MANNER DETRIMENTAL TO THE INTEREST OF THE OWNERS, AND MUST BE RETURNED ON DEMAND.

REMOVE ALL BURRS		DR. BY DATE 9-16-50		Bally MANUFACTURING CORP. 2640 BELMONT AVENUE CHICAGO, ILLINOIS 1196	
TOLERANCES UNLESS OTHERWISE SPECIFIED FRACTIONS - 1/64 DECIMALS - .005 ANGLES - °		APPROVED BY DATE 9-26-50		CONTRACT NO. TOTAL SCALE	
DO NOT SCALE DRAWING		FINISH: 9-30-50		NAME: SWITCH MATRIX	
LET. CHANGE DATE BY CK.		HARDENING:		MATERIAL: XENON	
				ASSEMBLY NO. USED ON W-1192-24c	

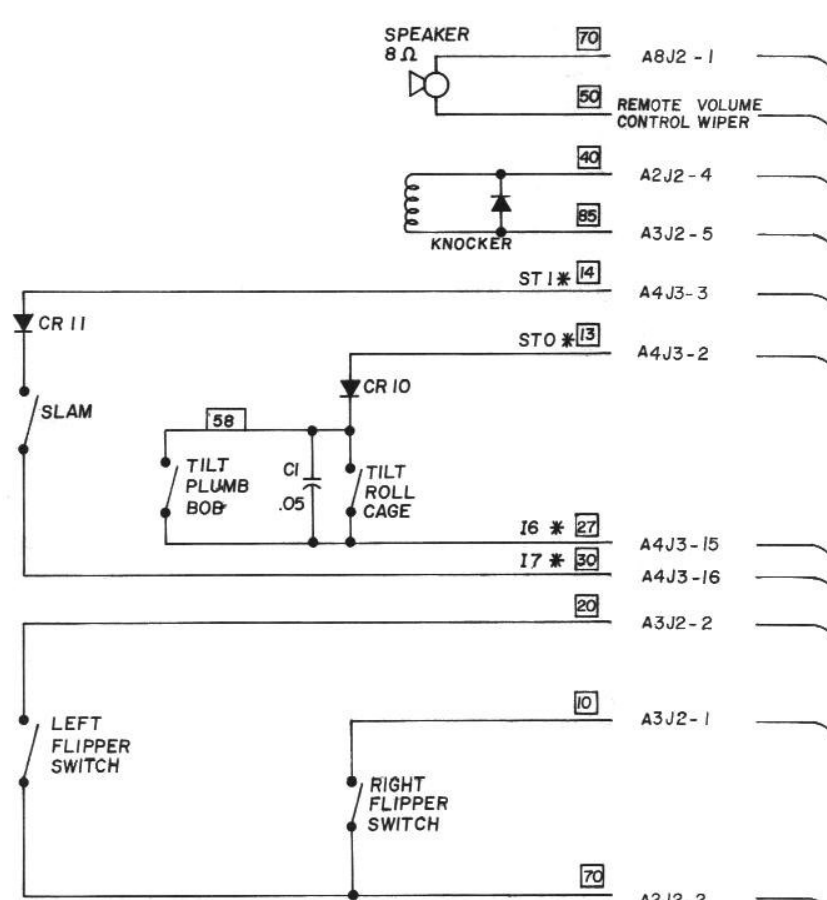
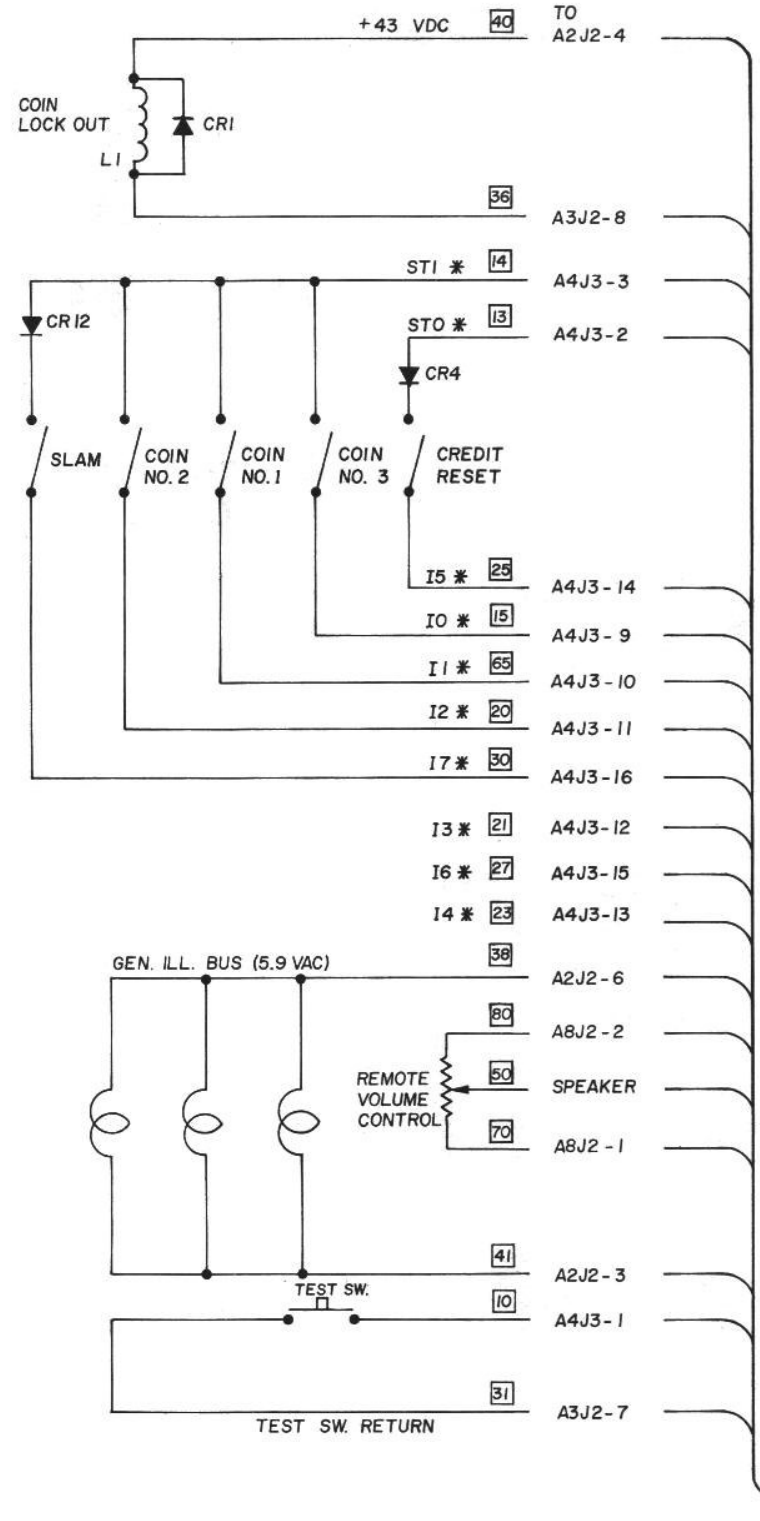

- NOTES: (CAUTION)
1. USE BALLY PART NO. E-713 FOR 115-120 VAC.
 2. USE BALLY PART NO. E-713-1 FOR 220-240 VAC.
 3. * INDICATES AID TEST POINT.

TO	J1 PIN	TO	J1 PIN
A4J3-9	1	A4J3-3	11
A4J3-10	2	A2J2-4	15
A4J3-11	3	A3J2-8	16
A4J3-12	4	A2J2-6	17
A4J3-13	5	A2J2-3	18
A4J3-14	6	A4J3-1	19
A4J3-15	7	A3J2-7	20
A4J3-16	8	SPEAKER	9
A4J3-2	10	A8J2-1	12
DOOR PLUG		A8J2-2	13

A7 CABINET ASS'Y. WIRING
NOTE: DIODES ARE IN4004 (E-587-6)

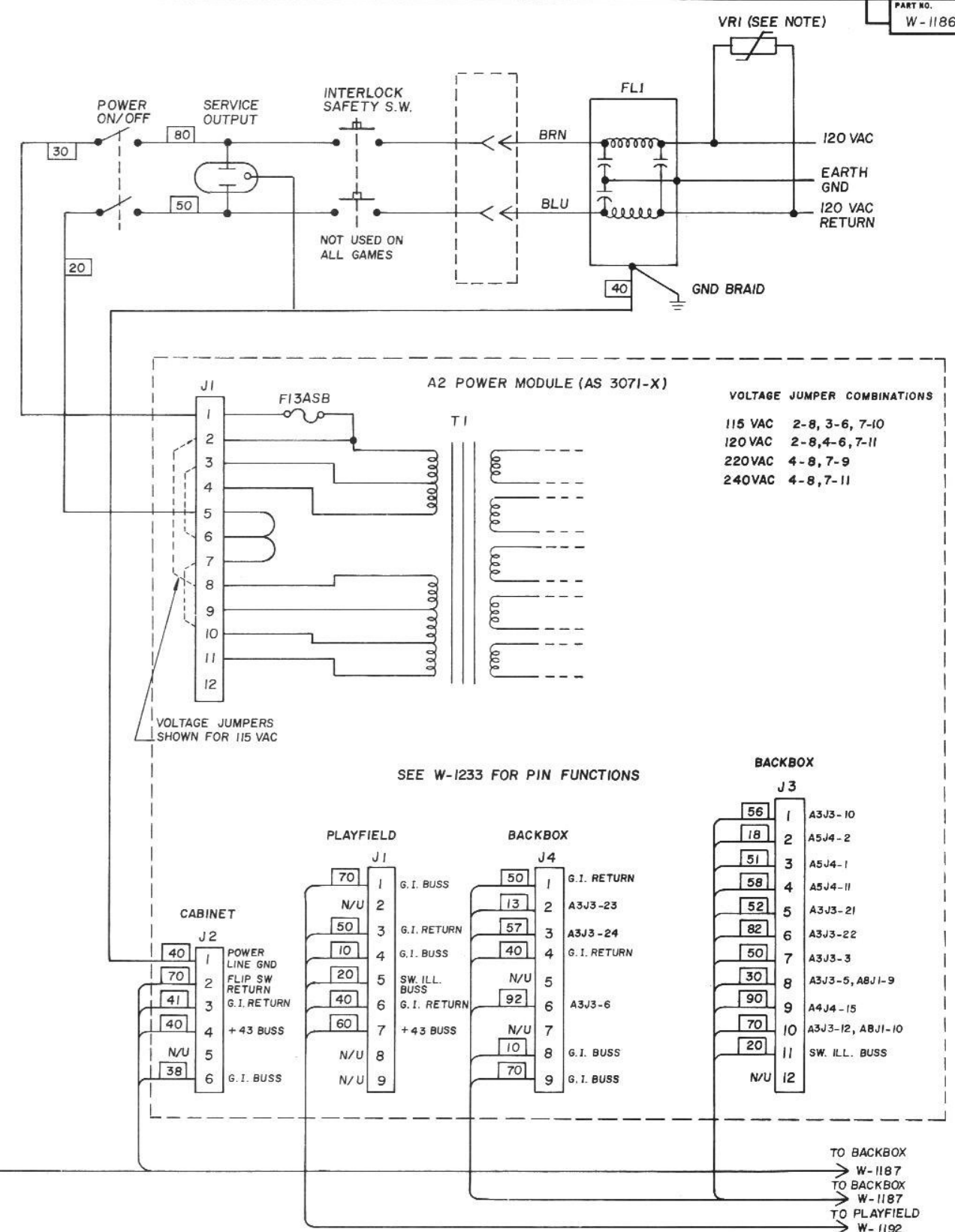

VOLTAGE JUMPER COMBINATIONS

115 VAC	2-8, 3-6, 7-10
120 VAC	2-8, 4-6, 7-11
220 VAC	4-8, 7-9
240 VAC	4-8, 7-11

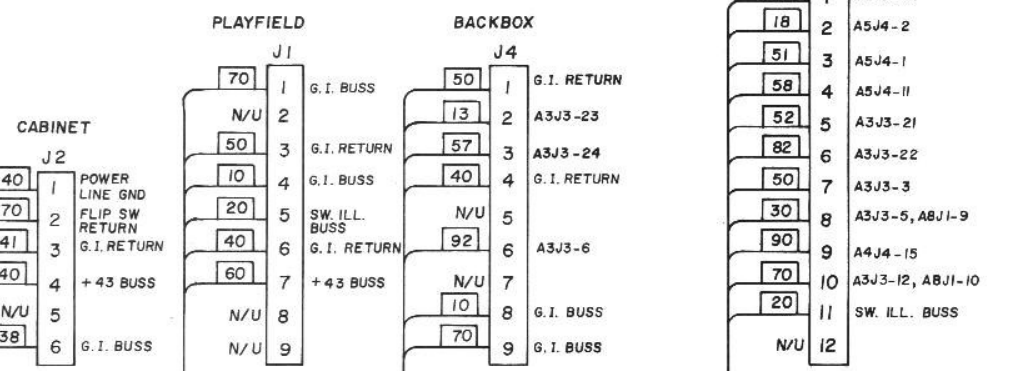

TO BACKBOX
W-1187
TO BACKBOX
W-1187
TO PLAYFIELD
W-1192

OPER.	DEPT.	DESCRIPTION	TOOL NO.

NO.	LET.	CHANGE	DATE	BY

REMOVE ALL BURRS

TOLERANCES ON DIMENSIONS UNLESS OTHERWISE SPECIFIED: FRACTIONS = 0/100, DECIMALS = 0.03, EXCEPT HOLE DIA. S, ANGLES = 1/2"

DO NOT SCALE DRAWING

OR BY DATE: FFC 9-28-80

CK BY DATE: AMCR 9-29-80

AP'D BY DATE: PRINT CONTROL

AP'D BY DATE: NAME

FINISH: MATERIAL

HARDENING: CODE

Bally MANUFACTURING CORP. 2640 BELMONT AVENUE CHICAGO, ILLINOIS # 1196

ASSEM. NO. USED: WIRING DIAGRAM ELECTRONIC

PART NO. W-1186-9 c

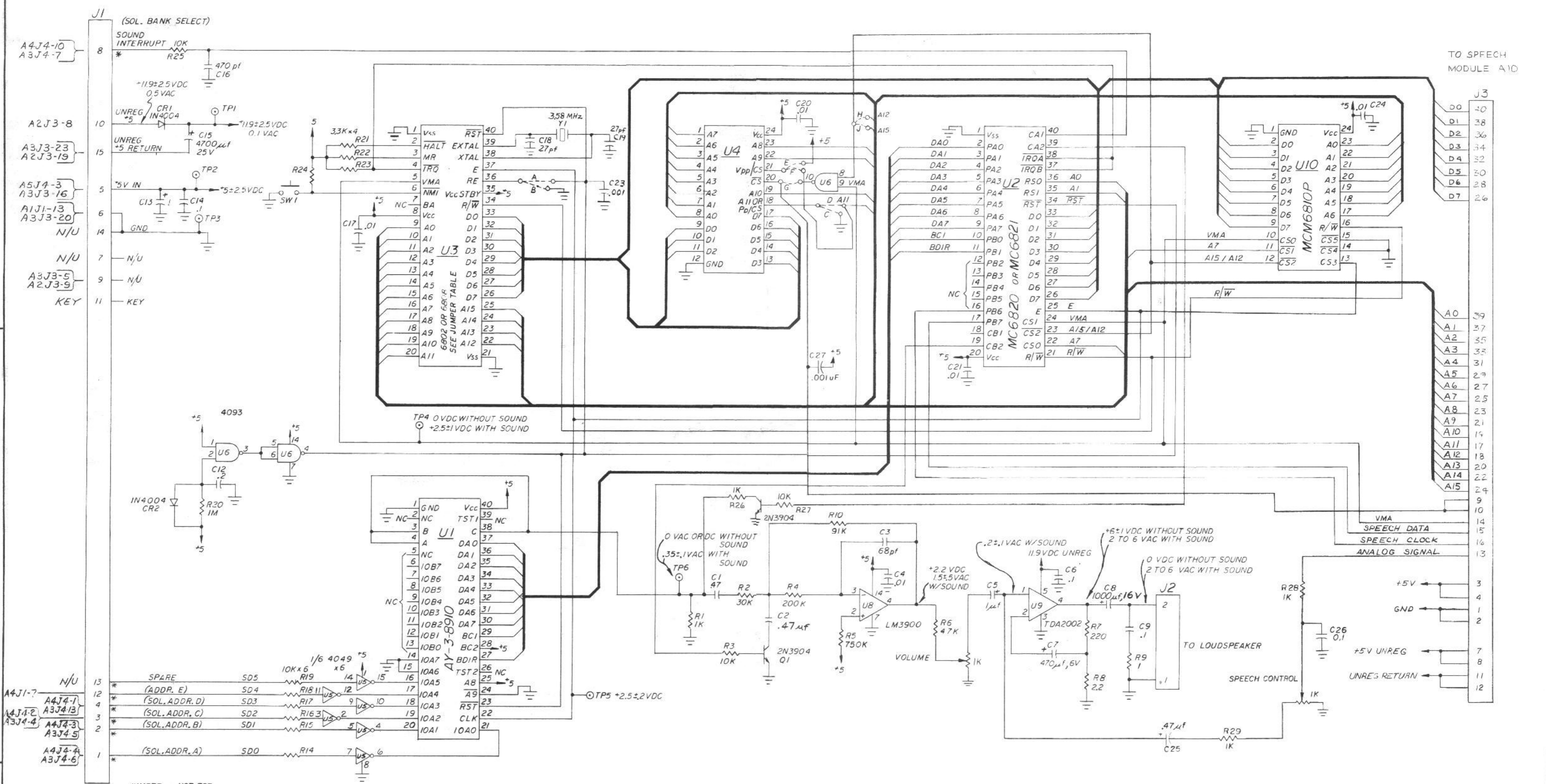

JUMPER USE FOR...

A	6802 (WITHOUT 6810 UIO)
B	6808 (WITH 6810 UIO)
C	2K X 8 ROM OR EPROM OR 4K X 8 INTEL 2732 EPROM
D	4K X 8 ROM OR 4K X 8 TI. 2532 EPROM
E	2K X 8 ROM OR EPROM OR 4K X 8 ROM OR 4K X 8 TI. 2532 EPROM
F	4K X 8 INTEL 2732 EPROM
G	SOUNDS PLUS BOARDS USED WITHOUT VOCALIZER OPTION (REMOVE C27)
H	REPLACEMENT OF AS-2518-B1 SOUND MODULE
J	VOCALIZER-MODULE-PROGRAMMED U4

NOTES:

- UNLESS OTHERWISE INDICATED, ALL RESISTOR VALUES ARE IN OHMS, ALL CAPACITOR VALUES ARE IN MMFD'S.
- PREFIX ALL REFERENCE DESIGNATIONS WITH A8.
- *INDICATES 'AID' TEST POINT.

ALL DESIGN, OPERATIVE AND PROCESS DATA PERTAINING TO THE ARTICLE SHOWN ON THIS SHEET IS THE PROPERTY OF BALLY MFG. CORP. CHICAGO. ALL THIS INFORMATION IS DISCLOSED IN CONFIDENCE AND IS NOT TO BE COPIED, REPRODUCED, REVEALED TO OR APPROPRIATED BY OTHERS, IN PART OR IN WHOLE, WITHOUT THE EXPRESS CONSENT OF THE OWNERS. THE PRINT IS LOANED AND MUST NOT BE USED IN ANY MANNER DETRIMENTAL TO THE INTEREST OF THE OWNERS AND MUST BE RETURNED ON DEMAND.

Bally MANUFACTURING CORP. 2640 BELMONT AVENUE CHICAGO, ILLINOIS 60648

DR. BY: EFC DATE: 5-19-68
 CR. BY: AMCF DATE: 6-20-69
 AP'D BY: DATE: 7/28/69
 FINISH: 8-27-69

REMOVE ALL BURRS
 TOLERANCES ON DIMENSIONS UNLESS OTHERWISE SPECIFIED
 FRACTIONS = 1/32
 DECIMALS = .003
 EXCEPT HOLE DIA'S ANGLES = 1/2"

NAME: SOUNDS PLUS MODULE A8 SCHEMATIC
 ASSEM. NO. USED: AS-2518-56
 PART NO.: W-1211-1c

OPER.	DEPT.	DESCRIPTION	TOOL NO.

NO.	LET.	CHANGE	DATE	BY

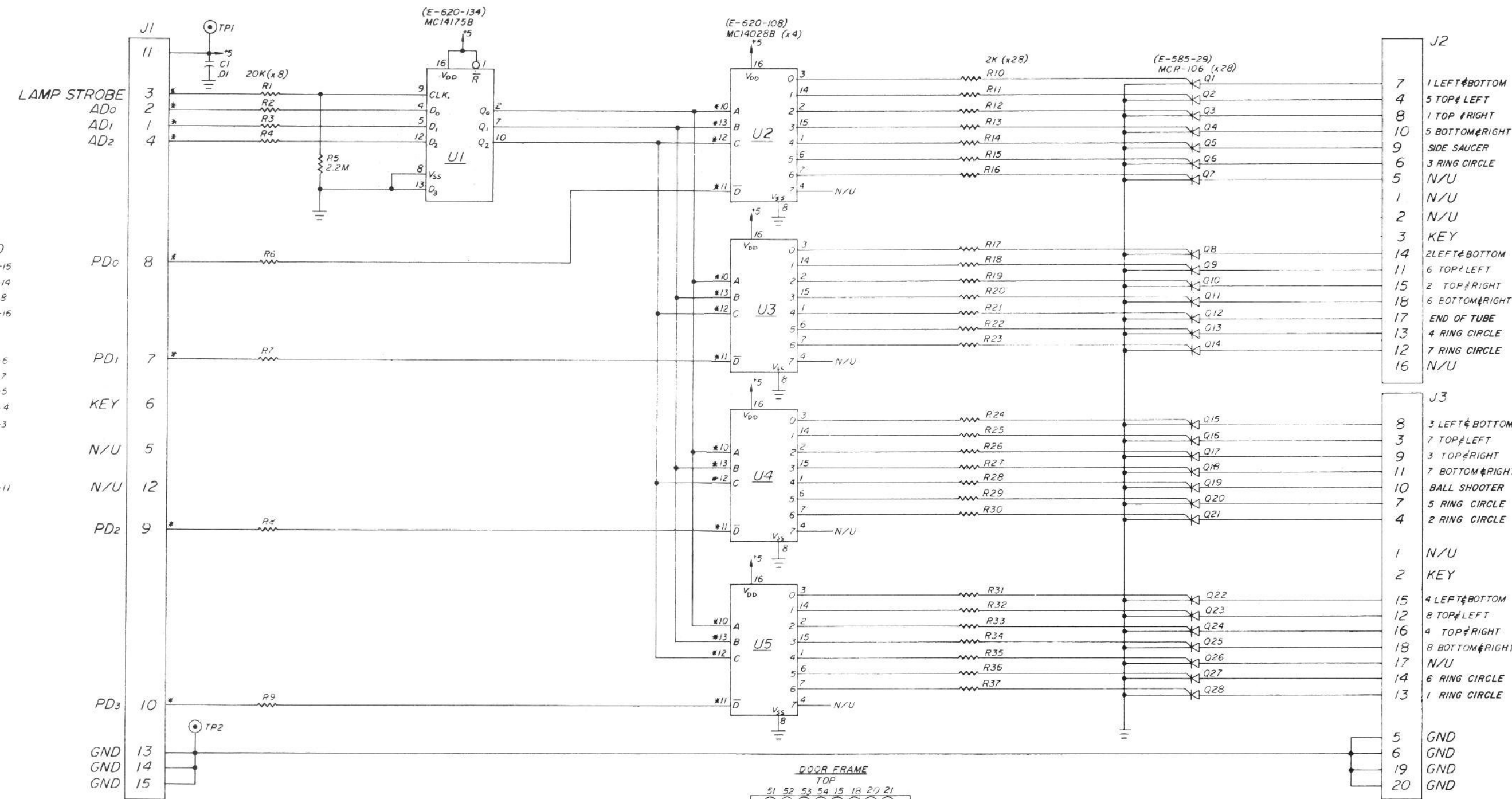

A9 J1 TO

13	1	A5J4-15
32	2	A5J4-14
90	3	A4J1-9
45	4	A5J4-16
	5	
65	7	A5J4-6
63	8	A5J4-7
71	9	A5J4-5
74	10	A5J4-4
84	11	A5J4-3
	12	
	13	
	14	
58	15	A5J4-11

TO W-1187-24c

- J1
- 11
 - 3 LAMP STROBE
 - 2 AD₀
 - 1 AD₁
 - 4 AD₂
 - 8 PD₀
 - 7 PD₁
 - 6 KEY
 - 5 N/U
 - 12 N/U
 - 9 PD₂
 - 10 PD₃
 - 13 GND
 - 14 GND
 - 15 GND

- J2
- 7 1 LEFT BOTTOM
 - 4 5 TOP LEFT
 - 8 1 TOP RIGHT
 - 10 5 BOTTOM RIGHT
 - 9 SIDE SAUCER
 - 6 3 RING CIRCLE
 - 5 N/U
 - 1 N/U
 - 2 N/U
 - 3 KEY
 - 14 2 LEFT BOTTOM
 - 11 6 TOP LEFT
 - 15 2 TOP RIGHT
 - 18 6 BOTTOM RIGHT
 - 17 END OF TUBE
 - 13 4 RING CIRCLE
 - 12 7 RING CIRCLE
 - 16 N/U
- J3
- 8 3 LEFT BOTTOM
 - 3 7 TOP LEFT
 - 9 3 TOP RIGHT
 - 11 7 BOTTOM RIGHT
 - 10 BALL SHOOTER
 - 7 5 RING CIRCLE
 - 4 2 RING CIRCLE
 - 1 N/U
 - 2 KEY
 - 15 4 LEFT BOTTOM
 - 12 8 TOP LEFT
 - 16 4 TOP RIGHT
 - 18 8 BOTTOM RIGHT
 - 17 N/U
 - 14 6 RING CIRCLE
 - 13 1 RING CIRCLE
 - 5 GND
 - 6 GND
 - 19 GND
 - 20 GND

- A9 J2
- 1 N/U
 - 2 N/U
 - 3 KEY
 - 4 15
 - 5 N/U
 - 6 80
 - 7 10
 - 8 51
 - 9 54
 - 10 56
 - 11 18
 - 12 85
 - 13 81
 - 14 12
 - 15 52
 - 16 N/U
 - 17 43
 - 18 57
- A9 J3
- 1 N/U
 - 2 KEY
 - 3 20
 - 4 78
 - 5 N/U
 - 6 N/U
 - 7 82
 - 8 13
 - 9 53
 - 10 25
 - 11 58
 - 12 21
 - 13 60
 - 14 83
 - 15 14
 - 16 54
 - 17 N/U
 - 18 72
 - 19 N/U
 - 20 N/U

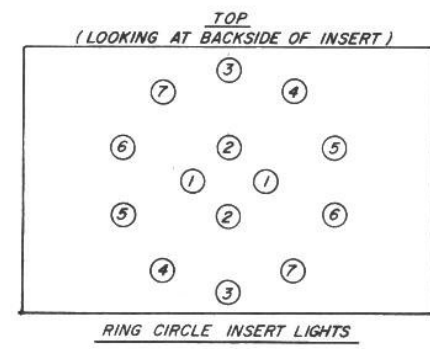

NOTES:
 1. ALL RESISTORS ARE 1/4W, 5%.
 2. VOLTAGES SHOWN ARE FOR GAME UP CONDITIONS.
 3. * INDICATES "AID" TEST POINT.
 4. SCR'S ARE MCR-106-1, (E-585-29).
 5. PREFIX ALL REFERENCE DESIGNATIONS WITH "A9".

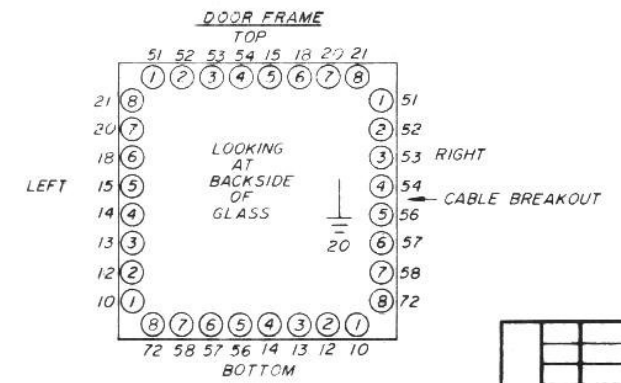

ALL DESIGN, OPERATIVE AND PROCESS DATA PERTAINING TO THE ARTICLE SHOWN ON THIS SHEET IS THE PROPERTY OF BALLY MANUFACTURING CORP. CHICAGO, ILL. THIS INFORMATION IS DISCLOSED IN CONFIDENCE AND IS NOT TO BE COPIED, REPRODUCED, REVEALED TO OR APPROPRIATED BY OTHERS, IN PART OR IN WHOLE, WITHOUT THE EXPRESS CONSENT OF THE OWNERS. THE PRINT IS LOANED AND MUST NOT BE USED IN ANY MANNER DETRIMENTAL TO THE INTEREST OF THE OWNERS, AND MUST BE RETURNED ON DEMAND.

REMOVE ALL BURRS

TOLERANCES UNLESS OTHERWISE SPECIFIED: FRACTIONS ± .004 DECIMALS ± .003 EXCEPT HOLE DIA. & ANGLES ± .127

DO NOT SCALE DRAWING

DR BY DATE 9-11-80
 CK BY DATE
 AP'D BY DATE
 MOD BY DATE 9-15-80
 FINISH:

AUXILIARY LAMP DRIVER "A9"

MATERIAL XENON

ASSEM. NO. USED SCALE
 PART NO. W-1207-3

OPER.	DEPT.	DESCRIPTION	TOOL NO.

NO.	LET.	CHANGE	DATE	BY

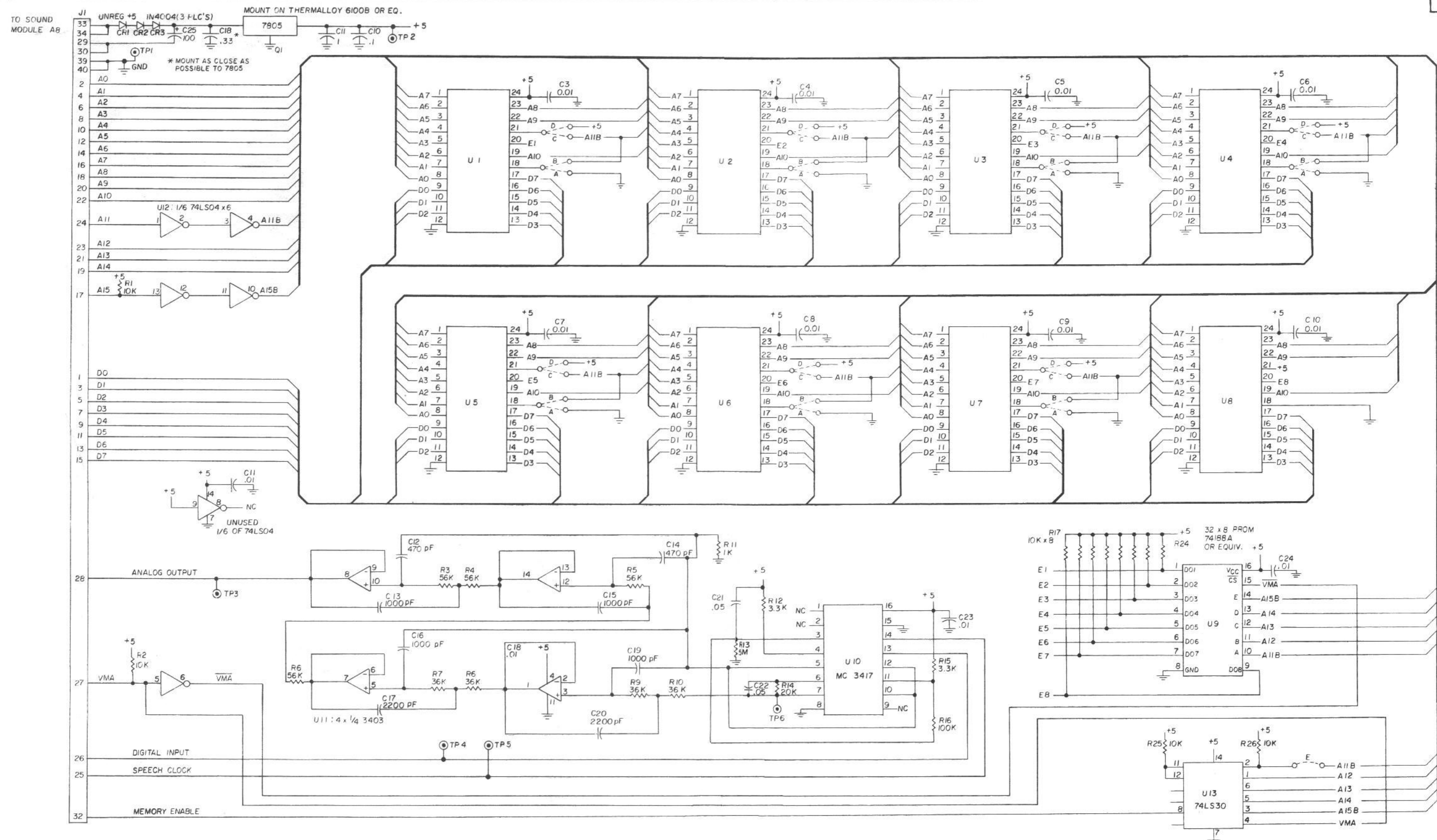

- NOTES:
1. ALL RESISTORS ARE 1/4 W, ±5%.
 2. ALL CAPACITORS ARE IN MFD'S, UNLESS INDICATED OTHERWISE.
 3. U1 THROUGH U7 CAN BE ANY COMBINATION OF 2Kx8 OR 4Kx8 ROM'S OR EPROMS, THE PARTICULAR CONFIGURATION BEING ACCOMMODATED BY J9 PROGRAM AND JUMPER OPTIONS AS FOLLOWS: 2Kx8 ROM (GI9316B OR EQUIV.) JUMPERS D & A, 2Kx8 EPROM (INTEL 2716 OR EQUIV.) JUMPERS D&A, 4Kx8 ROM (GI RO-3-9332B OR EQUIV.) JUMPERS D & B, 4Kx8 EPROM (TI TMS 2532 OR EQUIV.) JUMPERS D&B, 4Kx8 EPROM (INTEL 2732 OR EQUIV.) JUMPERS C & A.
 4. PREFIX ALL REFERENCE DESIGNATIONS WITH A10.

ALL DESIGN, OPERATIVE AND PROCESS DATA PERTAINING TO THE ARTICLE SHOWN ON THIS SHEET IS THE PROPERTY OF BALLY MFG. CORP. CHICAGO, ILL. THIS INFORMATION IS DISCLOSED IN CONFIDENCE AND IS NOT TO BE COPIED, REPRODUCED, REVEALED TO OR APPROPRIATED BY OTHERS IN ANY MANNER OR IN WHOLE, WITHOUT THE EXPRESS CONSENT OF THE OWNERS. THE PRINT IS LOANED AND MUST NOT BE USED IN ANY MANNER DETRIMENTAL TO THE INTEREST OF THE OWNERS, AND MUST BE RETURNED ON DEMAND.

Bally MANUFACTURING CORP.
2640 BELMONT AVENUE
CHICAGO, ILLINOIS 60618

DR. BY: FFC DATE: 5/5/80
CK. BY: AMCR DATE: 7/2/80
AP'D BY: DATE: 8/23/80
FINISH: 8/23/80

REMOVE ALL BURRS
TOLERANCES ON DIMENSIONS UNLESS OTHERWISE SPECIFIED
FRACTIONS ± .008
DECIMALS ± .003
EXCEPT HOLE DIA'S
ANGLES ± 1/2°
DO NOT SCALE DRAWING

HARDENING: _____

NAME: VOCALIZER "A10"
MATERIAL: _____
CODE: _____

ASSEM. NO. USED: _____
SCALE: _____

PART NO. W-1236-c

OPER.	DEPT.	DESCRIPTION	TOOL NO.

NO.	LET.	CHANGE	DATE	BY

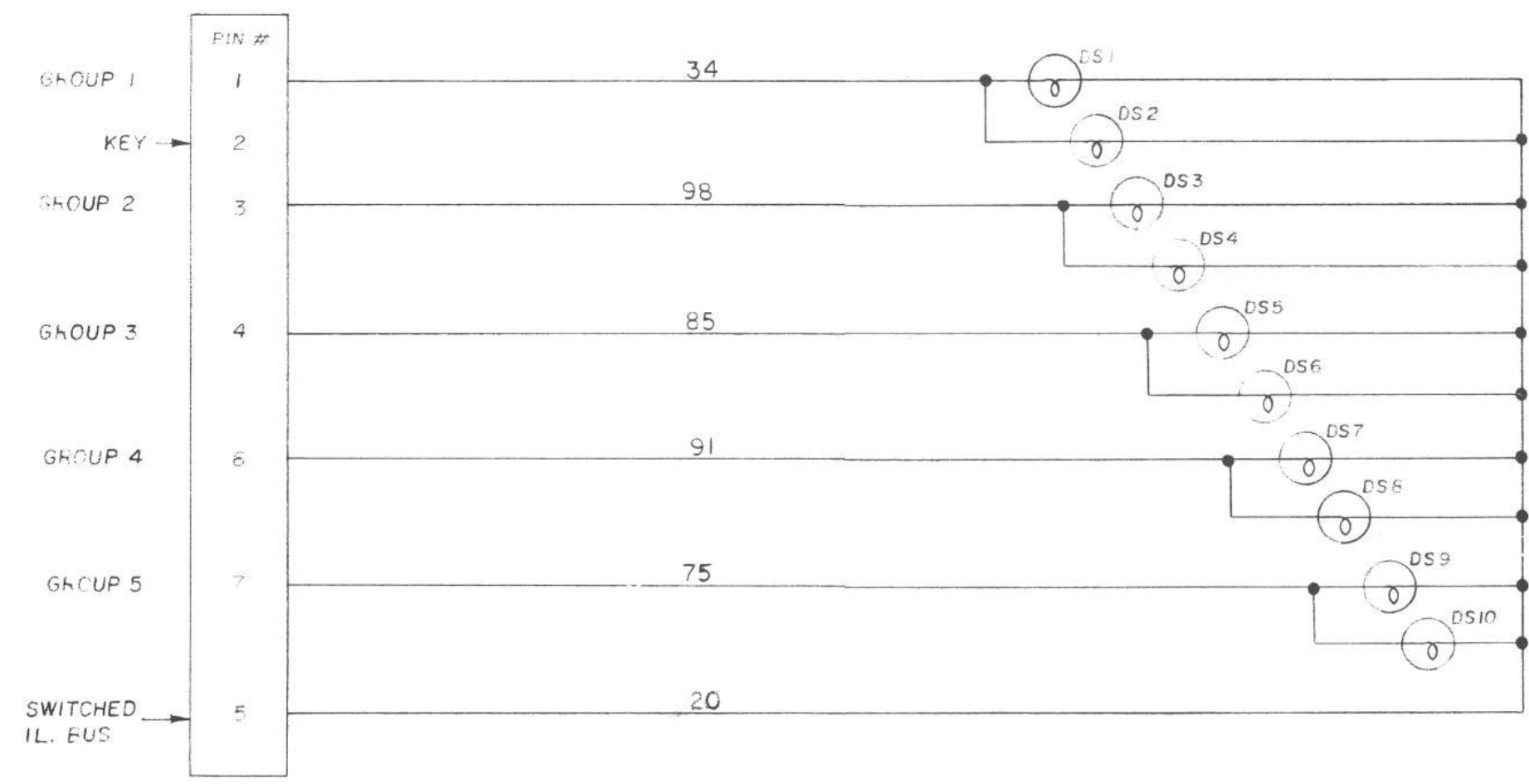

ALL DESIGN, OPERATIVE AND PROCESS DATA PERTAINING TO THE ARTICLE SHOWN ON THIS SHEET IS THE PROPERTY OF BALLY MFG. CORP., CHICAGO, ILL. THIS INFORMATION IS DISCLOSED IN CONFIDENCE AND IS NOT TO BE COPIED, REPRODUCED, REVEALED TO OR APPROPRIATED BY OTHERS, IN PART OR IN WHOLE, WITHOUT THE EXPRESS CONSENT OF THE OWNERS. THE PRINT IS LOANED AND MUST NOT BE USED IN ANY MANNER DETRIMENTAL TO THE INTEREST OF THE OWNERS, AND MUST BE RETURNED ON DEMAND.

REMOVE ALL BURRS		DR. BY FFC	DATE 8-19-80	Bally MANUFACTURING CORP. 2640 BELMONT AVENUE CHICAGO, ILLINOIS #119LE	
TOLERANCES ON DIMENSIONS UNLESS OTHERWISE SPECIFIED FRACTIONS ± .008 DECIMALS ± .003 EXCEPT HOLE DIA'S ANGLES ± 1/2°		CK. BY JSC	DATE 8-22-80		
DO NOT SCALE DRAWING		AP'D BY	DATE	PRINT CONTROL	DIE SIZE
		AP'D BY	DATE	C.C.	FT. PER M.
		FINISH:	NAME ZENON LIGHT STRIP SCHEMATIC		ASSEM. NO. USED
		HARDENING:	MATERIAL		SCALE
				CODE	PART NO. W-1207-4b

OPER.	DEPT.	DESCRIPTION	TOOL NO.

NO.	LET.	CHANGE	DATE	BY

TABLE A AIJ2

FROM	PIN	WIRE
A2J3-11	1	20
A2J4-14	2	12
A2J4-8	3	40
A2J4-4	4	10
A5J2-23	5	97
A5J2-15	6	23
A5J2-22	7	62
A5J2-8	8	70
A5J2-1	9	60
A5J2-2	10	20
A5J2-11	11	95
A5J2-21	12	47
A5J2-10	13	35
A5J2-7	14	91
A5J2-6	15	85
A5J2-20	16	98
A5J2-16	17	34
A2J4-1	18	50
A2J4-9	19	70
A5J2-13	20	53
A5J2-12	21	61
A5J2-4	22	72
A5J2-3	23	84
	24	

AI INSERT

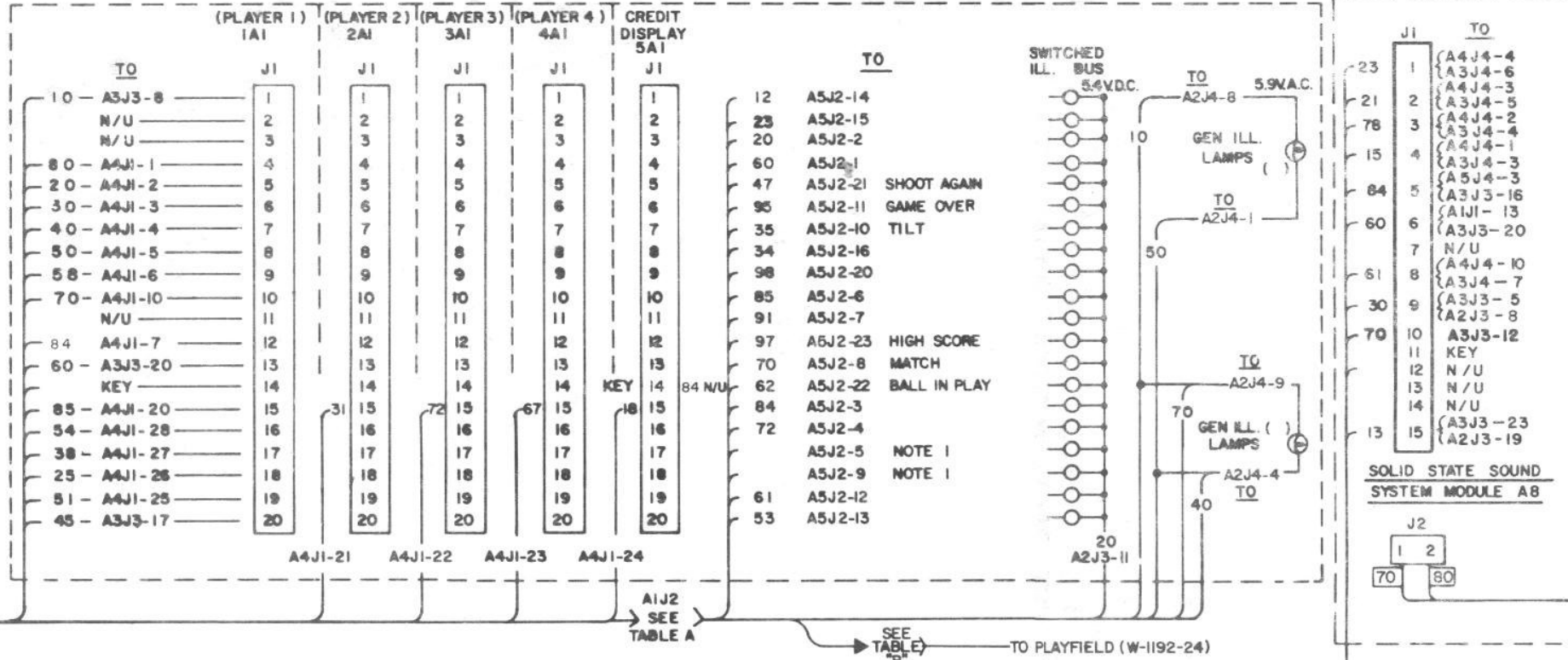

TABLE "B"

FROM	TO	WIRE
A5J2-14	1	12
A5J2-2	2	20
A5J2-15	3	23
A9J2-25	4	25
A5J2-16	5	34
A9J2-17	6	43
A9J2-9	7	54
A5J2-1	8	60
A5J2-6	9	85
A5J2-7	10	91
A5J2-20	11	98

PANEL TO BACK CAB. PLUG

INSERT TO BACK CAB. PLUG

LAMP DRIVER A5

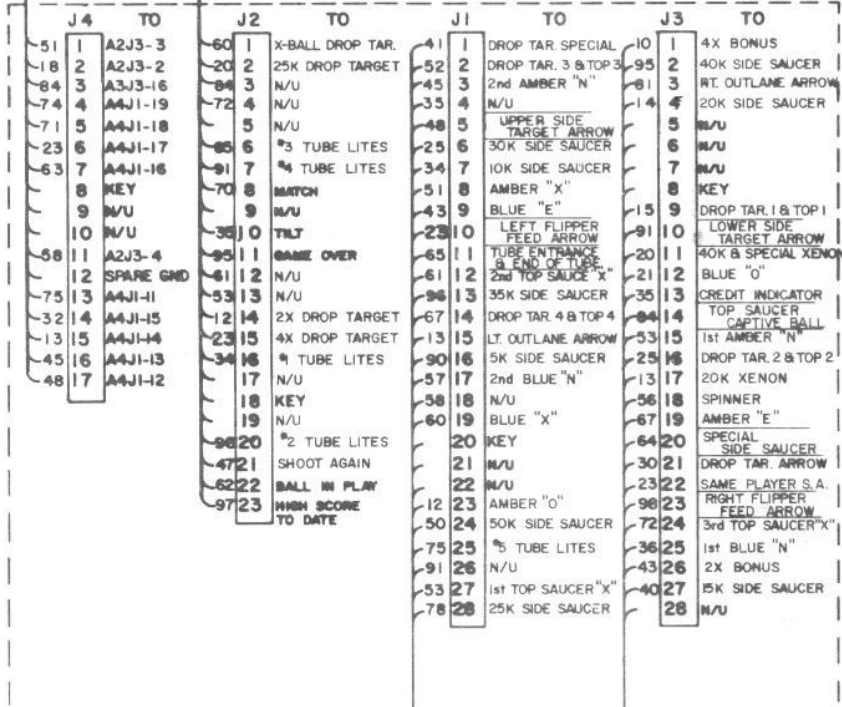

MPU A4

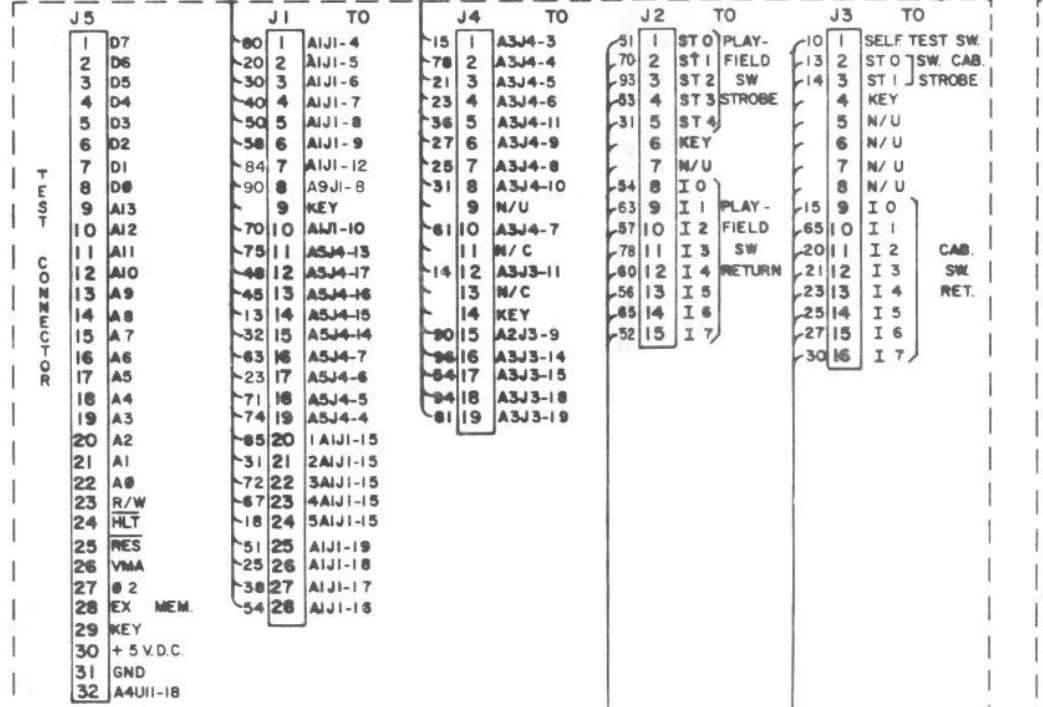

VOLTAGE REGULATOR / SOLENOID DRIVER A3

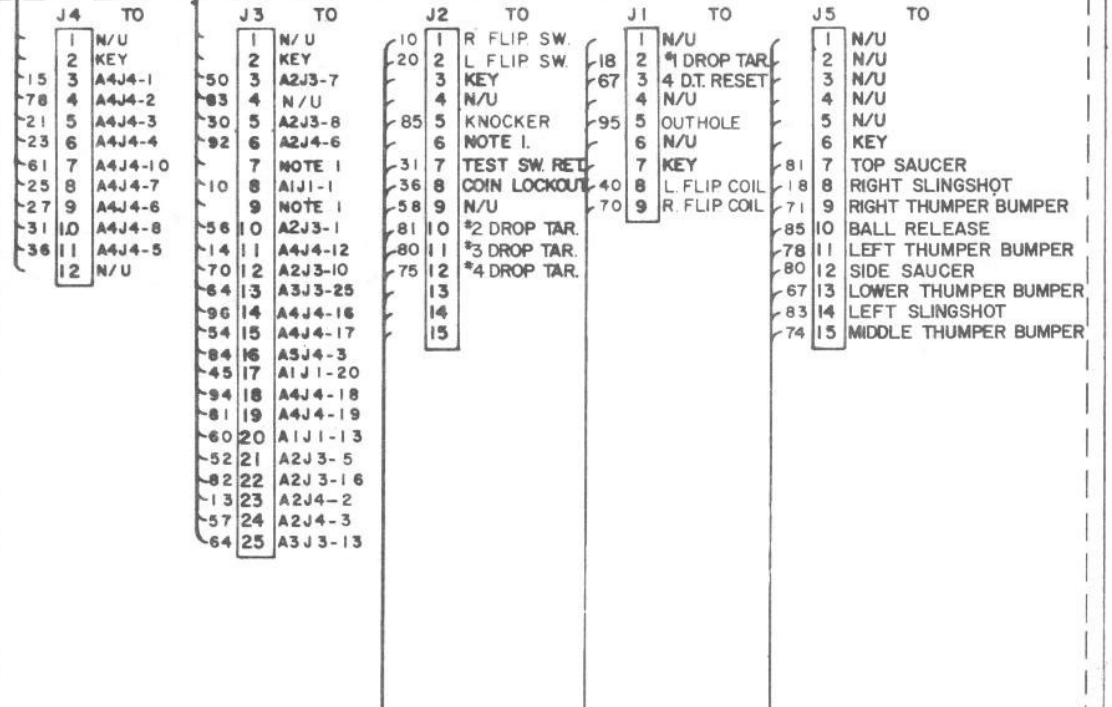

NOTES:

1. THESE PINS ARE RESERVED FOR FUTURE USE.
2. WIRE COLOR ARE SHOWN FOR ALL CONNECTOR PINS, SOME WIRE MAY NOT BE USED IN ALL GAMES.
3. * INDICATES AID TEST POINT.

WIRE COLOR CODE

1-RED	6-BROWN
2-BLUE	7-ORANGE
3-YELLOW	8-BLACK
4-GREEN	9-GRAY
5-WHITE	0-NO TRACE

ALL DESIGN OPERATIVE AND PROCESS DATA PERTAINING TO THE ARTICLE SHOWN ON THIS SHEET IS THE PROPERTY OF BALLY MFG. CO. CHICAGO ILL. THIS INFORMATION IS DISCLOSED IN CONFIDENCE AND IS NOT TO BE COPIED, REPRODUCED, REVEALED, OR APPROPRIATED BY OTHERS IN PART OR IN WHOLE WITHOUT THE EXPRESS CONSENT OF THE OWNERS. THE PRINT IS LOANED AND MUST NOT BE USED IN ANY MANNER DETRIMENTAL TO THE INTEREST OF THE OWNERS AND MUST BE RETURNED ON DEMAND.

DR. BY PER 9-7-80	DATE 9-7-80	Bally MANUFACTURING CORP. 2640 BELMONT AVENUE CHICAGO ILLINOIS		1196
APPROVED BY DATE 9-26-80	PRINT CONTROL	TOLERANCES UNLESS OTHERWISE SPECIFIED FRACTIONS - 1/64 DECIMALS - .005 ANGLES - °		SCALE
FINISH	PLUG CONNECTORS		PART NO W-1187-24c	
HARDENING	MATERIAL XENON		ASSEMBLY NO. USED ON	
LET	CHARGE	DATE	BY	CR.