

REVISIONS			
REV.	DESCRIPTION	DATE	APPR.
A	RELEASE FOR PRODUCTION	06/02/2015	WWW
B	10-000013-01 WAS 10-0013-01	11/02/2016	WWW

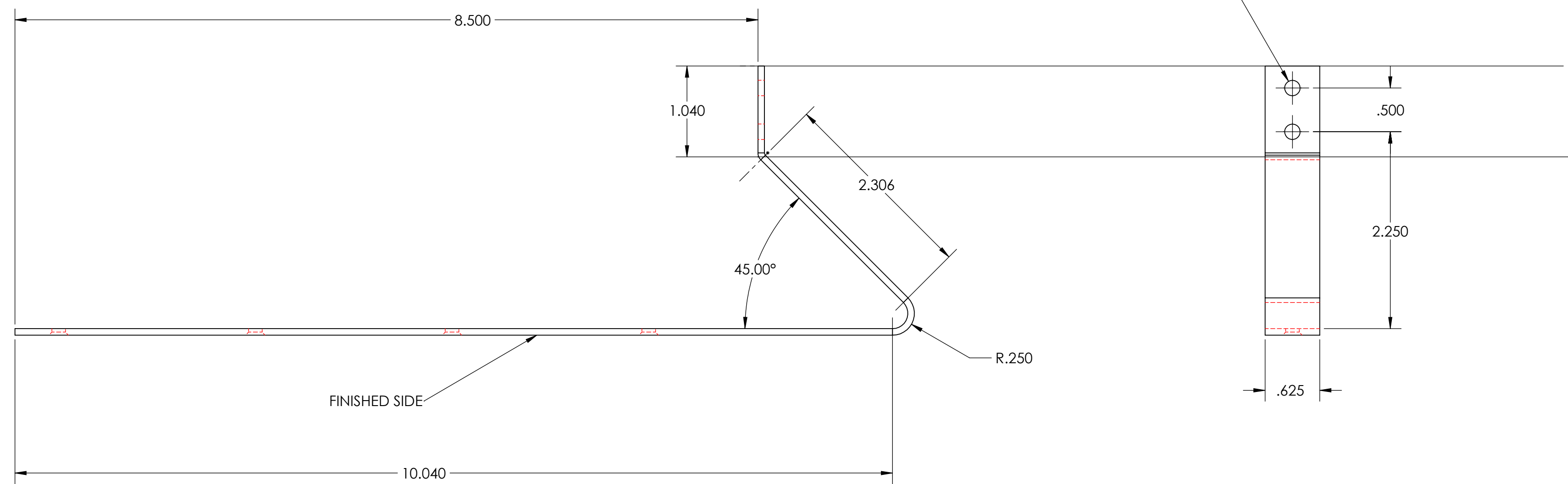
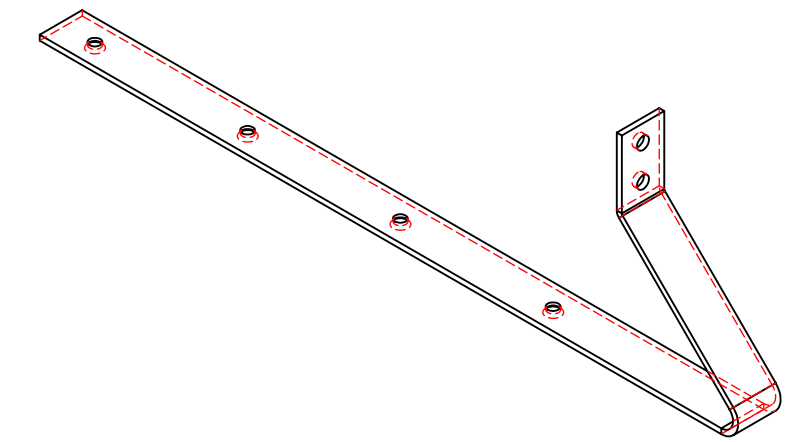
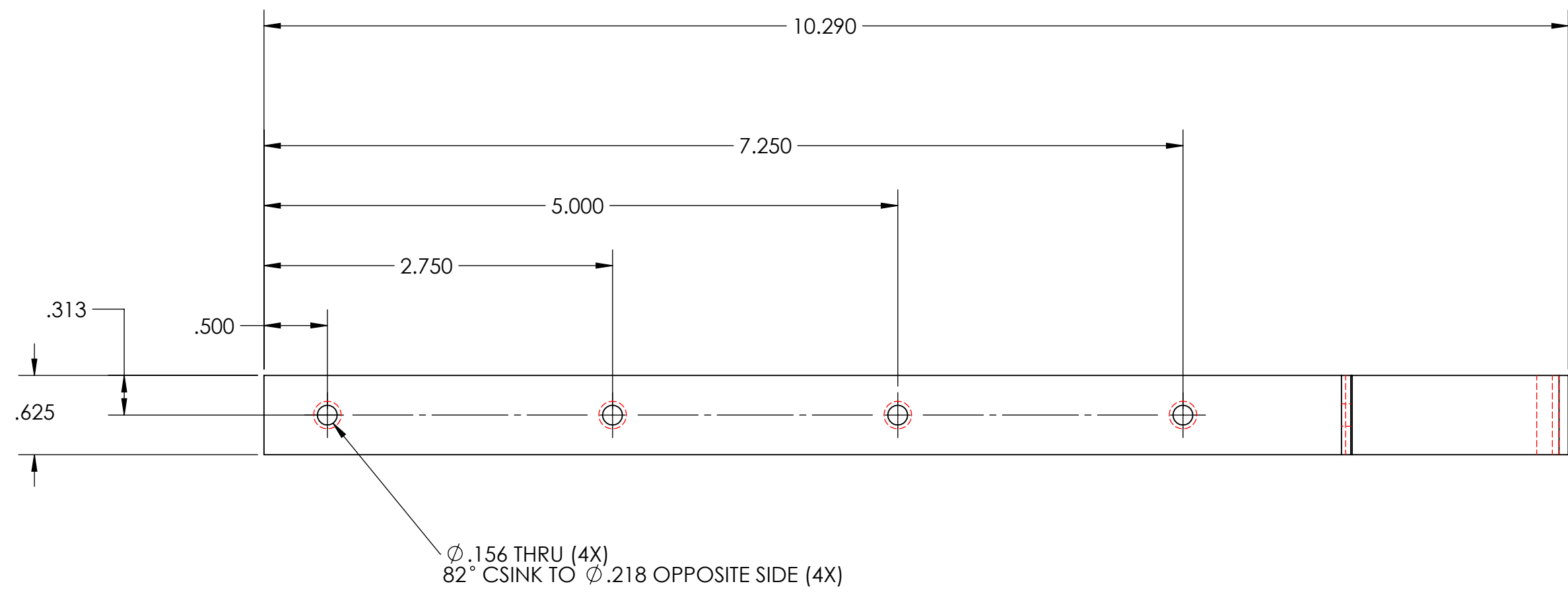

- NOTE:**
- PART TO BE FREE FROM BURRS AND SHARP CORNERS & EDGES.
 - PART TO BE FABRICATED FROM ELECTRONIC FILES SUPPLIED BY JERSEY JACK PINBALL.

SHEET METAL BEND RADIUS AND ALLOWANCE VALUES ARE NOT CORRECT. ALL MATERIAL, HARDWARE, AND FINISH MUST BE RoHS COMPLIANT. THE INFORMATION CONTAINED IN THIS DRAWING IS THE SOLE PROPERTY OF JJ PINBALL, LLC. ANY REPRODUCTION IN PART OR AS A WHOLE WITHOUT THE WRITTEN PERMISSION OF JJ PINBALL, LLC IS PROHIBITED.	MATERIAL	14 GA.(.075) 304 ST STEEL	DRAWN BY	JJ PINBALL, LLC	
	FINISH	NO. 3 FINISH (POLISHED ONE SIDE)	DATE	PLAYFIELD SLIDE SUPPORT	
	FILE LOCATION		SCALE	DWG. NO.	REV
			C 1:1	BRKT 10-000013-01	B