

# SPECIFICATION FOR APPROVAL

- ( ) Preliminary Specification  
( ◆ ) Final Specification

Title	15.6" FHD TFT LCD
-------	-------------------

Customer	Dell
MODEL	

SUPPLIER	LG Display Co., Ltd.
*MODEL	LP156WF1
Suffix	TLB1

\*When you obtain standard approval,  
please use the above model name without suffix

APPROVED BY	SIGNATURE
/	_____
/	_____
/	_____

Please return 1 copy for your confirmation with your signature and comments.

APPROVED BY	SIGNATURE
G. J. Kwon / S.Manager	_____
<b>REVIEWED BY</b>	
S. R. Kim / Manager	_____
<b>PREPARED BY</b>	
C. J. Park / Engineer	_____

Products Engineering Dept.  
LG Display Co., Ltd

## Product Specification

## Contents

No	ITEM	Page
	COVER	1
	CONTENTS	2
	RECORD OF REVISIONS	3
1	GENERAL DESCRIPTION	4
2	ABSOLUTE MAXIMUM RATINGS	5
3	ELECTRICAL SPECIFICATIONS	
3-1	ELECTRICAL CHARACTERISTICS	6
3-2	INTERFACE CONNECTIONS	7
3-3	LVDS SIGNAL TIMING SPECIFICATION	8-9
3-3	SIGNAL TIMING SPECIFICATIONS	10
3-4	SIGNAL TIMING WAVEFORMS	10
3-5	COLOR INPUT DATA REFERENCE	11
3-6	POWER SEQUENCE	12
4	OPTICAL SPECIFICATIONS	13-15
5	MECHANICAL CHARACTERISTICS	16-19
A	APPENDIX. LPL PROPOSAL FOR SYSTEM COVER DESIGN	20-22
6	RELIABILITY	23
7	INTERNATIONAL STANDARDS	
7-1	SAFETY	24
7-2	EMC	24
8	PACKING	
8-1	DESIGNATION OF LOT MARK	25
8-2	PACKING FORM	25
9	PRECAUTIONS	26-27
A	APPENDIX. Enhanced Extended Display Identification Data	28-30



Product Specification

### 1. General Description

The LP156WF1 is a Color Active Matrix Liquid Crystal Display with an integral Light Emitting Diode (LED) backlight system. The matrix employs a-Si Thin Film Transistor as the active element. It is a transmissive type display operating in the normally white mode. This TFT-LCD has 15.6 inches diagonally measured active display area with HD resolution(1080 vertical by 1920 horizontal pixel array). Each pixel is divided into Red, Green and Blue sub-pixels or dots which are arranged in vertical stripes. Gray scale or the brightness of the sub-pixel color is determined with a 6-bit gray scale signal for each dot, thus, presenting a palette of more than 262,144 colors.

The LP156WF1 has been designed to apply the interface method that enables low power, high speed, low EMI.

The LP156WF1 is intended to support applications where thin thickness, low power are critical factors and graphic displays are important. In combination with the vertical arrangement of the sub-pixels, the LP156WF1 characteristics provide an excellent flat display for office automation products such as Notebook PC.

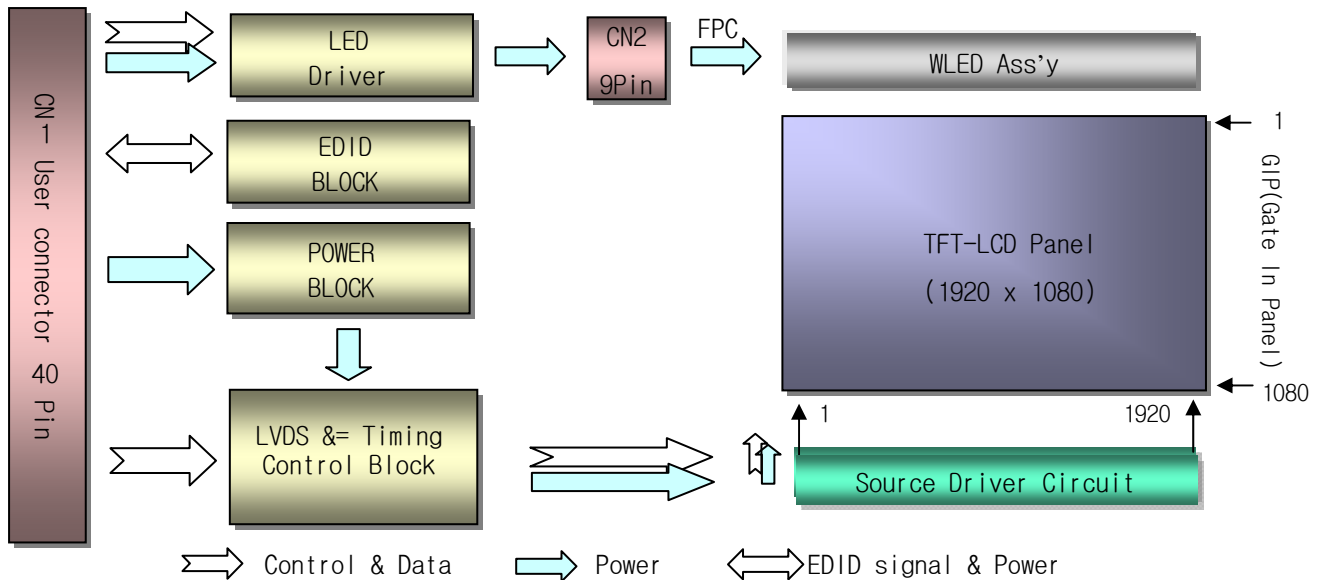

### General Features

Active Screen Size	15.6 inches diagonal
Outline Dimension	359.3(H, typ.) × 209.5(V, typ.) × 5.7(D,max) [mm]
Pixel Pitch	0.17925 mm x 0.17925 mm
Pixel Format	1920 horiz. By 1080 vert. Pixels RGB strip arrangement
Color Depth	6-bit, 262,144 colors
Luminance, White	300 cd/m <sup>2</sup> (Typ.5 point)
Power Consumption	Total 6.35 Watt(Typ.) @ LCM circuit 1.74 Watt(Typ.), B/L (W/O LED Driver) 4.61 Watt(Typ.)
Weight	470g (Max.)
Display Operating Mode	Transmissive mode, normally white
Surface Treatment	<b>Anti-Glare treatment of the front polarizer(3H)</b>
RoHS Comply	Yes

Product Specification

**2. Absolute Maximum Ratings**

The following are maximum values which, if exceeded, may cause faulty operation or damage to the unit.

**Table 1. ABSOLUTE MAXIMUM RATINGS**

Parameter	Symbol	Values		Units	Notes
		Min	Max		
Power Input Voltage	VCC	-0.3	4.0	Vdc	at 25 ± 5°C
Operating Temperature	TOP	0	50	°C	1
Storage Temperature	HST	-20	60	°C	1
Operating Ambient Humidity	HOP	10	90	%RH	1
Storage Humidity	HST	10	90	%RH	1

Note : 1. Temperature and relative humidity range are shown in the figure below.  
Wet bulb temperature should be 39°C Max, and no condensation of water.

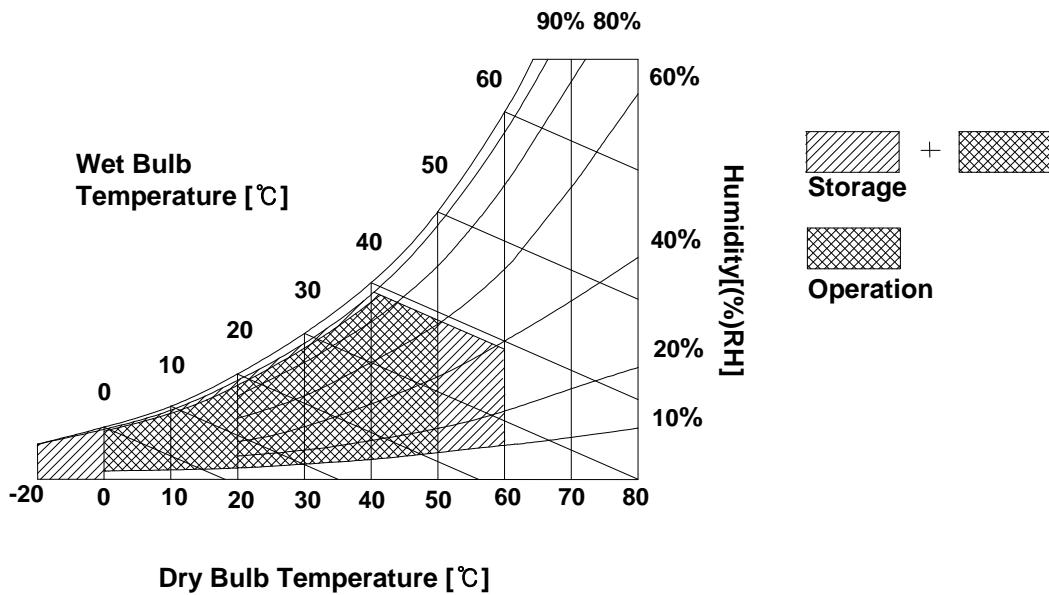

### 3. Electrical Specifications

#### 3-1. Electrical Characteristics

The LP156WF1 requires two power inputs. The first logic is employed to power the LCD electronics and to drive the TFT array and liquid crystal. The second backlight is the input about LED BL.with LED Driver.

**Table 2. ELECTRICAL CHARACTERISTICS**

Parameter	Symbol	Values			Unit	Notes
		Min	Typ	Max		
LOGIC :						
Power Supply Input Voltage	VCC	3.0	3.3	3.6	V <sub>DC</sub>	1
Power Supply Input Current	I <sub>CC</sub>	-	530	610	mA	1
Power Consumption	P <sub>c</sub>	-	1.74	2.0	Watt	
Power Supply Inrush Current	I <sub>CC_P</sub>	-	-	1500	mA	
Differential Impedance	Z <sub>m</sub>	90	100	110	Ohm	2
BACKLIGHT : ( W/O LED Driver)						
LED Power Input Voltage	V <sub>LED</sub>	7.0	-	20	V	
LED Power Input Current	I <sub>LED</sub>	-	-	-	mA	3
LED Power Consumption	P <sub>LED</sub>	-	4.61	4.88	W	3
LED Power Inrush Current	I <sub>LED_P</sub>	-	-	2000	mA	
PWM Dimming (Duty) Ratio	-	12.5	-	100	%	4
PWM Impedance	Z <sub>PWM</sub>	20	40	60	kΩ	
PWM Frequency	F <sub>PWM</sub>	200	-	1000	Hz	5
PWM High Level Voltage	V <sub>PWM_H</sub>	3.0	3.3	5.3	V	
PWM Low Level Voltage	V <sub>PWM_L</sub>	0	-	0.5	V	
LED_EN High Voltage	V <sub>LED_EN_H</sub>	3.0	3.3	5.3	V	
LED_EN Low Voltage	V <sub>LED_EN_L</sub>	0	-	0.5	V	
Life Time		15,000	-	-	Hrs	6

Note)

- The specified I<sub>cc</sub> current and power consumption are under the V<sub>cc</sub> = 3.3V , 25°C , f<sub>v</sub> = 60Hz condition whereas Mosaic pattern is displayed and f<sub>v</sub> is the frame frequency.

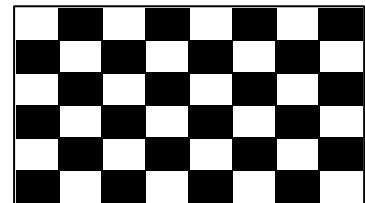

- This impedance value is needed to proper display and measured form LVDS Tx to the mating connector.
- The specified LED current and power consumption are under the V<sub>led</sub> = 12.0V , 25°C , Dimming of Max luminance whereas White pattern is displayed and f<sub>v</sub> is the frame frequency.
- The operation of LED Driver below minimum dimming ratio may cause flickering or reliability issue.
- This Spec. is not effective at 100% dimming ratio as an exception because it has DC level equivalent to 0Hz. In spite of acceptable range as defined, the PWM Frequency should be fixed and stable for more consistent brightness control at any specific level desired.
- The life time is determined as the sum of the continuous operation time at which brightness of LCD at the typical LED current is 50% compare to that of minimum value specified in table 9 under general user condition.

### 3-2. Interface Connections

This LCD employs one interface connections, a 40 pin connector is used for the module electronics interface and LED Driver.

The electronics interface connector is a model 20455-040E-0x manufactured by I-PEX.

**Table 3. MODULE CONNECTOR PIN CONFIGURATION (CN1)**

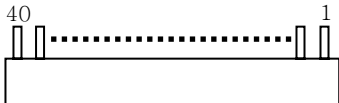
Pin	Symbol	Description	Notes
1	NC	Reserved ( connector test )	<p>1, Interface chips 1.1 LCD : SW, ST2_BS (LCD Controller) including LVDS Receiver 1.2 System : THC63LVDF823A or equivalent * Pin to Pin compatible with LVDS</p> <p>2. Connector 2.1 LCD : 20455-040E-0x, I-PEX or its compatibles 2.2 Mating : 20453-040T-0x, I-PEX or equivalent. 2.3 Connector pin arrangement</p>  <p>[LCD Module Rear View]</p>
2	VCC	Power Supply, 3.3V Typ.	
3	VCC	Power Supply, 3.3V Typ.	
4	V EEDID	DDC 3.3V power	
5	BIST	Built-In Self Test	
6	Clk EEDID	DDC Clock	
7	DATA EEDID	DDC Data	
8	Odd_Rin0-	Negative LVDS differential data input	
9	Odd_Rin0+	Positive LVDS differential data input	
10	VSS1	Ground	
11	Odd_Rin1-	Negative LVDS differential data input	
12	Odd_Rin1+	Positive LVDS differential data input	
13	VSS2	Ground	
14	Odd_Rin2-	Negative LVDS differential data input	
15	Odd_Rin2+	Positive LVDS differential data input	
16	VSS3	Ground	
17	Odd_ClkIN-	Negative LVDS differential clock input	
18	Odd_ClkIN+	Positive LVDS differential clock input	
19	VSS4	Ground	
20	Even_Rin0-	Negative LVDS differential data input	
21	Even_Rin0+	Positive LVDS differential data input	
22	VSS5	Ground	
23	Even_Rin1-	Negative LVDS differential data input	
24	Even_Rin1+	Positive LVDS differential data input	
25	VSS6	Ground	
26	Even_Rin2-	Negative LVDS differential data input	
27	Even_Rin2+	Positive LVDS differential data input	
28	VSS7	Ground	
29	Even_ClkIN-	Negative LVDS differential clock input	
30	Even_ClkIN+	Positive LVDS differential clock input	
31	VLED_GND	LED Ground	
32	VLED_GND	LED Ground	
33	VLED_GND	LED Ground	
34	NC	Reserved ( connector test )	
35	BLIM	PWM for Luminance control	
36	BL_On	Backlight On/Off Control	
37	NC	No Connection	
38	VLED	LED Power Supply (7V-20V)	
39	VLED	LED Power Supply (7V-20V)	
40	VLED	LED Power Supply (7V-20V)	





**Product Specification**

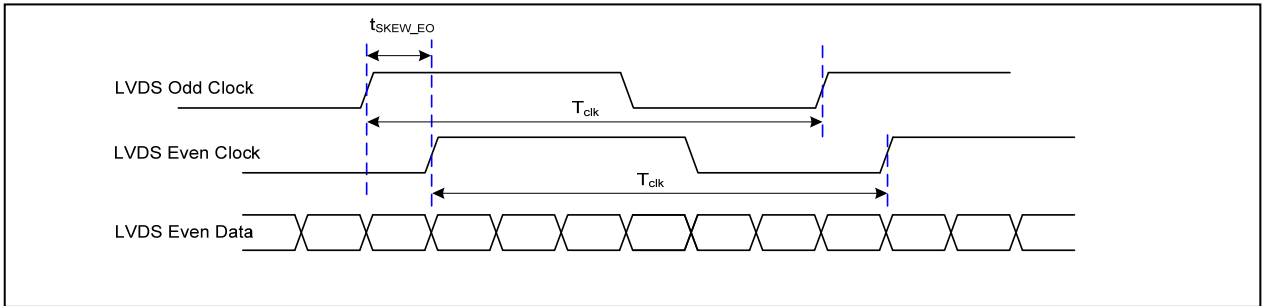

< Clock skew margin between channel >

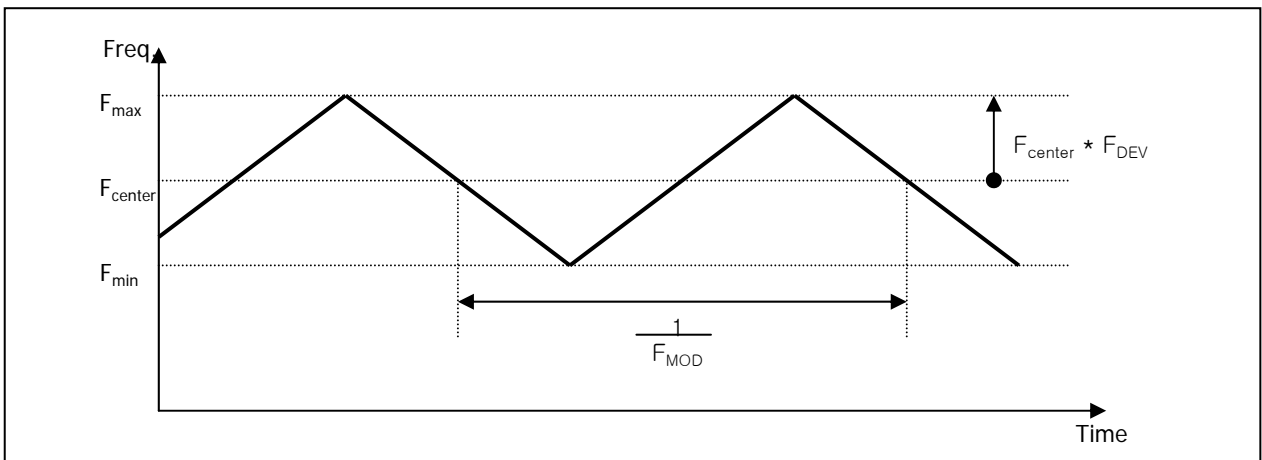

< Spread Spectrum >

**3-3-3. Data Format**

1) LVDS 2 Port

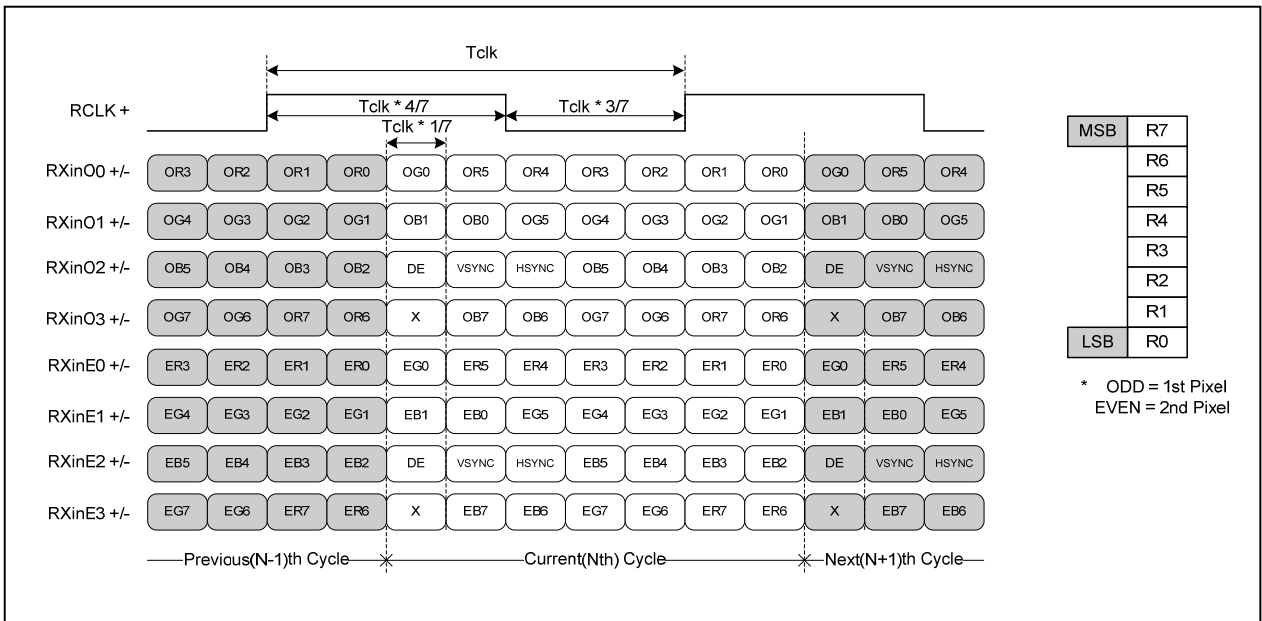

< LVDS Data Format >

### 3-4. Signal Timing Specifications

This is the signal timing required at the input of the User connector. All of the interface signal timing should be satisfied with the following specifications and specifications of LVDS Tx/Rx for its proper operation.

**Table 6. TIMING TABLE**

ITEM	Symbol	Min	Typ	Max	Unit	Note	
DCLK	Frequency	$f_{CLK}$	-	69.25	-	MHz	LVDS 2 port
Hsync	Period	$t_{HP}$	1010	1040	1078	tCLK	
	Width	$t_{WH}$	16	16	16		
	Width-Active	$t_{WHA}$	960	960	960		
Vsync	Period	$t_{VP}$	1096	1111	1122	tHP	
	Width	$t_{WV}$	5	5	5		
	Width-Active	$t_{WVA}$	1080	1080	1080		
Data Enable	Horizontal back porch	$t_{HBP}$	24	40	50	tCLK	
	Horizontal front porch	$t_{HFP}$	10	24	52		
	Vertical back porch	$t_{VBP}$	10	23	28	tHP	
	Vertical front porch	$t_{VFP}$	1	3	9		

### 3-5. Signal Timing Waveforms

Condition : VCC = 3.3V

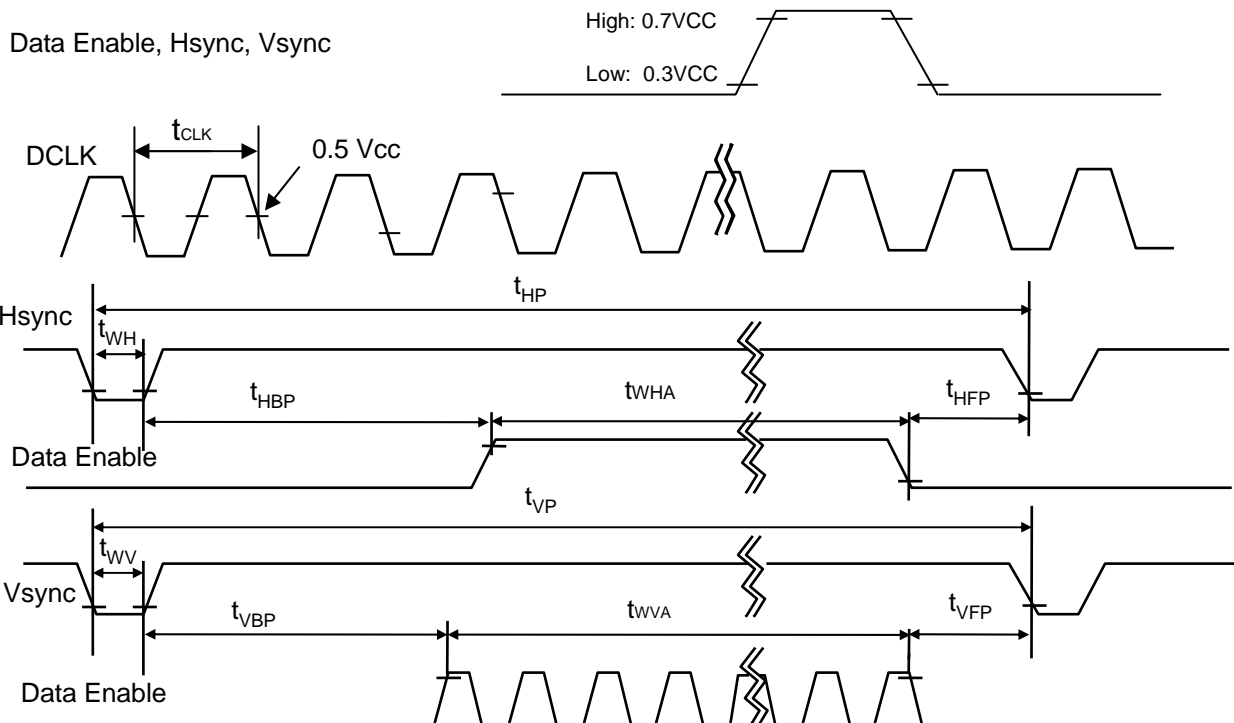

### 3-6. Color Input Data Reference

The brightness of each primary color (red, green and blue) is based on the 6-bit gray scale data input for the color ; the higher the binary input, the brighter the color. The table below provides a reference for color versus data input.

**Table 7. COLOR DATA REFERENCE**

Color		Input Color Data																	
		RED						GREEN						BLUE					
		MSB				LSB		MSB				LSB		MSB		LSB			
		R 5	R 4	R 3	R 2	R 1	R 0	G 5	G 4	G 3	G 2	G 1	G 0	B 5	B 4	B 3	B 2	B 1	B 0
Basic Color	Black	0	0	0	0	0	0	0	0	0	0	0	0	0	0	0	0	0	0
	Red	1	1	1	1	1	1	0	0	0	0	0	0	0	0	0	0	0	0
	Green	0	0	0	0	0	0	1	1	1	1	1	1	0	0	0	0	0	0
	Blue	0	0	0	0	0	0	0	0	0	0	0	0	1	1	1	1	1	1
	Cyan	0	0	0	0	0	0	1	1	1	1	1	1	1	1	1	1	1	1
	Magenta	1	1	1	1	1	1	0	0	0	0	0	0	1	1	1	1	1	1
	Yellow	1	1	1	1	1	1	1	1	1	1	1	1	0	0	0	0	0	0
	White	1	1	1	1	1	1	1	1	1	1	1	1	1	1	1	1	1	1
RED	RED (00)	0	0	0	0	0	0	0	0	0	0	0	0	0	0	0	0	0	0
	RED (01)	0	0	0	0	0	1	0	0	0	0	0	0	0	0	0	0	0	0
	...	...						...						...					
	RED (62)	1	1	1	1	1	0	0	0	0	0	0	0	0	0	0	0	0	0
	RED (63)	1	1	1	1	1	1	0	0	0	0	0	0	0	0	0	0	0	0
GREEN	GREEN (00)	0	0	0	0	0	0	0	0	0	0	0	0	0	0	0	0	0	0
	GREEN (01)	0	0	0	0	0	0	0	0	0	0	0	1	0	0	0	0	0	0
	...	...						...						...					
	GREEN (62)	0	0	0	0	0	0	1	1	1	1	1	0	0	0	0	0	0	0
	GREEN (63)	0	0	0	0	0	0	1	1	1	1	1	1	0	0	0	0	0	0
BLUE	BLUE (00)	0	0	0	0	0	0	0	0	0	0	0	0	0	0	0	0	0	0
	BLUE (01)	0	0	0	0	0	0	0	0	0	0	0	0	0	0	0	0	0	1
	...	...						...						...					
	BLUE (62)	0	0	0	0	0	0	0	0	0	0	0	0	1	1	1	1	1	0
	BLUE (63)	0	0	0	0	0	0	0	0	0	0	0	0	1	1	1	1	1	1

Product Specification

**3-7. Power Sequence**

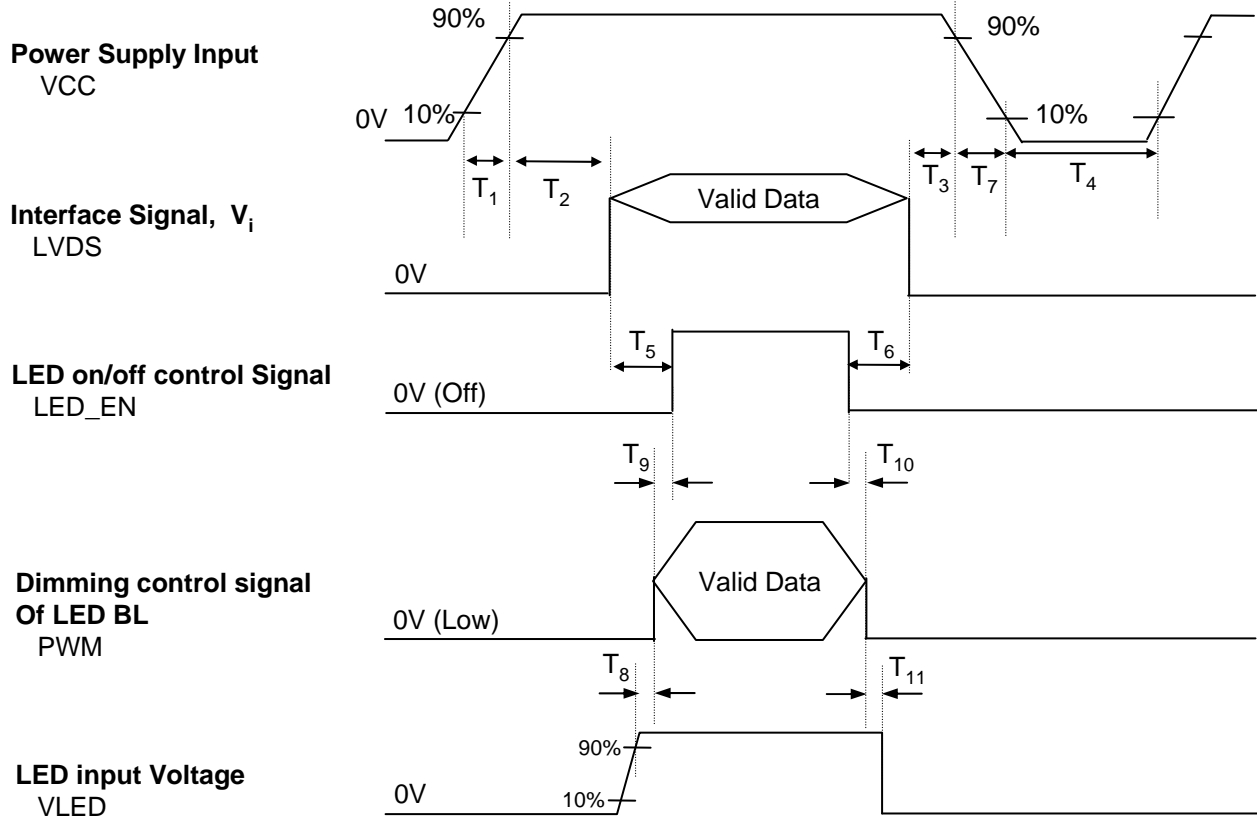

**Table 6. POWER SEQUENCE TABLE**

Parameter	Value			Units
	Min.	Typ.	Max.	
T <sub>1</sub>	0.5	-	10	ms
T <sub>2</sub>	0	-	50	ms
T <sub>3</sub>	0	-	50	ms
T <sub>4</sub>	400	-	-	ms
T <sub>5</sub>	200	-	-	ms
T <sub>6</sub>	200	-	-	ms
T <sub>7</sub>	3	-	10	ms
T <sub>8</sub>	10	-	-	ms
T <sub>9</sub>	0	-	-	ms
T <sub>10</sub>	0	-	-	ms
T <sub>11</sub>	10	-	-	ms

Note)

1. Valid Data is Data to meet "3-3. LVDS Signal Timing Specifications"
2. Please avoid floating state of interface signal at invalid period.
3. When the interface signal is invalid, be sure to pull down the power supply for LCD VCC to 0V.
4. LED power must be turn on after power supply for LCD and interface signal are valid.

#### 4. Optical Specification

Optical characteristics are determined after the unit has been 'ON' and stable for approximately 30 minutes in a dark environment at 25°C. The values specified are at an approximate distance 50cm from the LCD surface at a viewing angle of  $\Phi$  and  $\Theta$  equal to 0°.

FIG. 1 presents additional information concerning the measurement equipment and method.

**FIG. 1 Optical Characteristic Measurement Equipment and Method**

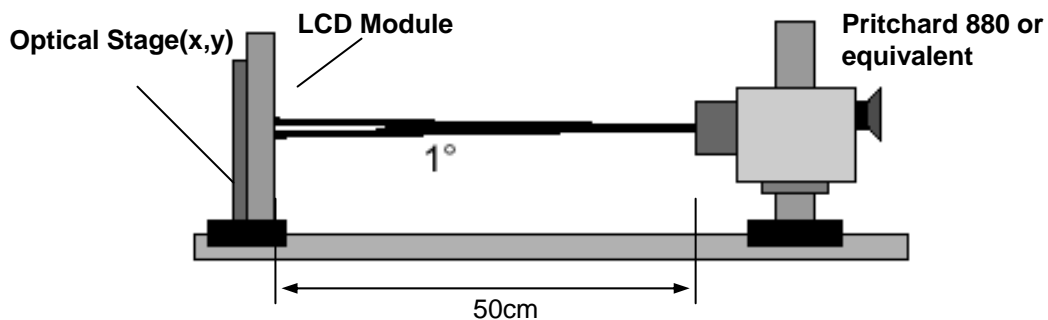

**Table 9. OPTICAL CHARACTERISTICS**

$T_a=25^\circ\text{C}$ ,  $V_{CC}=3.3\text{V}$ ,  $f_v=60\text{Hz}$ ,  $f_{CLK}=69.25\text{MHz}$ ,  $I_{LED}=20\text{mA}$

Parameter	Symbol	Values			Units	Notes
		Min	Typ	Max		
Contrast Ratio	CR	500	-	-		1
Surface Luminance, white	$L_{WH}$	270	300	-	cd/m <sup>2</sup>	2
Luminance Variation	$\delta_{WHITE}$	-	1.4	1.6		3
Response Time	$T_{R+T_D}$	-	8	-	ms	4
Color Coordinates						
RED	RX	0.587	0.617	0.647		
	RY	0.319	0.349	0.379		
GREEN	GX	0.283	0.313	0.343		
	GY	0.565	0.595	0.625		
BLUE	BX	0.121	0.151	0.181		
	BY	0.026	0.056	0.086		
WHITE	WX	0.283	0.313	0.343		
	WY	0.299	0.329	0.359		
Viewing Angle						
x axis, right ( $\Phi=0^\circ$ )	$\Theta_r$	60	-	-	degree	5
x axis, left ( $\Phi=180^\circ$ )	$\Theta_l$	60	-	-	degree	
y axis, up ( $\Phi=90^\circ$ )	$\Theta_u$	50	-	-	degree	
y axis, down ( $\Phi=270^\circ$ )	$\Theta_d$	50	-	-	degree	
Gray Scale						6

Product Specification

Note)

1. Contrast Ratio(CR) is defined mathematically as

$$\text{Contrast Ratio} = \frac{\text{Surface Luminance with all white pixels}}{\text{Surface Luminance with all black pixels}}$$

2. Surface luminance is the average of 5 point across the LCD surface 50cm from the surface with all pixels displaying white. For more information see FIG 1.

$$L_{WH} = \text{Average}(L_1, L_2, \dots L_5)$$

3. The variation in surface luminance , The panel total variation ( $\delta_{WHITE}$ ) is determined by measuring  $L_N$  at each test position 1 through 13 and then defined as followed numerical formula.  
For more information see FIG 2.

$$\delta_{WHITE} = \frac{\text{Maximum}(L_1, L_2, \dots L_{13})}{\text{Minimum}(L_1, L_2, \dots L_{13})}$$

4. Response time is the time required for the display to transition from white to black (rise time,  $Tr_R$ ) and from black to white(Decay Time,  $Tr_D$ ). For additional information see FIG 3.

5. Viewing angle is the angle at which the contrast ratio is greater than 10. The angles are determined for the horizontal or x axis and the vertical or y axis with respect to the z axis which is normal to the LCD surface. For more information see FIG 4.

6. Gray scale specification

\*  $f_V = 60\text{Hz}$

Gray Level	Luminance [%] (Typ)
L0	0
L7	1.00
L15	4.25
L23	10.90
L31	21.01
L39	34.82
L47	52.49
L55	86.56
L63	100

Product Specification

**FIG. 2 Luminance**

<Measuring point for Average Luminance & measuring point for Luminance variation>

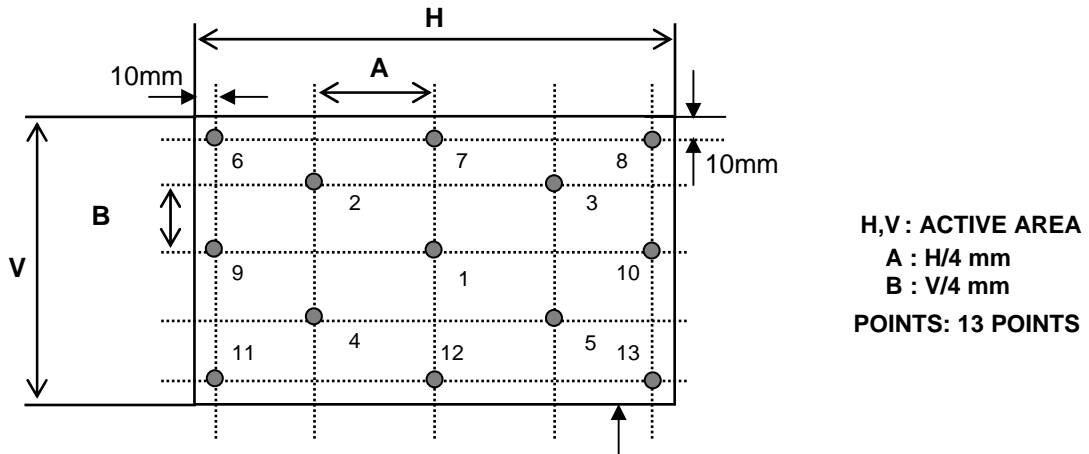

**FIG. 3 Response Time**

Active Area

The response time is defined as the following figure and shall be measured by switching the input signal for "black" and "white".

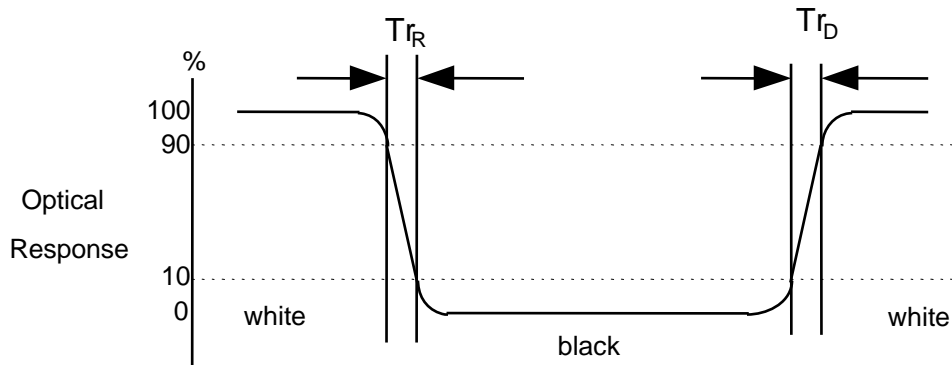

**FIG. 4 Viewing angle**

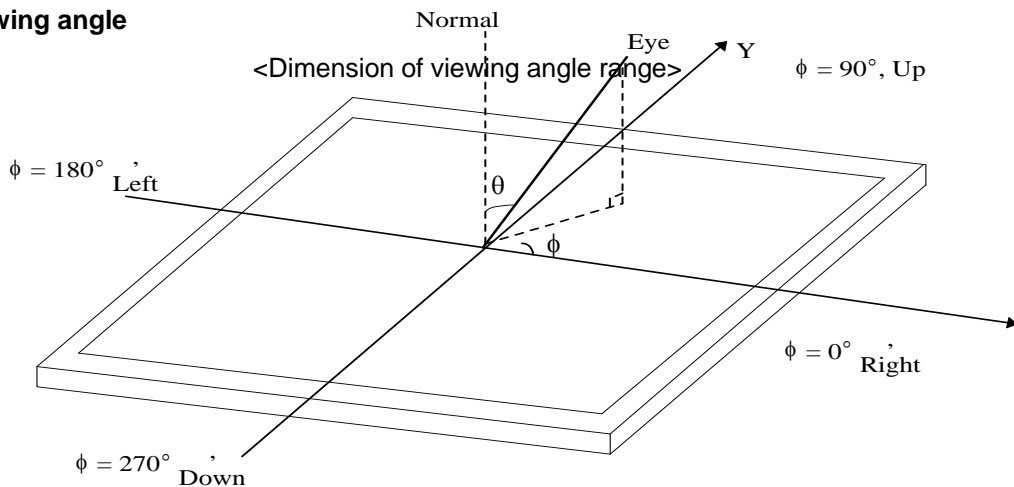

## 5. Mechanical Characteristics

The contents provide general mechanical characteristics for the model LP156WF1. In addition the figures in the next page are detailed mechanical drawing of the LCD.

Outline Dimension	Horizontal	$359.3 \pm 0.5\text{mm}$
	Vertical	$209.5 \pm 0.5\text{mm}$
	Thickness	5.7mm (max)
Bezel Area	Horizontal	$349.8 \pm 0.5\text{mm}$
	Vertical	$197.1 \pm 0.5\text{mm}$
Active Display Area	Horizontal	$344.16 \pm 0.3 \text{ mm}$
	Vertical	$193.59 \pm 0.3 \text{ mm}$
Weight	470g (Max.)	
Surface Treatment	Anti-Glare treatment of the front polarizer(3H)	



**Product Specification**

<FRONT VIEW>

Note) Unit:[mm], General tolerance:  $\pm 0.5$ mm

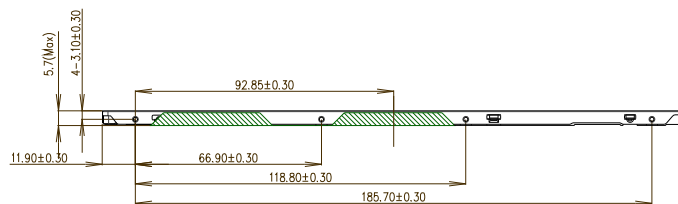
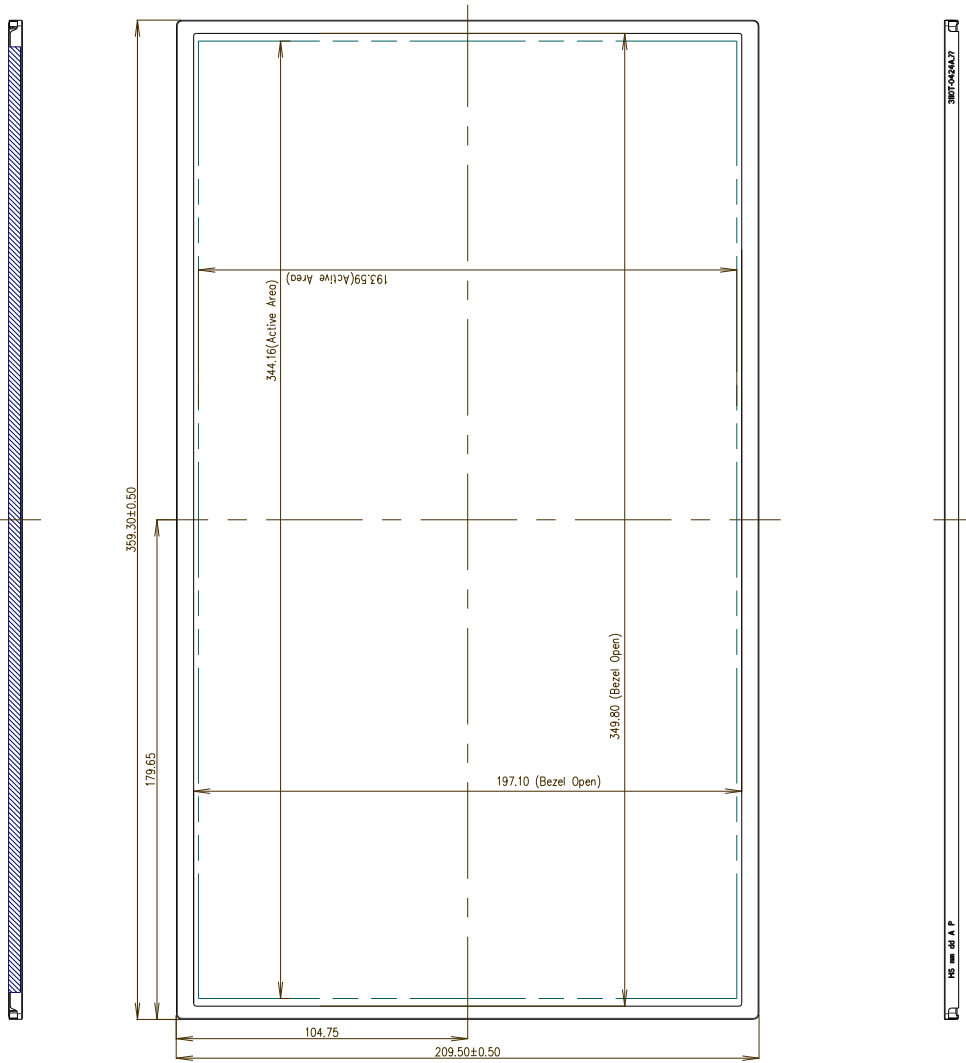
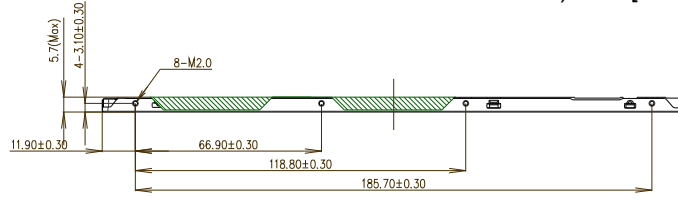

Product Specification

<REAR VIEW>

Note) Unit:[mm], General tolerance:  $\pm 0.5$ mm

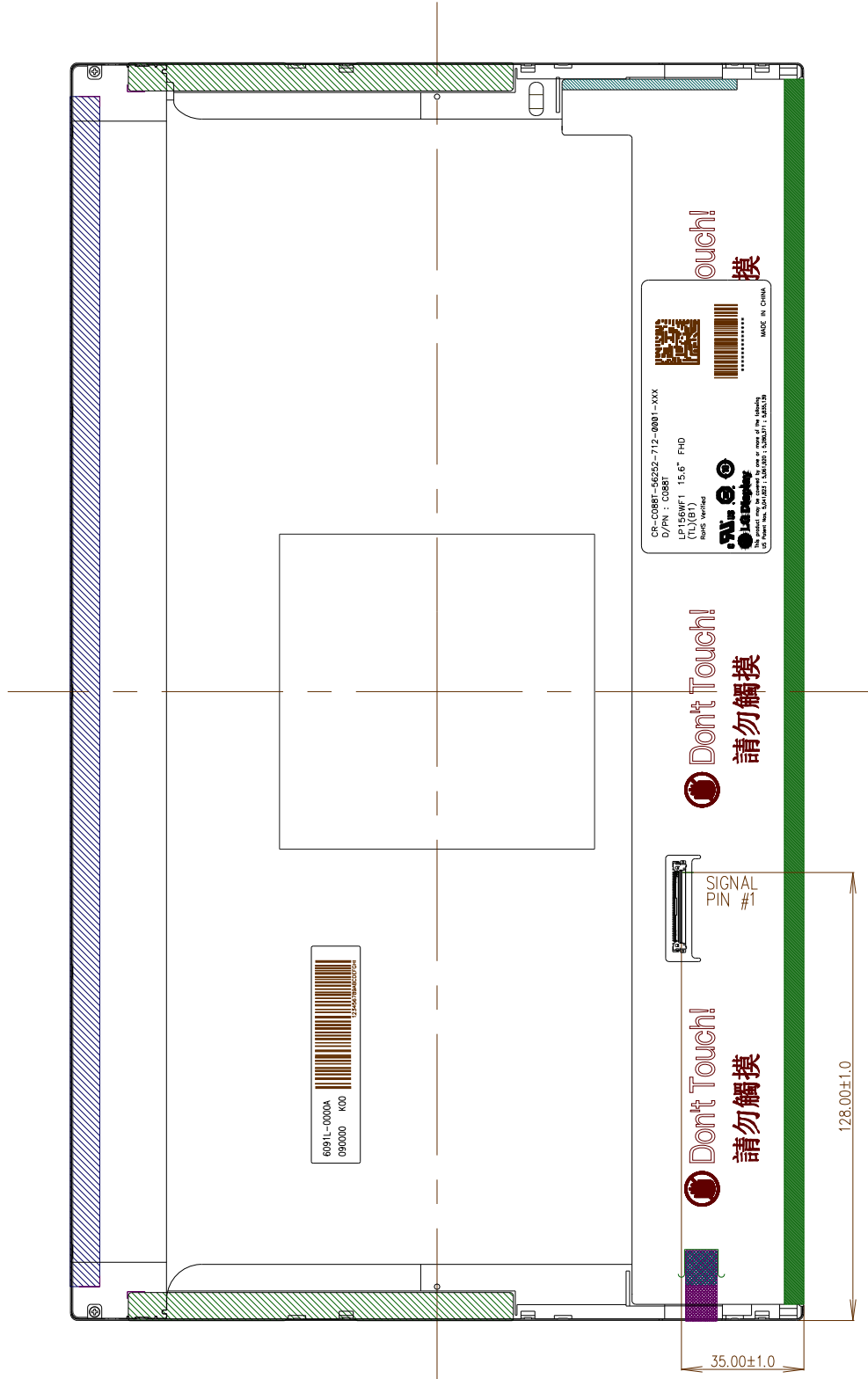

Product Specification

[ DETAIL DESCRIPTION OF SIDE MOUNTING SCREW ]

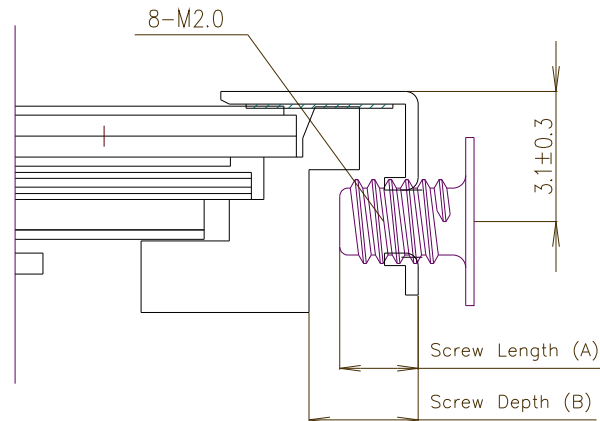

- \* Mounting Screw Length (A)  
= 2.0(Min) / 2.5(Max)
- \* Mounting Screw Hole Depth (B)  
= 2.5(Min)
- \* Mounting hole location : 3.10(typ.)
- \* Torque : 2.0 kgf.cm(Max)  
(Measurement gauge : torque meter)

Notes : 1. Screw plated through the method of non-electrolytic nickel plating is preferred to reduce possibility that results in vertical and/or horizontal line defect due to the conductive particles from screw surface.



LPL Proposal for system cover design.

3	Gap check for securing the enough gap between LCM and System hinge.	
<p>LCM Reflector Side</p> <p>S-PCB</p> <p>Side Mount Screw Hole (4ea)</p> <p>Hinge</p> <p>GAP:Min2.0mm</p> <p>COF (D-IC)</p> <p>("I" TYPE)</p> <p>("L" TYPE)</p>		
Define	<p>1. At least 2.0mm of gap needs to be secured to prevent the shock related defects.</p> <p>2. "L" type of hinge is recommended than "I" type under shock test.</p>	
4	Checking the path of the System wire.	
<p>#6 #5 #4 #3 #2 #1</p> <p>Good Ok Bad</p>		
Define	<p>1. COF area needs to be handled with care.</p> <p>2. GOOD → Wire path design to system side.          OK → Wire path is located between COFs.          BAD → Wire path overlapped with COF area.</p>	



## 6. Reliability

Environment test condition

No.	Test Item	Conditions
1	High temperature storage test	Ta= 60°C, 240h
2	Low temperature storage test	Ta= -20°C, 240h
3	High temperature operation test	Ta= 50°C, 50%RH, 240h
4	Low temperature operation test	Ta= 0°C, 240h
5	Vibration test (non-operating)	Sine wave, 10 ~ 500 ~ 10Hz, 1.5G, 0.37oct/min 3 axis, 1hour/axis
6	Shock test (non-operating)	Half sine wave, 180G, 2ms one shock of each six faces(I.e. run 180G 2ms for all six faces)
7	Altitude operating storage / shipment	0 ~ 10,000 feet (3,048m) 24Hr 0 ~ 40,000 feet (12,192m) 24Hr

{ Result Evaluation Criteria }

There should be no change which might affect the practical display function when the display quality test is conducted under normal operating condition.

## 7. International Standards

### 7-1. Safety

- a) UL 60950-1:2003, First Edition, Underwriters Laboratories, Inc., Standard for Safety of Information Technology Equipment.
- b) CAN/CSA C22.2, No. 60950-1-03 1<sup>st</sup> Ed. April 1, 2003, Canadian Standards Association, Standard for Safety of Information Technology Equipment.
- c) EN 60950-1:2001, First Edition, European Committee for Electrotechnical Standardization(CENELEC) European Standard for Safety of Information Technology Equipment.

### 7-2. EMC

- a) ANSI C63.4 "Methods of Measurement of Radio-Noise Emissions from Low-Voltage Electrical and Electrical Equipment in the Range of 9kHz to 40GHz." American National Standards Institute(ANSI), 1992
- b) C.I.S.P.R "Limits and Methods of Measurement of Radio Interface Characteristics of Information Technology Equipment." International Special Committee on Radio Interference.
- c) EN 55022 "Limits and Methods of Measurement of Radio Interface Characteristics of Information Technology Equipment." European Committee for Electrotechnical Standardization.(CENELEC), 1998 ( Including A1: 2000 )



## 8. Packing

### 8-1. Designation of Lot Mark

#### a) Lot Mark

A	B	C	D	E	F	G	H	I	J	K	L	M
---	---	---	---	---	---	---	---	---	---	---	---	---

A,B,C : SIZE(INCH)  
 E : MONTH

D : YEAR  
 F ~ M : SERIAL NO.

#### Note

##### 1. YEAR

Year	2001	2002	2003	2004	2005	2006	2007	2008	2009	2010
Mark	1	2	3	4	5	6	7	8	9	0

##### 2. MONTH

Month	Jan	Feb	Mar	Apr	May	Jun	Jul	Aug	Sep	Oct	Nov	Dec
Mark	1	2	3	4	5	6	7	8	9	A	B	C

#### b) Location of Lot Mark

Serial No. is printed on the label. The label is attached to the backside of the LCD module.  
 This is subject to change without prior notice.

### 8-2. Packing Form

a) Package quantity in one box : 20 pcs

b) Box Size : 482 x 390 x 275

## 9. PRECAUTIONS

Please pay attention to the followings when you use this TFT LCD module.

### 9-1. MOUNTING PRECAUTIONS

- (1) You must mount a module using holes arranged in four corners or four sides.
- (2) You should consider the mounting structure so that uneven force (ex. Twisted stress) is not applied to the module. And the case on which a module is mounted should have sufficient strength so that external force is not transmitted directly to the module.
- (3) Please attach the surface transparent protective plate to the surface in order to protect the polarizer. Transparent protective plate should have sufficient strength in order to resist external force.
- (4) You should adopt radiation structure to satisfy the temperature specification.
- (5) Acetic acid type and chlorine type materials for the cover case are not desirable because the former generates corrosive gas of attacking the polarizer at high temperature and the latter causes circuit break by electro-chemical reaction.
- (6) Do not touch, push or rub the exposed polarizers with glass, tweezers or anything harder than HB pencil lead. And please do not rub with dust clothes with chemical treatment. Do not touch the surface of polarizer for bare hand or greasy cloth. (Some cosmetics are detrimental to the polarizer.)
- (7) When the surface becomes dusty, please wipe gently with absorbent cotton or other soft materials like chamois soaks with petroleum benzene. Normal-hexane is recommended for cleaning the adhesives used to attach front / rear polarizers. Do not use acetone, toluene and alcohol because they cause chemical damage to the polarizer.
- (8) Wipe off saliva or water drops as soon as possible. Their long time contact with polarizer causes deformations and color fading.
- (9) Do not open the case because inside circuits do not have sufficient strength.

### 9-2. OPERATING PRECAUTIONS

- (1) The spike noise causes the mis-operation of circuits. It should be lower than following voltage :  
 $V = \pm 200\text{mV}$  (Over and under shoot voltage)
- (2) Response time depends on the temperature. (In lower temperature, it becomes longer.)
- (3) Brightness depends on the temperature. (In lower temperature, it becomes lower.)  
And in lower temperature, response time (required time that brightness is stable after turned on) becomes longer.
- (4) Be careful for condensation at sudden temperature change. Condensation makes damage to polarizer or electrical contacted parts. And after fading condensation, smear or spot will occur.
- (5) When fixed patterns are displayed for a long time, remnant image is likely to occur.
- (6) Module has high frequency circuits. Sufficient suppression to the electromagnetic interference shall be done by system manufacturers. Grounding and shielding methods may be important to minimize the interference.

### 9-3. ELECTROSTATIC DISCHARGE CONTROL

Since a module is composed of electronic circuits, it is not strong to electrostatic discharge. Make certain that treatment persons are connected to ground through wrist band etc. And don't touch interface pin directly.

### 9-4. PRECAUTIONS FOR STRONG LIGHT EXPOSURE

Strong light exposure causes degradation of polarizer and color filter.

### 9-5. STORAGE

When storing modules as spares for a long time, the following precautions are necessary.

- (1) Store them in a dark place. Do not expose the module to sunlight or fluorescent light. Keep the temperature between 5°C and 35°C at normal humidity.
- (2) The polarizer surface should not come in contact with any other object.  
It is recommended that they be stored in the container in which they were shipped.

### 9-6. HANDLING PRECAUTIONS FOR PROTECTION FILM

- (1) When the protection film is peeled off, static electricity is generated between the film and polarizer.  
This should be peeled off slowly and carefully by people who are electrically grounded and with well ion-blown equipment or in such a condition, etc.
- (2) The protection film is attached to the polarizer with a small amount of glue. If some stress is applied to rub the protection film against the polarizer during the time you peel off the film, the glue is apt to remain on the polarizer.  
Please carefully peel off the protection film without rubbing it against the polarizer.
- (3) When the module with protection film attached is stored for a long time, sometimes there remains a very small amount of glue still on the polarizer after the protection film is peeled off.
- (4) You can remove the glue easily. When the glue remains on the polarizer surface or its vestige is recognized, please wipe them off with absorbent cotton waste or other soft material like chamois soaked with normal-hexane.

## Product Specification

**APPENDIX A. Enhanced Extended Display Identification Data (EEDID™) 1/3**
**EDID Data for Dell\_LP156WF1-TLB1\_ver. 1.0**

2009.05.11

	Byte (Dec)	Byte (Hex)	Field Name and Comments	Value (Hex)	Value (Bin)
<b>Header</b>	0	00	Header	00	00000000
	1	01	Header	FF	11111111
	2	02	Header	FF	11111111
	3	03	Header	FF	11111111
	4	04	Header	FF	11111111
	5	05	Header	FF	11111111
	6	06	Header	FF	11111111
	7	07	Header	00	00000000
<b>Vendor / Product</b>	8	08	EISA manufacture code ( 3 Character ID ) LGD	30	00110000
	9	09	EISA manufacture code (Compressed ASCII)	E4	11100100
	10	0A	Panel Supplier Reserved - Product Code 0215h	15	00010101
	11	0B	( Hex. LSB first )	02	00000010
	12	0C	LCD Module Serial No - Preferred but Optional ("0" If not used)	00	00000000
	13	0D	LCD Module Serial No - Preferred but Optional ("0" If not used)	00	00000000
	14	0E	LCD Module Serial No - Preferred but Optional ("0" If not used)	00	00000000
	15	0F	LCD Module Serial No - Preferred but Optional ("0" If not used)	00	00000000
	16	10	Week of Manufacture 00 weeks	00	00000000
17	11	Year of Manufacture 2009 years	13	00010011	
18	12	EDID structure version # = 1	01	00000001	
19	13	EDID revision # = 3	03	00000011	
<b>Display</b>	20	14	Video input Definition = Digital signal, 6 bit _ Dell only	90	10010000
	21	15	Max H image size (Rounded cm) = 35 cm	23	00100011
	22	16	Max V image size (Rounded cm) = 19 cm	13	00010011
	23	17	Display gamma = (gamma*100)-100 = Example:(2.2*100)-100=120 = 2.2 Gamma	78	01111000
24	18	Feature Support (no_DPMS, no_Active On/Very Low Power, RGB color display, Timing BLK 1,no_CTR)	0A	00001010	
<b>Vendor / Product</b>	25	19	Red/Green Low Bits (RxRy/GxGy)	15	00010101
	26	1A	Blue/White Low Bits (BxBY/WxWy)	D5	11010101
	27	1B	Red X Rx = 0.617	9E	10011110
	28	1C	Red Y Ry = 0.349	59	01011001
	29	1D	Green X Gx = 0.313	50	01010000
	30	1E	Green Y Gy = 0.595	98	10011000
	31	1F	Blue X Bx = 0.151	26	00100110
	32	20	Blue Y By = 0.056	0E	00001110
33	21	White X Wx = 0.313	50	01010000	
34	22	White Y Wy = 0.329	54	01010100	
<b>Established</b>	35	23	Established timing 1 (00h if not used)	00	00000000
	36	24	Established timing 2 (00h if not used)	00	00000000
	37	25	Manufacturer's timings (00h if not used)	00	00000000
<b>Standard Timing ID</b>	38	26	Standard timing ID1 (01h if not used)	01	00000001
	39	27	Standard timing ID1 (01h if not used)	01	00000001
	40	28	Standard timing ID2 (01h if not used)	01	00000001
	41	29	Standard timing ID2 (01h if not used)	01	00000001
	42	2A	Standard timing ID3 (01h if not used)	01	00000001
	43	2B	Standard timing ID3 (01h if not used)	01	00000001
	44	2C	Standard timing ID4 (01h if not used)	01	00000001
	45	2D	Standard timing ID4 (01h if not used)	01	00000001
	46	2E	Standard timing ID5 (01h if not used)	01	00000001
	47	2F	Standard timing ID5 (01h if not used)	01	00000001
	48	30	Standard timing ID6 (01h if not used)	01	00000001
	49	31	Standard timing ID6 (01h if not used)	01	00000001
	50	32	Standard timing ID7 (01h if not used)	01	00000001
	51	33	Standard timing ID7 (01h if not used)	01	00000001
	52	34	Standard timing ID8 (01h if not used)	01	00000001
	53	35	Standard timing ID8 (01h if not used)	01	00000001

Product Specification

APPENDIX A. Enhanced Extended Display Identification Data (EEDID™) 2/3

	Byte (Dec)	Byte (Hex)	Field Name and Comments	Value (Hex)	Value (Bin)
Timing Descriptor #1	54	36	Pixel Clock/10,000 (LSB) 138.5 MHz @ 59.9Hz	1A	00011010
	55	37	Pixel Clock/10,000 (MSB)	36	00110110
	56	38	Horizontal Active (lower 8 bits) 1920 Pixels	80	10000000
	57	39	Horizontal Blanking(Thp-HA) (lower 8 bits) 160 Pixels	A0	10100000
	58	3A	Horizontal Active / Horizontal Blanking(Thp-HA) (upper 4:4bits)	70	01110000
	59	3B	Vertical Avtive 1080 Lines	38	00111000
	60	3C	Vertical Blanking (Tvp-HA) (DE Blanking typ.for DE only panels) 31 Lines	1F	00011111
	61	3D	Vertical Active : Vertical Blanking (Tvp-HA) (upper 4:4bits)	40	01000000
	62	3E	Horizontal Sync. Offset (Thfp) 48 Pixels	30	00110000
	63	3F	Horizontal Sync Pulse Width (HSPW) 32 Pixels	20	00100000
	64	40	Vertical Sync Offset(Tvfp) : Sync Width (VSPW) 3 Lines : 5 Lines	35	00110101
	65	41	Horizontal Vertical Sync Offset/Width (upper 2bits)	00	00000000
	66	42	Horizontal Image Size (mm) 345 mm	59	01011001
	67	43	Vertical Image Size (mm) 194 mm	C2	11000010
68	44	Horizontal Image Size / Vertical Image Size	10	00010000	
69	45	Horizontal Border = 0 (Zero for Notebook LCD)	00	00000000	
70	46	Vertical Border = 0 (Zero for Notebook LCD)	00	00000000	
71	47	Non-Interlace, Normal display, no stereo, Digital Separate ( Vsync_NEG, Hsync_POS ), DE only note : LSB is set to '1' if panel is DE-timing only. H/V can be ignored.	1B	00011011	
Timing Descriptor #2	72	48	Pixel Clock/10,000 (LSB) 138.5 MHz @ 59.9Hz	1A	00011010
	73	49	Pixel Clock/10,000 (MSB)	36	00110110
	74	4A	Horizontal Active (lower 8 bits) 1920 Pixels	80	10000000
	75	4B	Horizontal Blanking(Thp-HA) (lower 8 bits) 160 Pixels	A0	10100000
	76	4C	Horizontal Active / Horizontal Blanking(Thp-HA) (upper 4:4bits)	70	01110000
	77	4D	Vertical Avtive 1080 Lines	38	00111000
	78	4E	Vertical Blanking (Tvp-HA) (DE Blanking typ.for DE only panels) 31 Lines	1F	00011111
	79	4F	Vertical Active : Vertical Blanking (Tvp-HA) (upper 4:4bits)	40	01000000
	80	50	Horizontal Sync. Offset (Thfp) 48 Pixels	30	00110000
	81	51	Horizontal Sync Pulse Width (HSPW) 32 Pixels	20	00100000
	82	52	Vertical Sync Offset(Tvfp) : Sync Width (VSPW) 3 Lines : 5 Lines	35	00110101
	83	53	Horizontal Vertical Sync Offset/Width (upper 2bits)	00	00000000
	84	54	Horizontal Image Size (mm) 345 mm	59	01011001
	85	55	Vertical Image Size (mm) 194 mm	C2	11000010
86	56	Horizontal Image Size / Vertical Image Size	10	00010000	
87	57	Horizontal Border = 0 (Zero for Notebook LCD)	00	00000000	
88	58	Vertical Border = 0 (Zero for Notebook LCD)	00	00000000	
89	59	Non-Interlace, Normal display, no stereo, Digital Separate ( Vsync_NEG, Hsync_POS ), DE only note : LSB is set to '1' if panel is DE-timing only. H/V can be ignored.	1B	00011011	
Timing Descriptor #3	90	5A	Flag	00	00000000
	91	5B	Flag	00	00000000
	92	5C	Flag	00	00000000
	93	5D	Data Type Tag : Alphanumeric Data String (ASCII String)	FE	11111110
	94	5E	Flag	00	00000000
	95	5F	Dell P/N 1st Character = C	43	01000011
	96	60	Dell P/N 2nd Character = 0	30	00110000
	97	61	Dell P/N 3rd Character = 8	38	00111000
	98	62	Dell P/N 4th Character = 8	38	00111000
	99	63	Dell P/N 5th Character = T	54	01010100
	100	64	EDID Revision Build Name = MP(X-Build) , Revision # = A00	80	10000000
	101	65	Manufacturer P/N = 1	31	00110001
	102	66	Manufacturer P/N = 5	35	00110101
	103	67	Manufacturer P/N = 6	36	00110110
104	68	Manufacturer P/N = W	57	01010111	
105	69	Manufacturer P/N = F	46	01000110	
106	6A	Manufacturer P/N = 1	31	00110001	
107	6B	Manufacturer P/N(If<13 char--> 0Ah, then terminate with ASC II	0A	00001010	

**APPENDIX A. Enhanced Extended Display Identification Data (EEDID™) 3/3**

	Byte (Dec)	Byte (Hex)	Field Name and Comments	Value (Hex)	Value (Bin)
<b>Timing Descriptor #4</b>	108	6C	Flag	00	00000000
	109	6D	Flag	00	00000000
	110	6E	Flag	00	00000000
	111	6F	Data Type Tag : Descriptor Defined by manufacturer	00	00000000
	112	70	Flag	00	00000000
	113	71	SMBUS Value(Step #1) = 10 nits	00	00000000
	114	72	SMBUS Value(Step #2) = 17 nits	00	00000000
	115	73	SMBUS Value(Step #3) = 24 nits	00	00000000
	116	74	SMBUS Value(Step #4) = 30 nits	00	00000000
	117	75	SMBUS Value(Step #5) = 60 nits	00	00000000
	118	76	SMBUS Value(Step #6) = 100 nits	00	00000000
	119	77	SMBUS Value(Step #7) = 160 nits	00	00000000
	120	78	SMBUS Value(Step #8) = 220 nits (Typically = FFh, Max nits)	00	00000000
	121	79	Dual LVDS, No RTC, No VIC support	02	00000010
<b>Checksum</b>	122	7A	BIST support	01	00000001
	123	7B	(If<13 char--> 0Ah, then terminate with ASC II code 0Ah,set remaining char = 20h)	0A	00001010
	124	7C	(If<13 char--> 0Ah, then terminate with ASC II code 0Ah,set remaining char = 20h)	20	00100000
	125	7D	(If<13 char--> 0Ah, then terminate with ASC II code 0Ah,set remaining char = 20h)	20	00100000
	126	7E	Extension flag (# of optional 128 panel ID extension block to follow, Typ = 0)	00	00000000
	127	7F	Check Sum (The 1-byte sum of all 128 bytes in this panel ID block shall = 0)	D1	11010001