

STERN
Ghostbusters (GB) 2016

“Proton Gun” Mod (2021)

The Ghostbuster “Proton Gun” mod is hand crafted in Australia by a GB owner for all the other GB owners around the world that love their game and want to finally complete the game. Stern made allowance for Proton Guns but never implemented them into the game. Now you can add ball interactive mechs to your GB Pro / Premium / LE.



Thank you for your support and I hope you will enjoy this mod for many years to come

Proudly Designed and Manufactured by



www.swinks.com.au

Manual Rev-2 (11-11-21)

1 of 51

Page 3	1. Tools and Safety Notes
Page 4-5	2. The Myth
Page 6-8	3. The “Proton Gun” Kit
Page 9-10	4. What Mod Options Are There
Page 11-21	5. Fitting the Coin Door Parts
Page 22-23	6. Routing the Power Supply and Foot Switch Cables
Page 24	7. Removing the Playfield Plugs
Page 25-26	8. Dismantling Proton Guns for Assembly
Page 27	9. Fitting the RHS Proton Mech
Page 28	10. Fitting the LHS Proton Mech
Page 29-30	11. Securing Cabling to Playfield Underside
Page 31	12. Fitting The Plastic Lifter
Page 32	13. Fitting Proton Gun Lights & Cabling
Page 33-37	14. Fitting Proton Guns to Mechs
Page 38-40	15. Connecting Cabling to Coin Door Assembly
Page 41	16. Understanding the Proton Gun Servo’s
Page 42-45	17. Hook Up / Power Up & Tune Up Process
Page 46	18. Using the Proton Gun Mod
Page 47	19. Modifying the Proton Gun Mod
Page 48-49	20. Trouble Shooting Possible Issues
Page 50	21. Historical Data - Proton Gun Revisions
Page 50	22. Assembly Drawings
Page 51	Return Policy and Disclaimers

Note: These instructions are specific for the 2021 released Proton Gun Mod v2

1. Tools and Safety Notes

Tools necessary to install the mod

1 x jeweller Phillips screwdriver (is not provided)

1 x 5/16" socket driver (is not provided)

1 x adjustable wrench / spanner / shifter (called different things in different countries - is not provided)

1 x 2.5mm metric allen key (provided in the kit)

1 x 2.0mm metric allen key (provided in the kit)

1 x 1.5mm metric allen key (provided in the kit)



SAFETY NOTES:

Make sure that your machine is powered off and the power cord running from your machine to the wall outlet has been turned off / disconnected to remove all risk of electrocution.

Read through these instructions carefully & completely before attempting the installation of this pinball mod enhancement. Although you may know your machine inside and out, there are a few things to consider before proceeding blindly.

2. The Myth

This is one of these mods where some people have sold el-wire kits and stated that is what Stern had intended to supply - this is a myth and is not true. This is one of the rare games in which Stern were going to supply the game with a Proton Gun feature but then never did due to cost, but still allowed the Pro / Premium / LE to still have the holes in the playfield for the feature.

The details are vague but based on sneak release images / videos and a brief chat with the designer Trudeau in 2016 the original mechs were largish and had large lit up proton beams that moved in to the centre of the playfield and you couldn't cross the streams. I dare say the video mode replaced the intended mechs. Here are the concept images of what was originally planned.

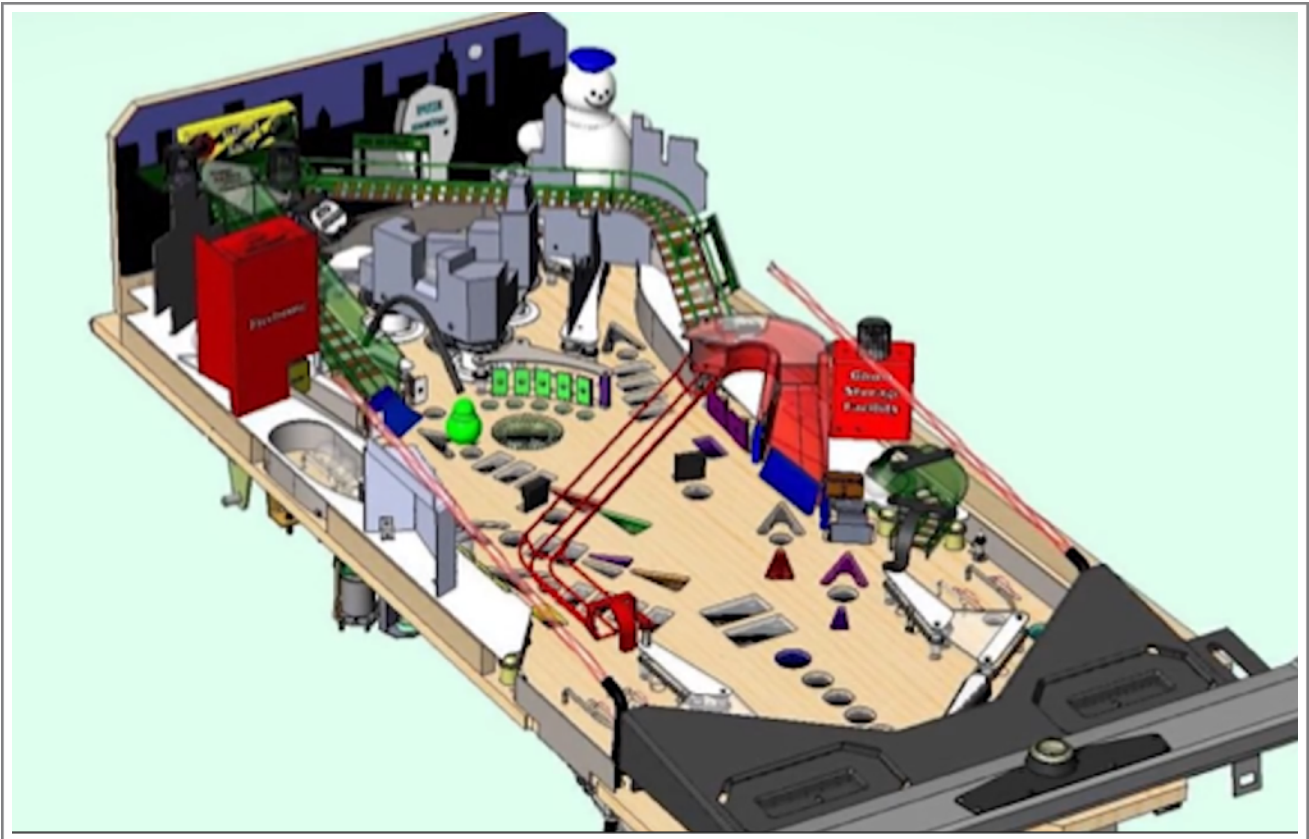

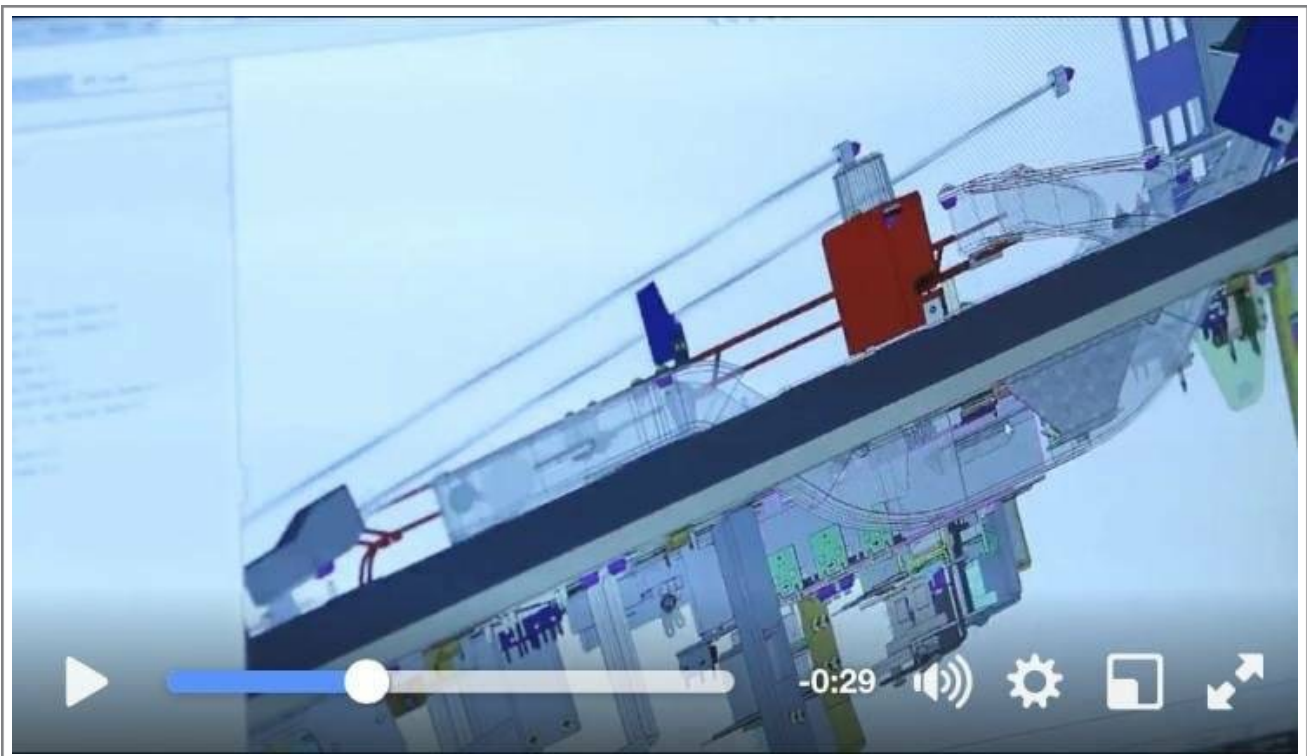
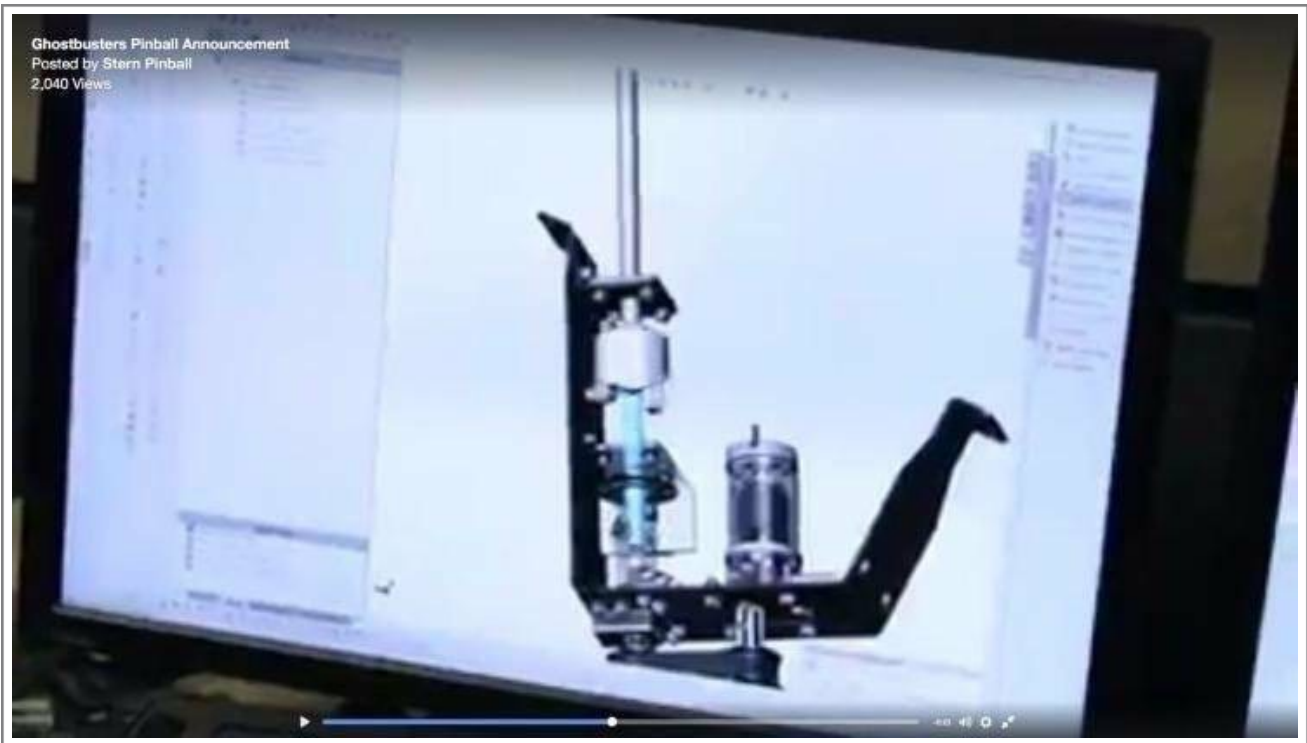

3. The “Proton Gun” Kit

This what the mod (v2a) looks like in it's non installed but connected state though will be packaged into smaller kits.

- 1 x LHS Playfield Mech and Gun
- 1 x RHS Playfield Mech and Gun
- 1 x Coin Door Assembly
- 1 x Wiring Kit (servo and lighting) between Mechs / Gun to the Coin Door Assembly
- 1 x Foot Switch (connected to door panel)
- 1 x 5vdc Power Brick (connect to door panel) **excluding wall power lead**
- 1 x Plastic Lifter / set of Allen keys / Screws to fasten mechs to playfield
- 10 x cable ties and 1metre of cable spiral wrap

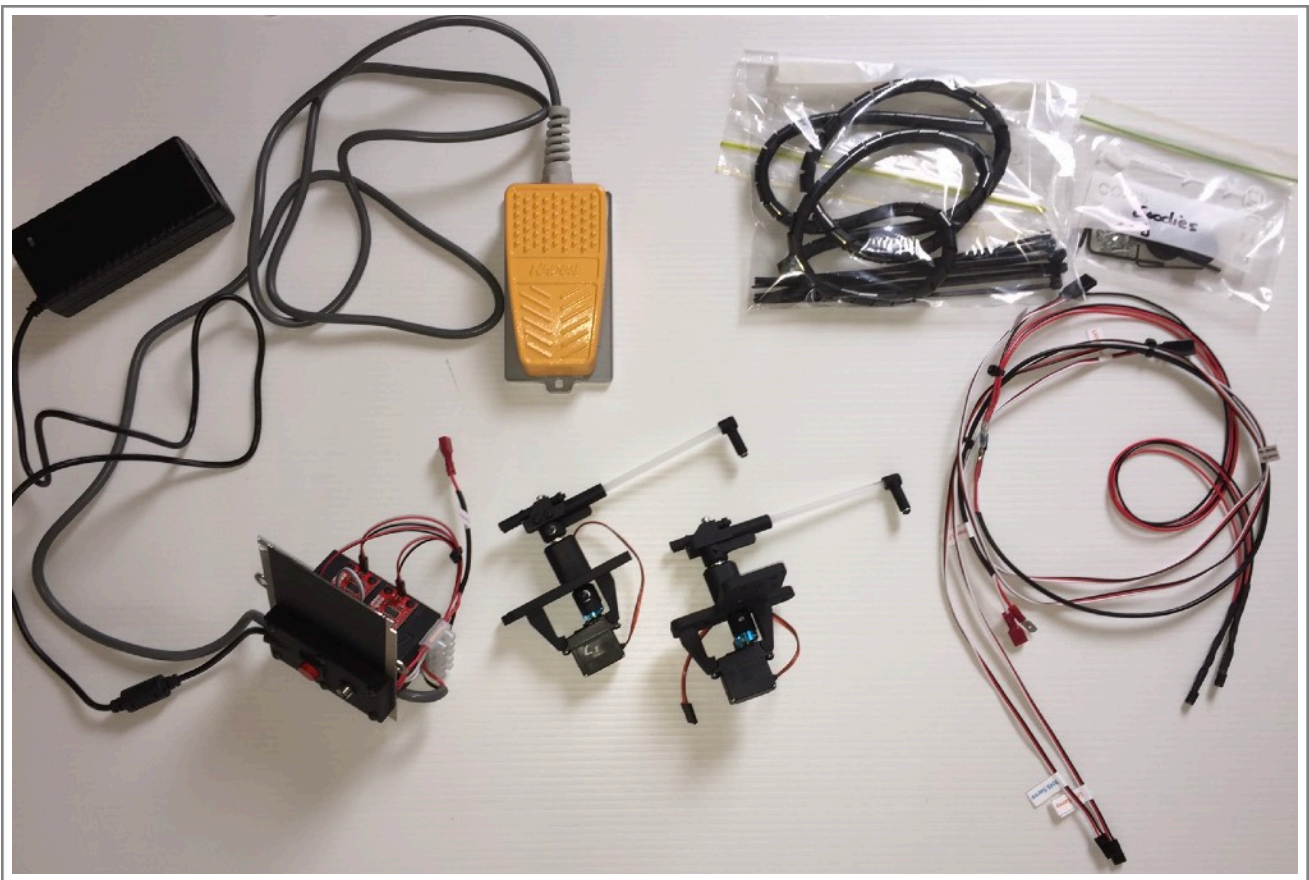

Note 1: The Pedal Colour will vary - Orange or Grey depending on what you ordered.

Note 2: The Coin Door plate will vary - allow for cables coming through the coin door or through the cabinet base.

Note 3: The lead from the power brick to the wall will need to be sourced by the customer outside of Australia - my apologies. As I buy these in bulk to get a reasonable price but there is no option for a USA lead so I would have to order from overseas and then ship to you which is adding weight & cost. See the next page of the part you need to buy at an electronics shop / bay or Amazon. Should be around the \$7-10 cost.

This what the mod (**v2b**) looks like in it's non installed but connected state though will be packaged into smaller kits.

- 1 x LHS Playfield Mech and Gun
- 1 x RHS Playfield Mech and Gun
- 1 x Coin Door Assembly
- 1 x Wiring Kit (servo and lighting) between Mechs / Gun to the Coin Door Assembly
- 1 x Foot Switch
- 1 x 5vdc Power Brick **excluding wall power lead**
- 1 x Plastic Lifter / set of Allen keys / Screws to fasten mechs to playfield / 2 x through cabinet bushes
- 10 x cable ties and 1metre of cable spiral wrap

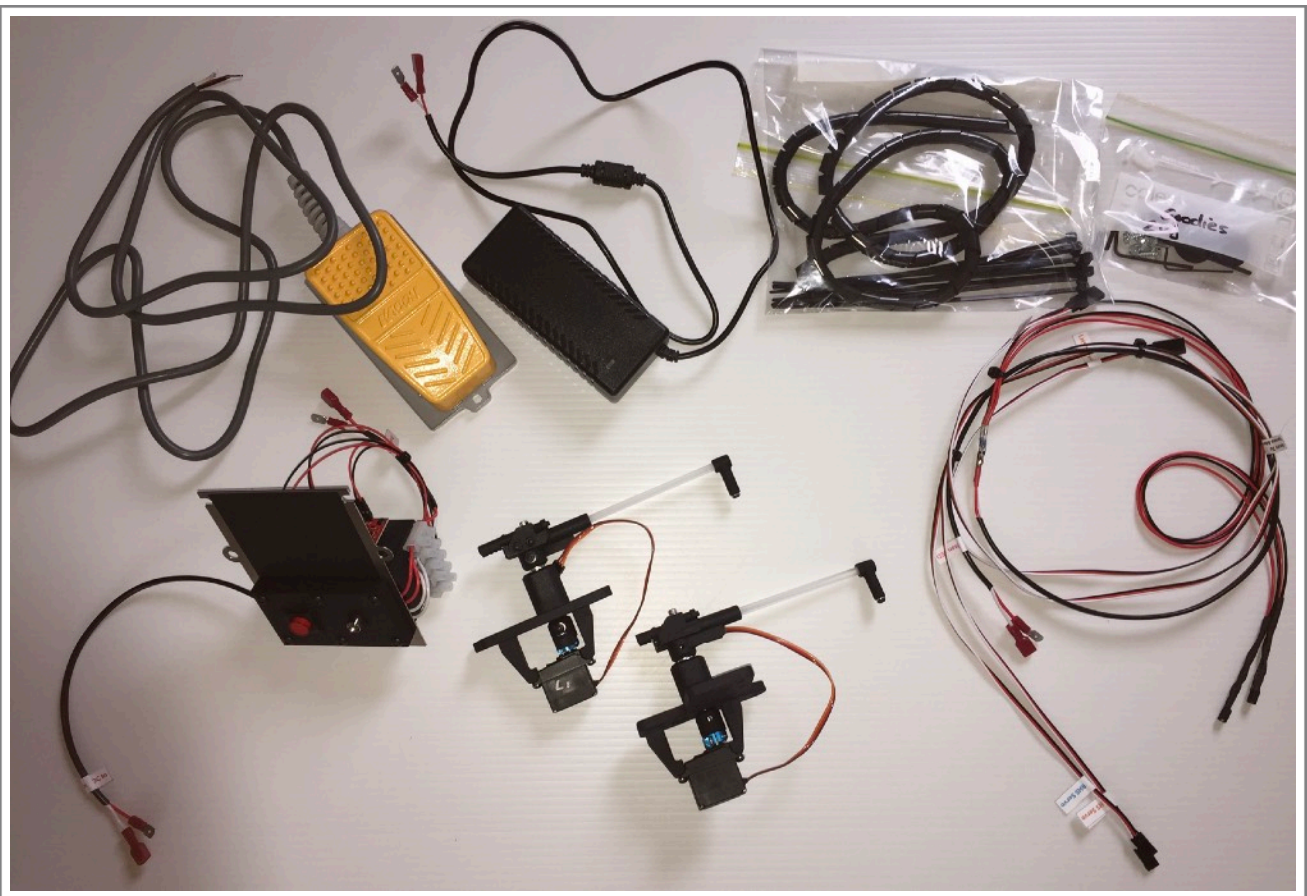

Note 1: The Pedal Colour will vary - Orange or Grey depending on what you ordered.

Note 2: The Coin Door plate will vary - allow for cables coming through the coin door or through the cabinet base.

Note 3: The lead from the power brick to the wall will need to be sourced by the customer outside of Australia - my apologies. As I buy these in bulk to get a reasonable price but there is no option for a USA lead so I would have to order from overseas and then ship to you which is adding weight & cost. See the next page of the part you need to buy at an electronics shop / bay or Amazon. Should be around the \$7-10 cost.

If you are outside of Australia you will need to purchase this lead for the supplied power brick. For example in the US these can be found at Walmart starting from \$6.95.



4. What Mod Options Are There

One option is the foot switch to activate the Proton Guns available in a Yellow (Light Orange) or Grey. These are hard to get at a good price so keep minimal stock so if you are wanting a mod let me know your colour preference asap.



The next option is deciding the way the cabling (power and foot switch) comes into the cabinet

1. The mod cabling passing through the coin door = **v2a**:

Pro's - no permanent alterations to your cabinet

Con's - the cabling over time could possibly damage / mark your cabinet decal

2. The mod cabling passing through a new drilled hole in the front left corner of your cabinet base = **v2b**:

Pro's - cables are not seen as they can be tucked in the inside edge of the pinball leg and restrained inside the front left pinball leg with cable anchors

Con's - permanent alteration to the cabinet - on the positive side I will provide a STL file for a 3D printed part to plug up the hole if you remove the mod from your game but will come with a 2 part cable bung.

When you order you need to tell me what option you want so I can order the correct professionally 3D printed parts.

Cables coming through the front looks like this:



Cables coming through the base looks like this:



Note: this does require drilling a hole in the cabinet base near the front left corner. This is described later in the manual.

5. Fitting the Coin Door Parts

There are 2 versions of Front Coin Door Panel:

V2a - cables pass through the front of the coin door.

V2b - cables pass through the cabinet base - you need to drill a hole.

Stern sends games all over the world including Ghostbusters but strangely does not supply the game with a standardised door all over the world.

Australia and New Zealand gets a Coin Door like this, which Pinball Life sells called a SAM / Whitestar Door which has a small knock out panel on the left hand side:

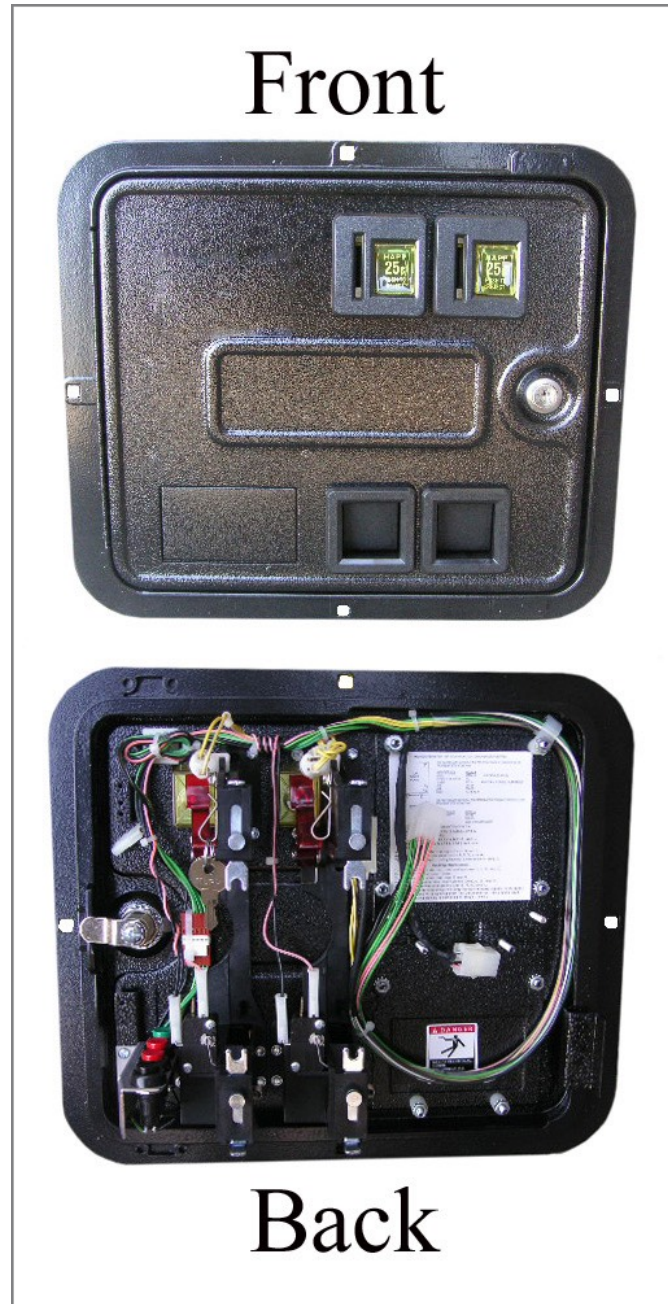

USA / Canada and Italy gets a Coin Door like this, which Pinball Life sells called a US Spike 2 Door which has a large knock panel on the left hand side:

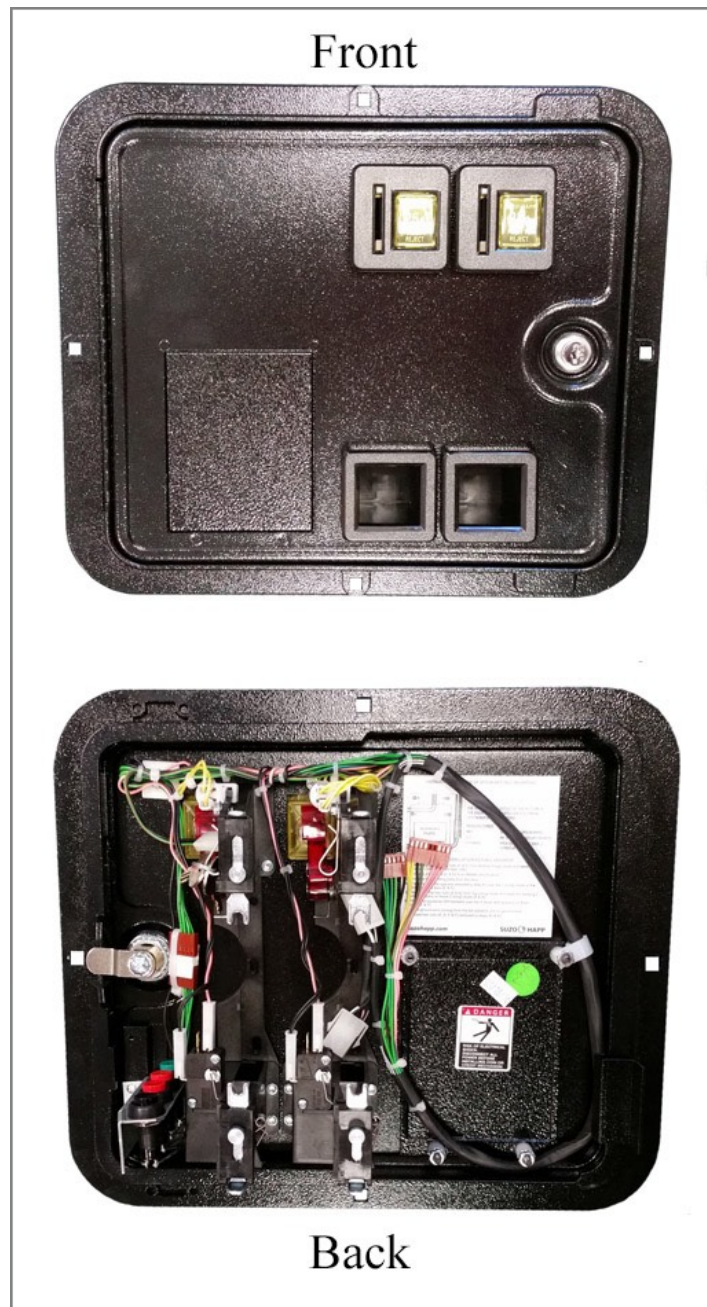

Sadly parts of Europe get a different door again that does not have a knockout panel so this mod will not just bolt in. For people interested in this mod who are in Europe they need to check the above and need to customise there door or can buy a replacement door or just the door skin (fairly affordably) from Pinball Life and then follow the next steps.

The following instructions are for fitting the V2a version

You will need to locate your Coin Door Assembly which looks like this which is made up of the power brick, foot pedal and the coin door plate assembly:



The Swinks replacement plate is universal and suits games with a large and small knockout panel. The following photos refer to my Australian version.

Coin door viewed from the outside:



Coin door viewed from the inside:



Remove the 6 x spacers / washers and nuts and original plate to expose the hole in the coin door. Then feed the power brick through the hole followed by the foot switch.



Then feed the foot switch through the coin door hole.



Then you will need to remove the front cover to be able to mount the plate to the door - this is because of the exiting cables make it difficult to place the plate over the existing bolts. For the v2 you will need to remove all 6 bolts with the supplied Allen key. Then allow the cables and plate to fit properly and then fasten the plate in place followed by re-securing the face plate.



Slide the plate over the bolts and then reattach the spacers / washers / nuts and nip up.

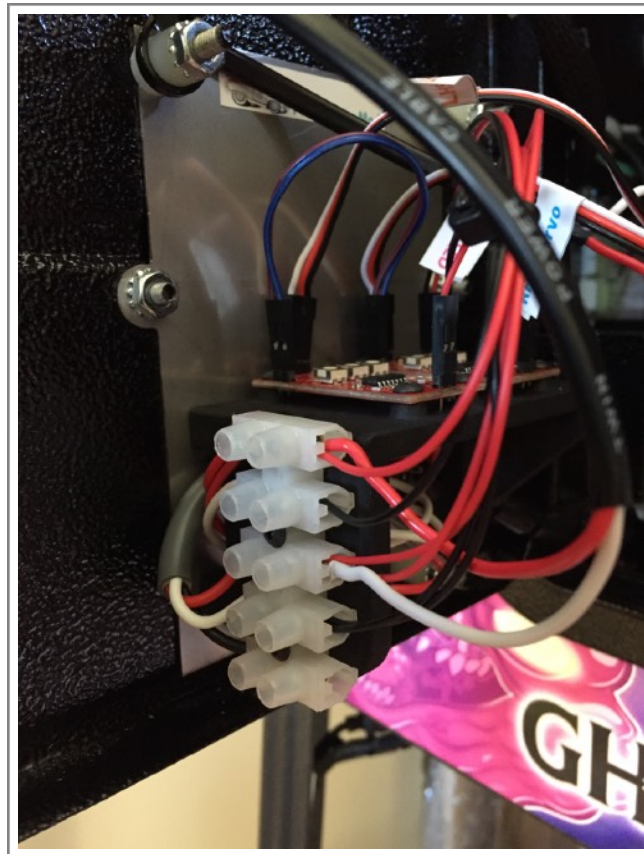

Then fasten the front panel to the plate as you found it.



The following instructions are for fitting the V2b version

You will need to locate your Coin Door Assembly and Foot Switch / Power Brick Assembly - which are 2 different separate components which will look like these from you mod kit:

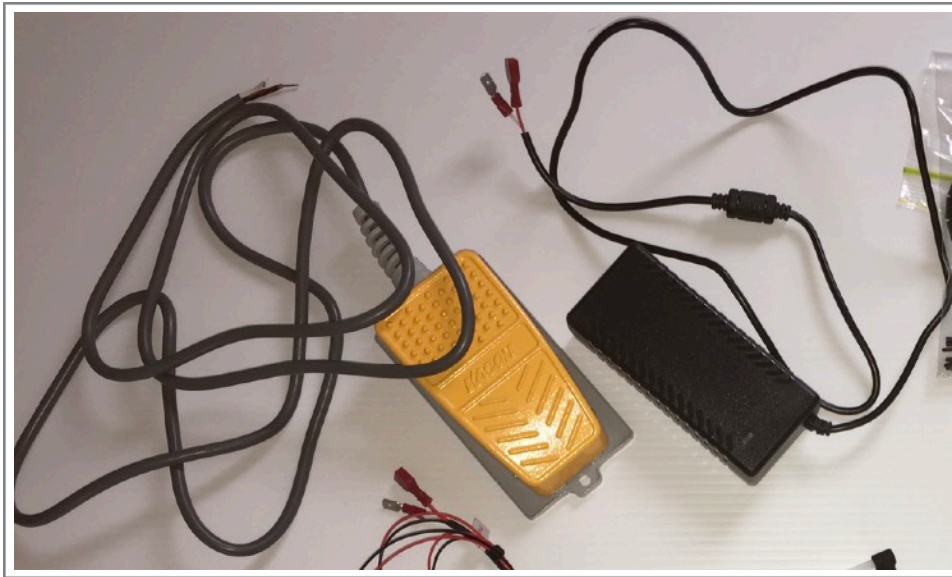

Then you will need to drill a 1/2" / 12.7mm or 13mm hole into your cabinet near the front left corner from underneath going upwards. But start slowly with a small drill 3mm and then about a 6mm and lastly the final size detailed above. Also find some scrap timber and place inside the cabinet and either weigh it down or have a friend / partner apply pressure so when the drill runs through the base it will continue a little into the scrap timber - giving you a nice clean hole - **BIG NOTE** - make sure that the friend / partner does not put their hand in the range of the drill coming up - don't want 2 holes eeekkk.

The hole is 40mm in from both edges as per below:



The drilled hole will look like this - underside & top side (though I forgot the scrap timber):

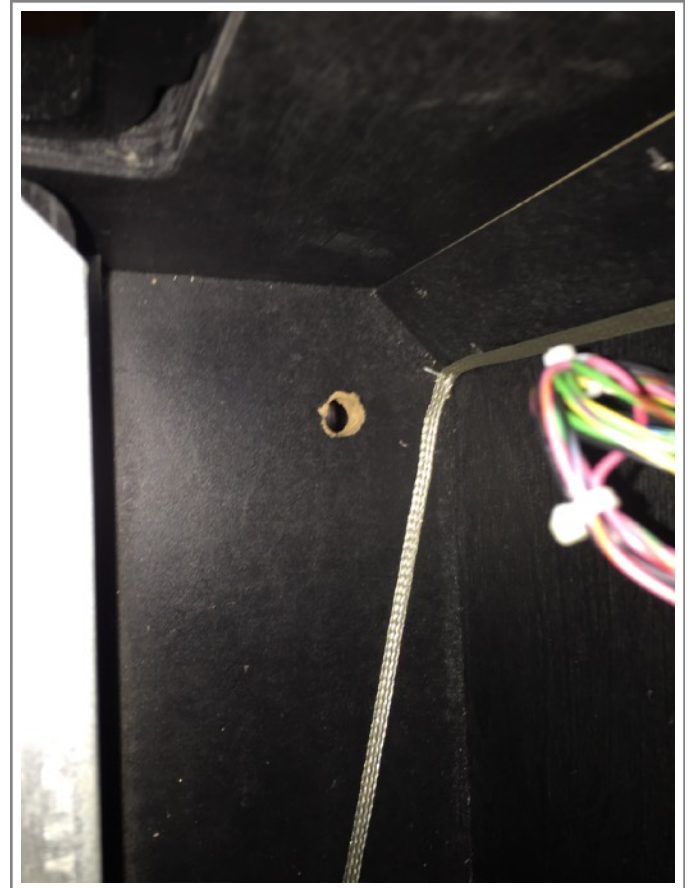

Then with the **v2b** you will get 2 bushes which fit in from the top and bottom and you can screw down with a bolt right through or with small screws - it is your choice. The bushes look like this in the installed state - if you are using bolts use approx M3 x 25mm or 1 inch with some nuts. This will make the cabinet look finished and professional and not a hack.

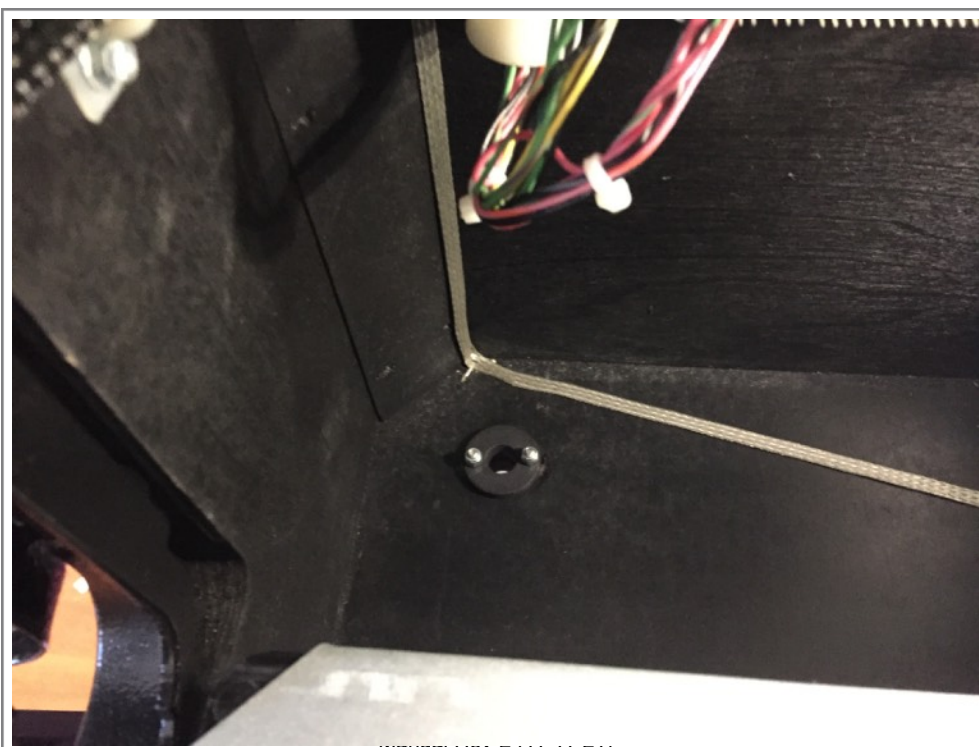

Now you need to install the power brick cable and foot switch cable. The hole size in the bushes is neat on purpose, so follow this procedure otherwise you will curse me and say it isn't possible.

- insert the female terminal from under the cabinet through to the inside of the cabinet then the male terminal.
- Now insert the foot switch wires and cable through the bush - it will be neat but this is a good thing as then nothing falls out too easily.
- The power cable can only go up to the point of the bulky component on the lead limiting the distance it can pass into the cabinet.

Allow a little bit of play in the cables between the bushes and coin door knockout panel making sure you can fully open the door. Then feed excess cable back through the bush outside the cabinet base - do a rough check to make sure the foot switch is in the desired location between the legs as well. Secure the cables with a cable tie on the inside cabinet just above the bush to limit the amount it can drop out.



Now remove your door knockout panel - for the US guys your panel is larger but uses the same bolts.



Now locate your V2b Coin Door Kit and fasten the foot switch cable to the terminal strip as per diagram on the next page. Then fasten the coin door panel to the coin door with the existing coin door bolts - the V2b kit as it just slides through.

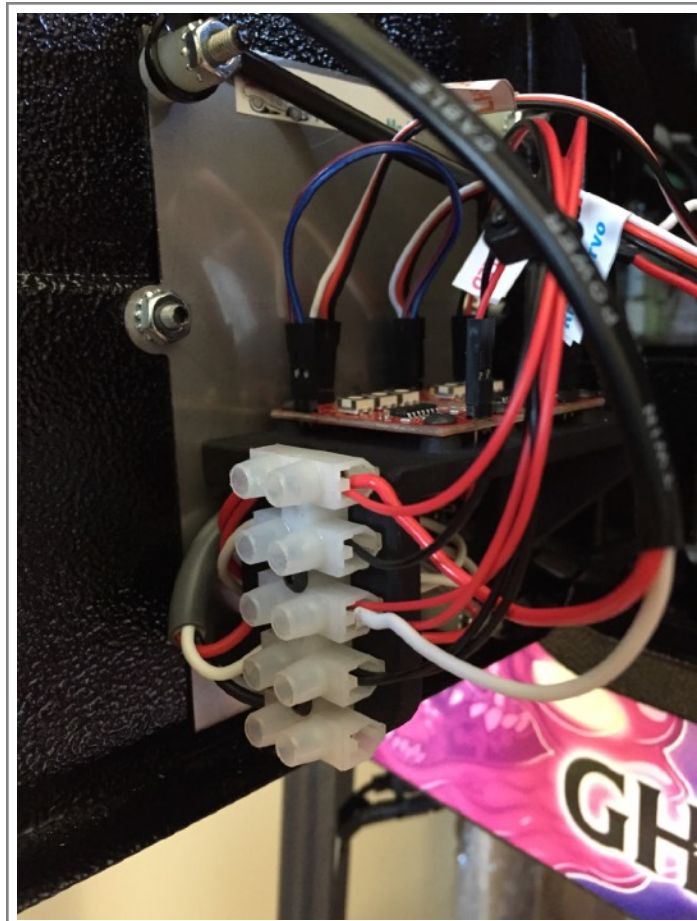

Now connect the power wires from the coin door assembly to the cable coming through the cabinet.

Below is the Terminal block wiring diagram for fitting any cables and use as a guide if you need to dismantle and re-assemble anything.

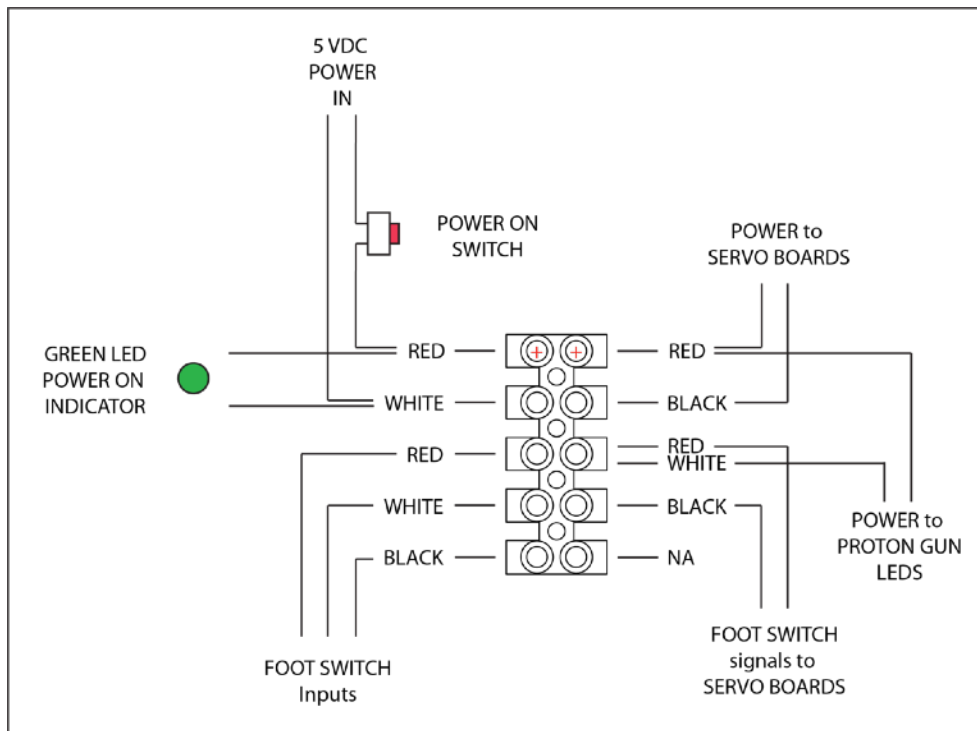

Then wiring diagram for the servo boards.

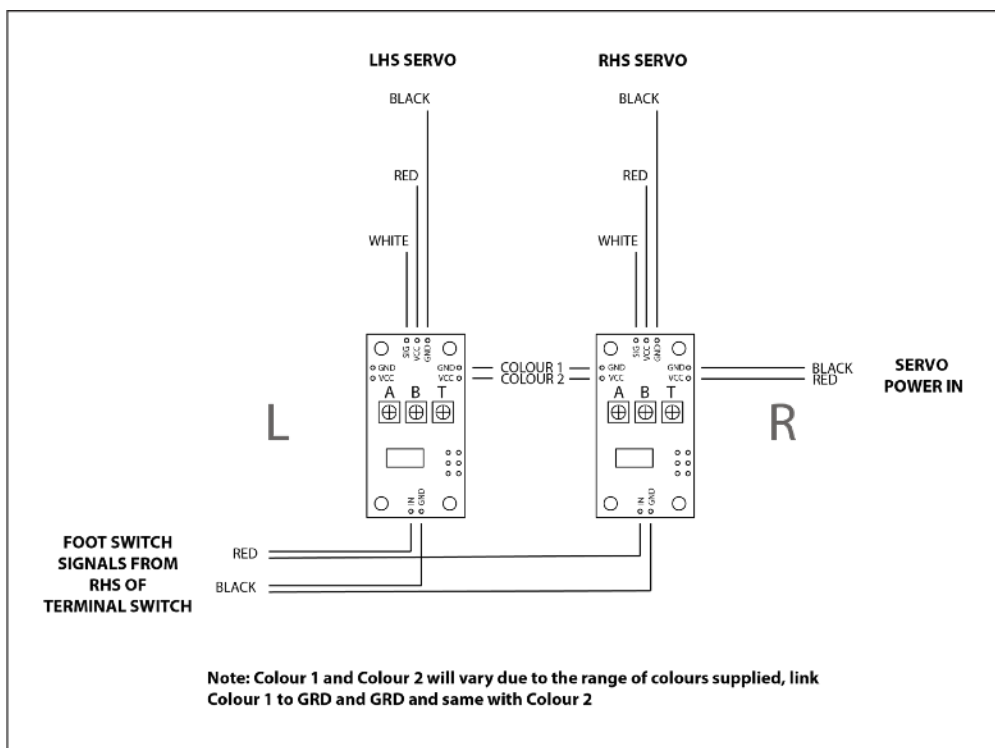

6. Securing the Power Supply and Foot Switch Cables

Regardless of the cables dropping from the coin door or from the cabinet base I recommend securing 2 cable anchor squares (supplied) to the inside of the left leg and then securing to the leg levelling bolt. This will protect the cables fitted to the door or under the cabinet.



Install the 2 x cable anchor squares to the inside of the pinball leg and now with the supplied spiral wrap start at the coin door or under the cabinet secure the 2 x cables together and fasten to the 2 x fitted cable anchor squares and then a 3rd cable tie to the levelling bolt.



7. Removing the Playfield Plugs

Lift the playfield and locate on to it's service brackets / posts as you will need to access the plugs from both sides of the playfield.

This is the left hand plug and the right side is the same setup.



Put a spanner onto the nut underneath and screw from the top and remove the bung and small plastic first and then remove the plate from the playfield and reassemble as a kit and store in your games goodie bag. The hex screw that fastens the plate to the playfield can be reused for the new mechs but designed so it is not required so store in the goodie bag as well.

8. Dismantling Proton Guns for Assembly

Before installing the LHS & RHS mechs you will have to remove the guns. Your sub-assemblies will look like this. The narrow mech is the LHS and RHS has the large wing on it with the Swinks logo and v2 engraved in it.

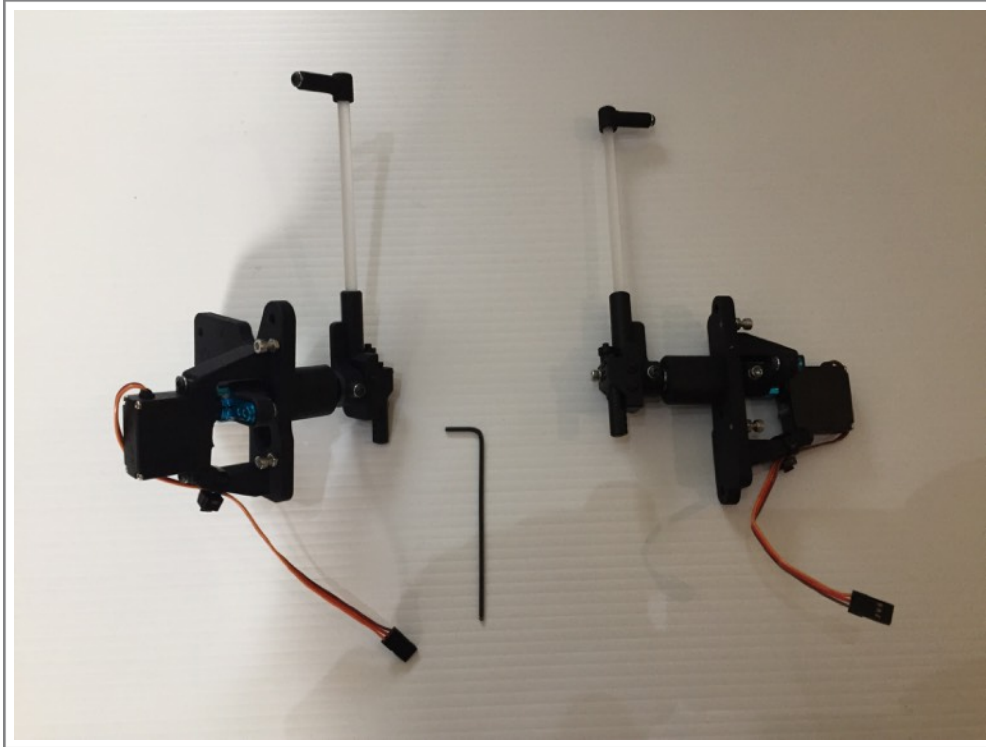

Using the supplied Allen Key locate the black bolt and loosen a couple of turns and then the gun will lift off the shaft. The gun is specific to the side as when installed the stream needs to tuck against the playfield side otherwise the ball can not pass by.

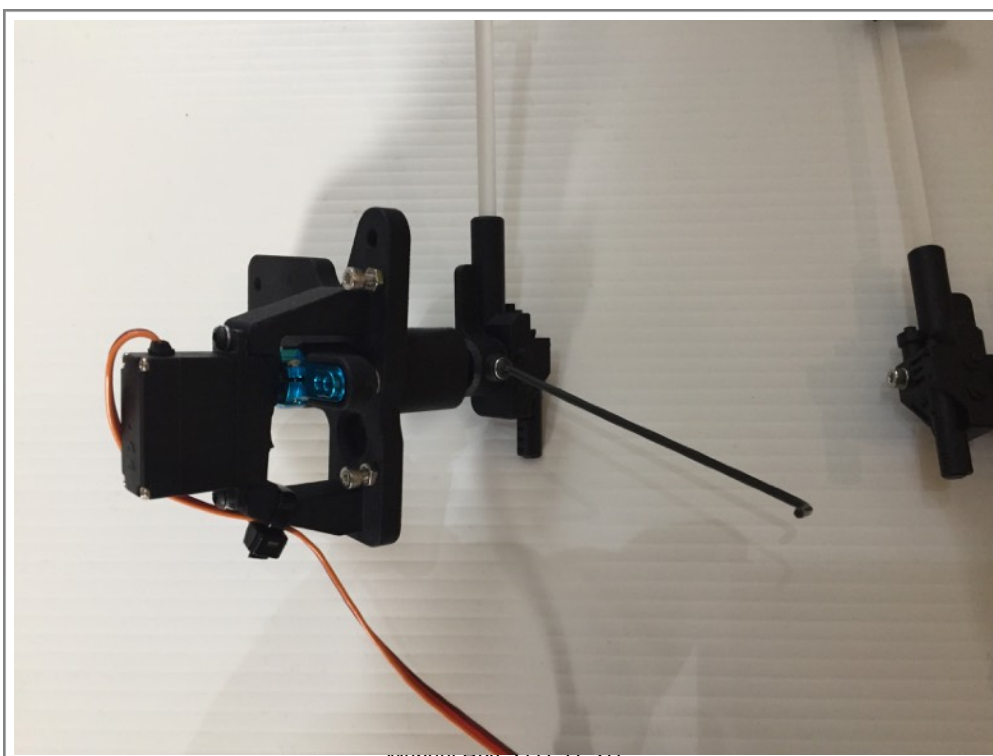

Perform this to both mechs and ensure not to discard the washers (*there is actually 2 per side*) as they are important for reassembly. Also take note of the roller bearings as they might be a neat to slightly loose fit so you don't want to lose them.

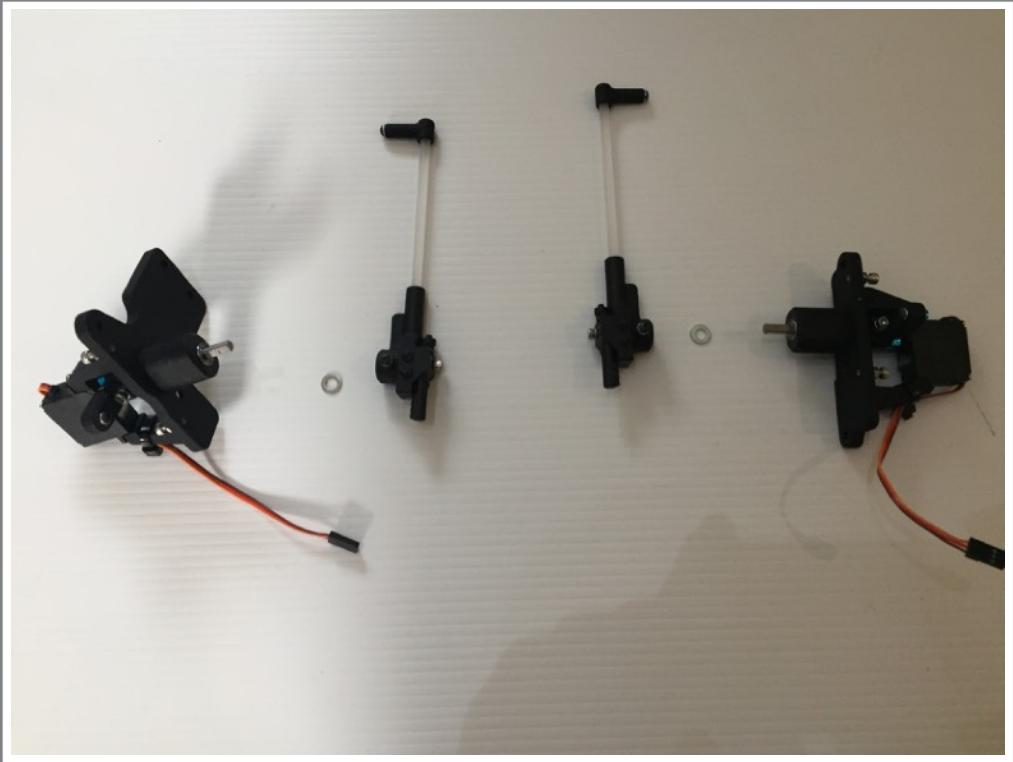

9. Fitting the RHS Proton Mech

Once the bungs and plates are removed it will look like this. Note: mine has 2 extra screw holes in the playfield from already installing the mech.

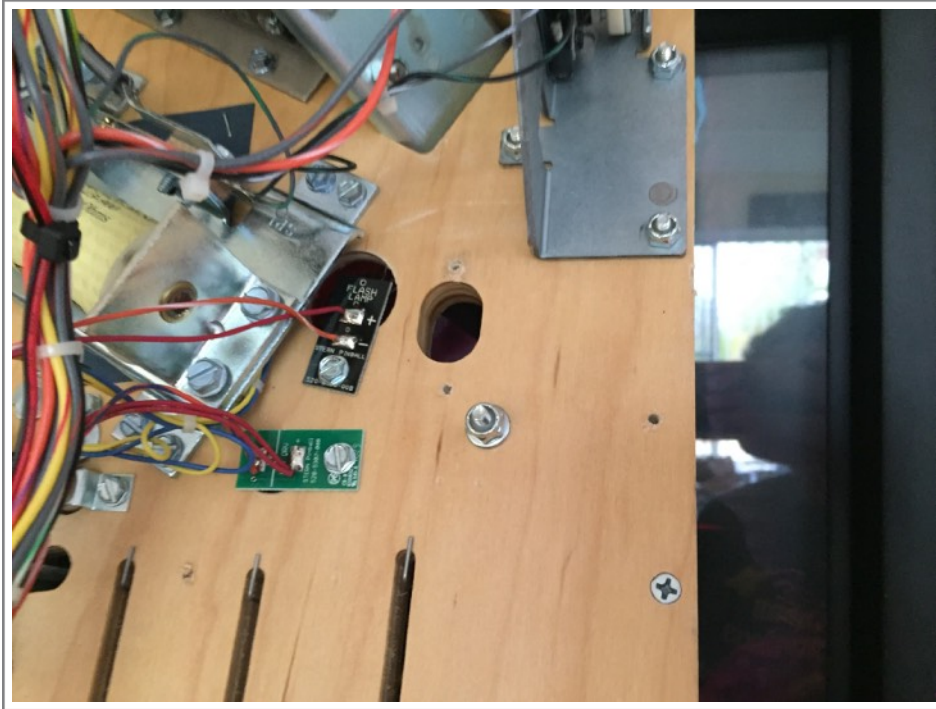

The RHS mech has the Swinks Logo and version number engraved into it. Pass the mech into the playfield hole and then hand drive the 3 supplied playfield hex screws through the mech holes. Make sure to keep it square. There is an extra hole which picks up the original plate mount screw / hole, but to use this you need to dismantle the servo and mech and re-assemble would not be the easiest while fitted to the playfield so only use if you want that extra piece of mind. If you do use the shorter original screw.

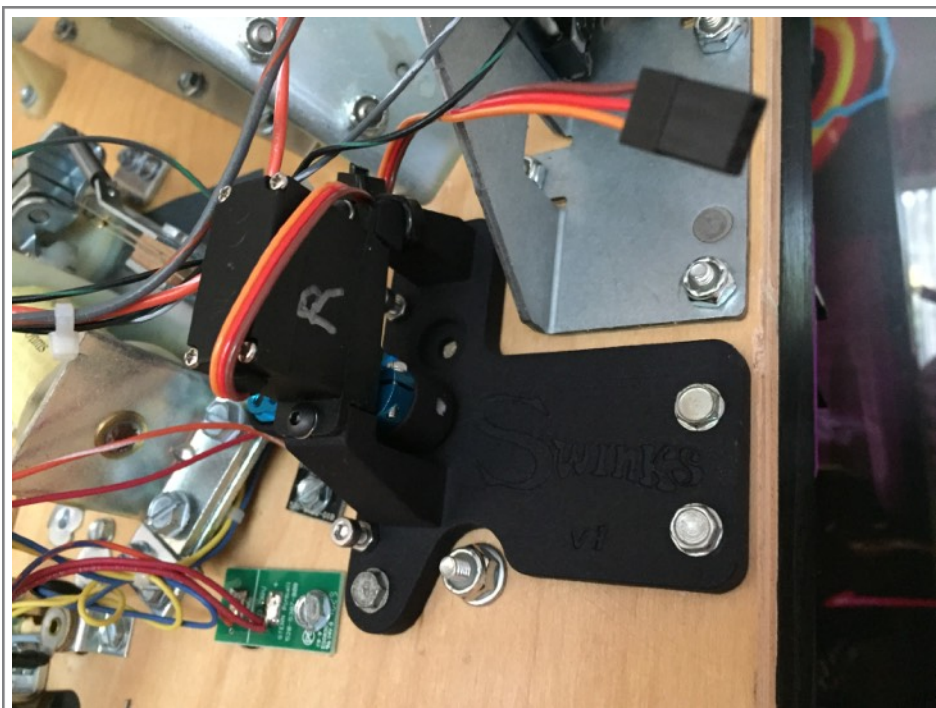

10. Fitting the LHS Proton Mech

Repeat the process for the LHS and apologies I do not have a before mech install photo but very similar to the RHS but there is less space and more of a slender space to work with.

Pass the mech into the playfield hole and then hand drive the 2 supplied playfield hex screws through the mech holes. Make sure to keep it square. There is an extra hole which picks up the original plate mount screw / hole, but to use this you need to dismantle the servo and mech and re-assemble would not be the easiest while fitted to the playfield so only use if you want that extra piece of mind.



11. Securing Cabling to Playfield Underside

Once the mechs are installed you will need to secure the 2 extension servo wires on both sides routing to the top / front of the playfield as shown.

When securing and fastening put a small loop (50mm / 2 Inch) in near the mech to the main cable bundle on either side to allow a little bit of slack incase you need to service the mech. Secure in 2 spots up to the centre of the playfield front near the big cut out for both sides. The cable starts off as brown / red / orange from the servo and converts to black / red / white. Ensure the colours continue on as follows:

Brown = Black

Red = Red

Orange = White

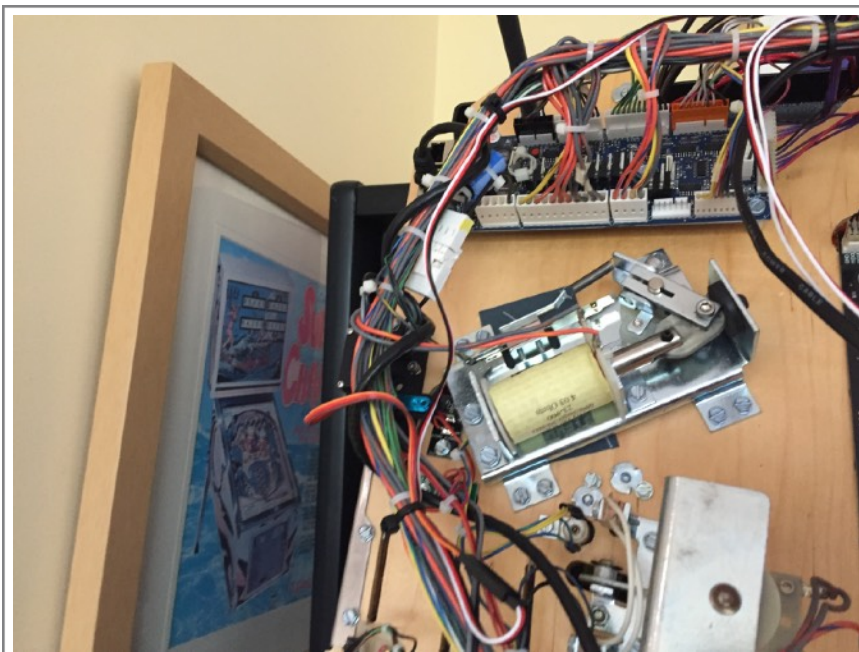
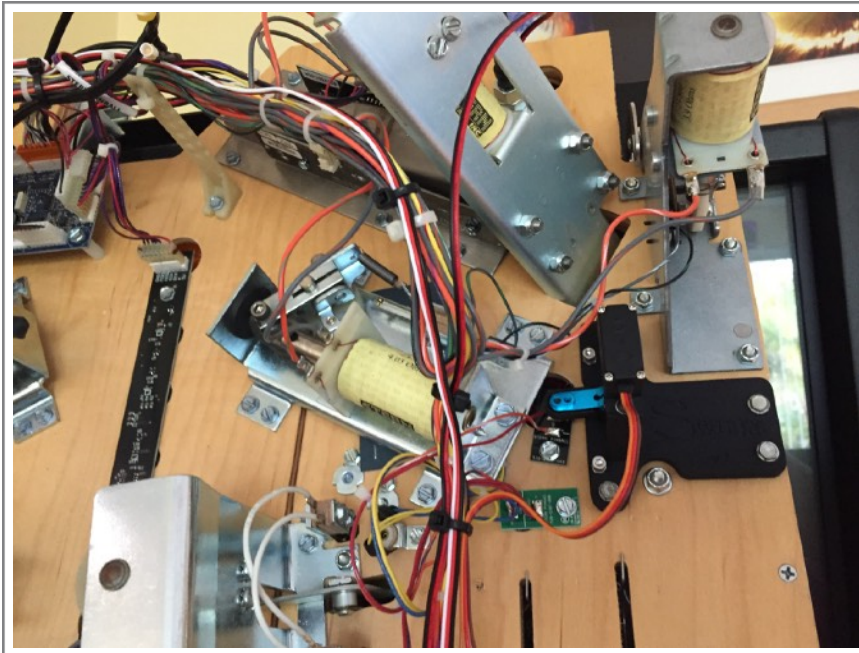

Fasten both black / red / white and the proton led cable in the centre of the playfield. The cable bundle is already bundled and it will have a label - **Secure To Harness Here** - this is your indicator of where to mount to the playfield harness in the middle.

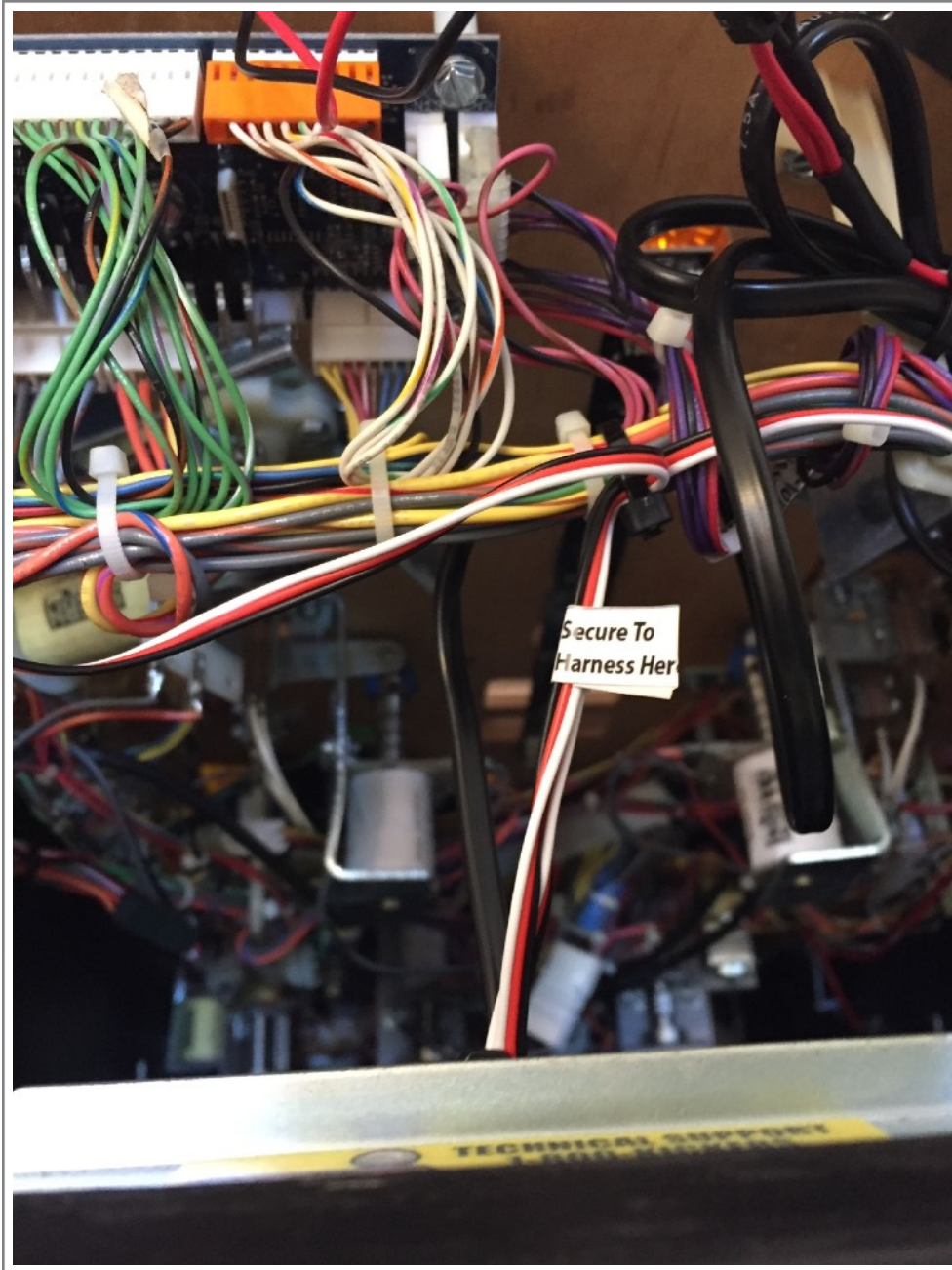

Then drop the 3 x cables down awchich will already be bundled together ready for when the playfield is lowered. Now the playfield can be lowered - ensure the 3 cables do not get caught up with anything and at risk of being pinched.

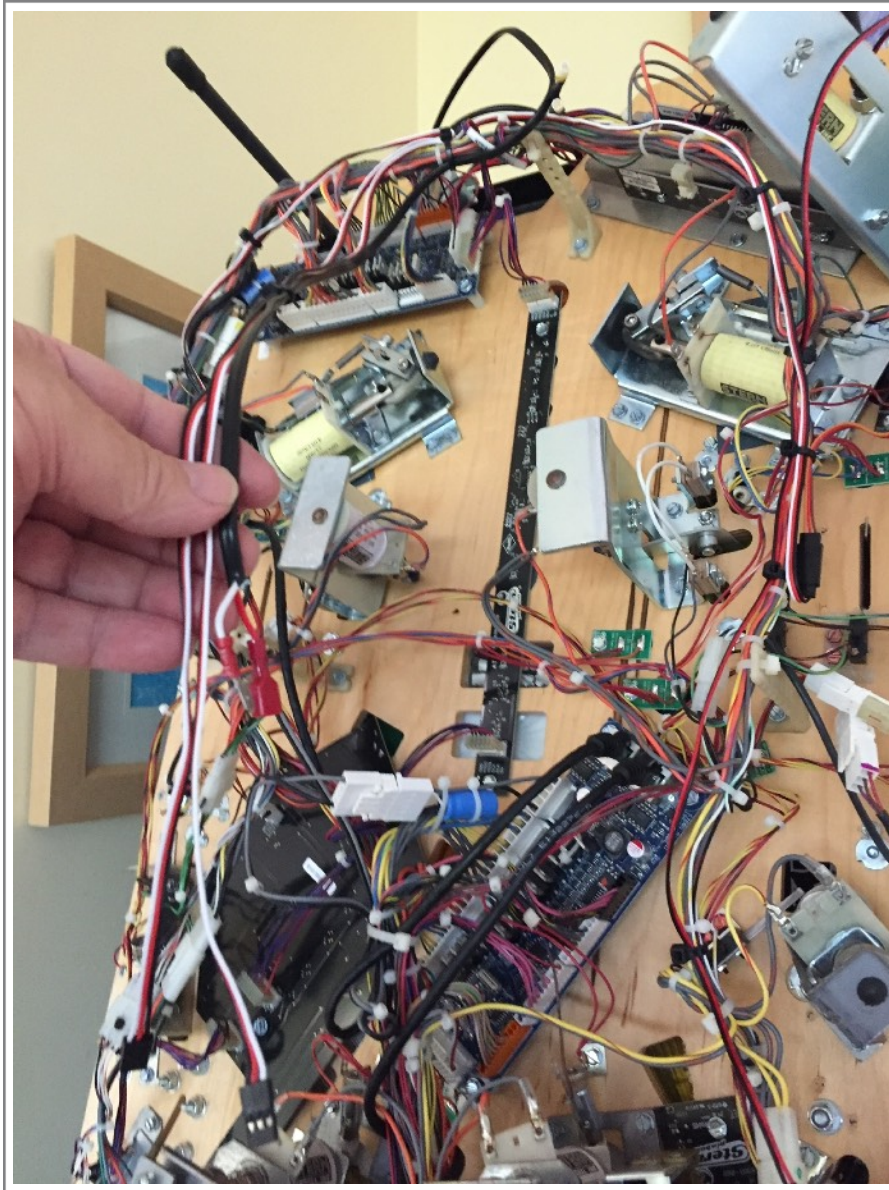

12. Fitting The Plastic Lifter

The RHS Proton Gun rubs and can get jammed on the stainless steel bracket / plastic near the RHS out lane so this is a simple slide on part that slides on to the stainless steel rail with the bevelled edge facing the top of the playfield. Slightly lift the plastic and push the spacer up until it rests against the plastic matching bevelled edge and now you have clearance and no rubbing / jamming issues.



13. Fitting Proton Gun Lights & Cabling

To fit the lighting to the proton guns the apron has to be removed. For the Pro it is a plastic apron and to remove is very easy. Simply remove the game cards and underneath are 2 nylon nuts - remove these and then lift the apron off. For the LE you will have a steel folded apron which will have different mounting which I believe is 2 screws at the very front near the playfield hangers.



Then route the lighting lead with the 2 LEDs via the large cut way at the front of the playfield. The LED's are already fitted to a bulb gun adaptor and the LED's simply push in and held with friction. If they are a fraction loose cut a small piece of masking tape and wrap around the bulb adaptor and insert into both guns. Refer to the next step for gun assembly.

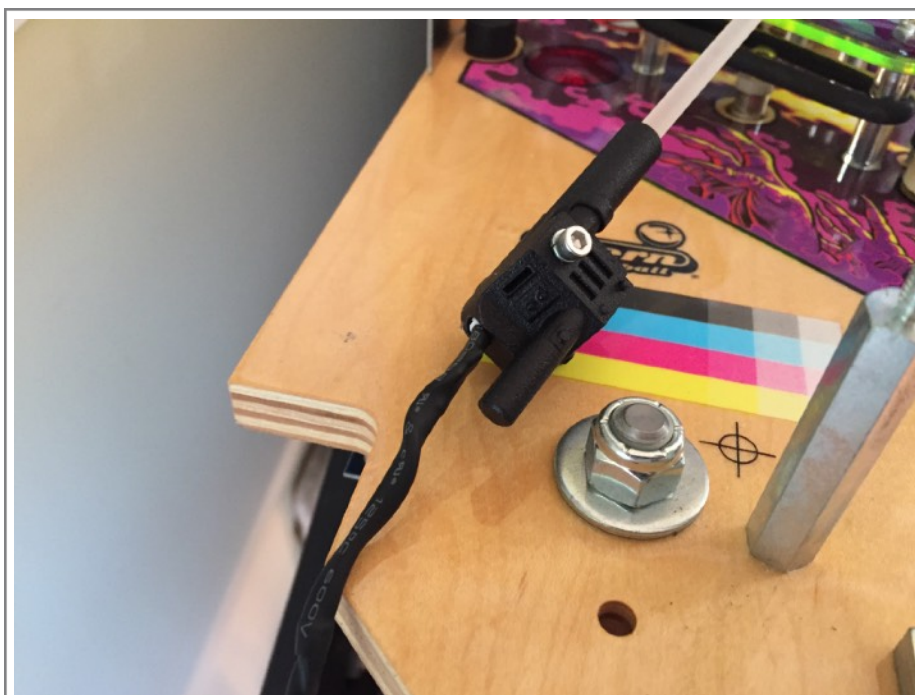

14. Fitting Proton Guns to Mechs

While the apron is off you now need to fit the proton guns to each side before securing the lighting cabling in place. Firstly the Proton Gun Streams are adjustable to extend out but are set to suit the posts in the middle position as shown. If you want to set the post in the lowest position you will need to cut the proton streams down or remove the lighting feature at the back of the gun.



Next you will have some washers that sat between the mech and the proton gun, retrieve this from when you dismantled at an earlier step and place over the pivot shaft on top of the 5mm bearing.



Have the washer with smooth and rolled edges face each other in the centre for best slide effect.

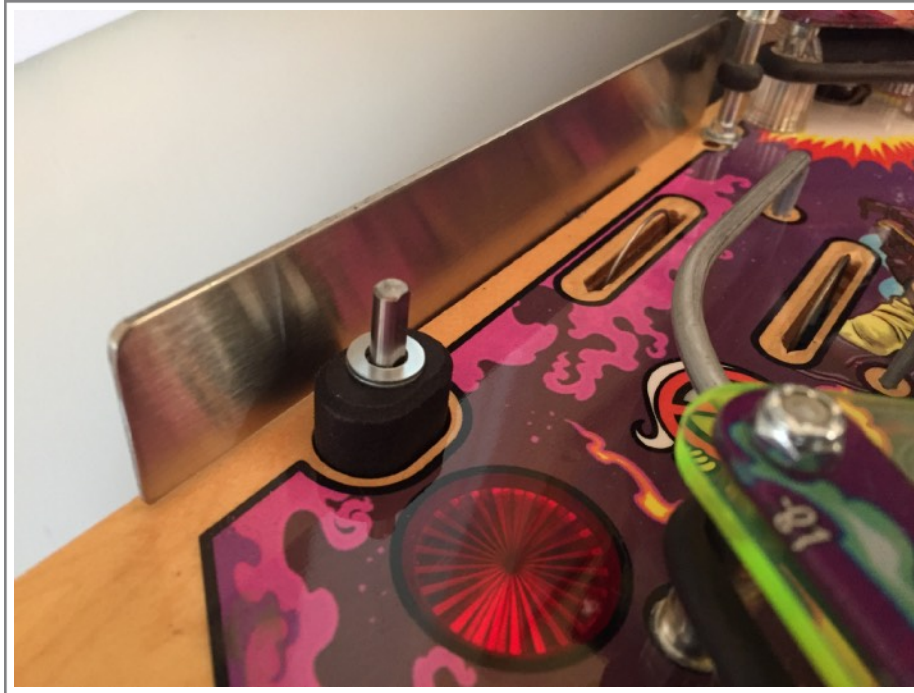

Now slide the LHS gun over the pivot shaft and have it go as low as possible and have the bolt face the flat on the drive shaft and nip up - do not tighten this super tight as you risk stripping the nylon thread. Check that the proton gun stream nozzle black component underside clears the playfield - you do not want to scratch the playfield. You should have a couple of millimetres clearance.



When you go to the RHS side, slide the RHS gun over the pivot shaft and before tightening up twist the gun across the out going lane and see if the gun hits the stainless steel rail - on our machine this rail was leaning into the RHS outlane a little. If it hits, remove the gun and use both hands to hold on to the stainless steel rail and bend the rail towards the shooter lane just a little to bring it more to a vertical position.



Now re-install the gun and do a twist check and then have it go as low as possible and have the bolt face the flat on the drive shaft and nip up - do not tighten this super tight as you risk stripping the nylon thread.



Now for the Pro route the cable around the posts and secure with a cable tie. For a game with a steel apron it won't have these posts so install a square cable tie anchor and cable tie the lighting cable and allow a little bit of movement. Perform this for both sides.



Don't be confused for the extra cable that I have there for cabin lighting for the car which passes through the hole.



I dropped the cable through this gap and then restrained to the existing cable standard-off though mine being a porto-type had some extra cable, production versions won't be as long.

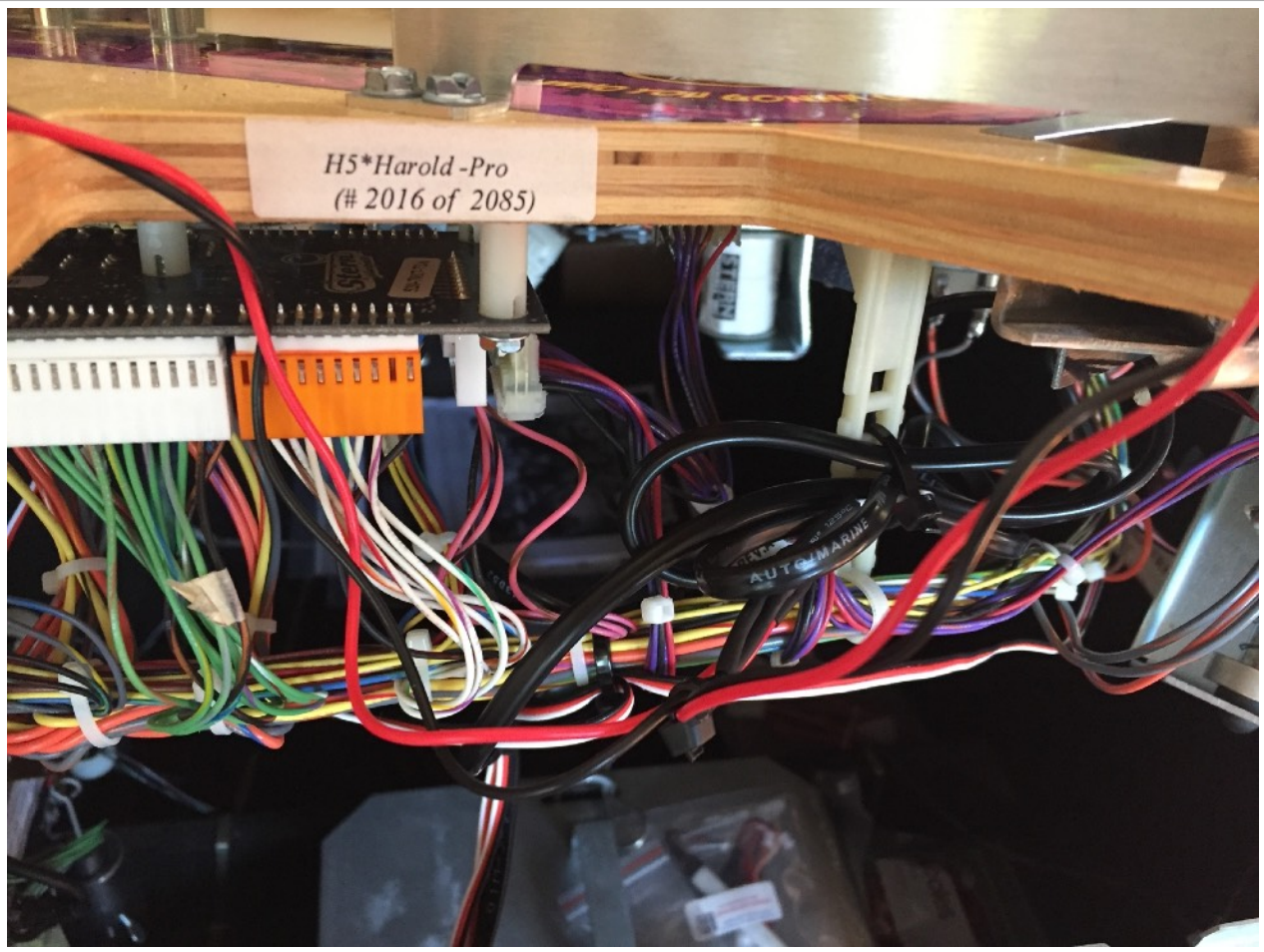

15. Connecting Cabling to Coin Door Assembly

Now we are up to connecting the Servo and Lighting cables from the guns / mechs BUT do not re-install the apron just yet.

You can now lower your playfield into it's play position and ensure no cables are at risk of being pinched.

The cabling that dropped down from Section 11 will now be in front of the coin door space.

IMPORTANT NOTE: the cabling from the playfield to the coin door assembly **DOES** have to be disconnected each time you lift the playfield unfortunately. The reason being is that currently the servo cabling is approx 1200mm / 4 foot long and to make the cable another 1800mm / approx 6ft longer to avoid disconnection is doable but introduces time delays / lag in proton gun use. The cabling will have name decals on them so you know where to fasten them plus wiring details as follows:

Make sure LHS Servo Cable goes into the LHS Servo Driver Board.

IMPORTANT NOTE: connecting to the wrong board will rotate the proton gun the wrong way on power up and could flex the acrylic stream rod to the point of breaking if you are not careful.

Line up the colour of the cable to the top 3 pins in the following order:

Brown or Black = GRD
Red or Red = VCC
Orange or White = SIG

Refer to page 20 for the Wiring Schematic.

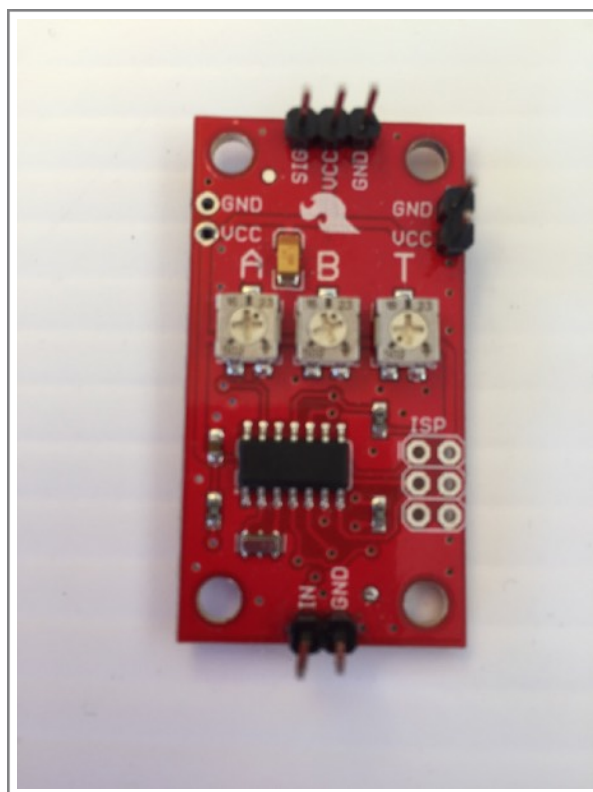

The 2 servo extension cables and proton gun led cable are bundled together and plug into the provided spots and cable. Make sure the Black wire carries up with the GRD marking on the boards. There is a large L = Left and R = Right engraved into the coin door bracket ensuring you connect to the correct side. The cables are labeled to aid in correct installation.

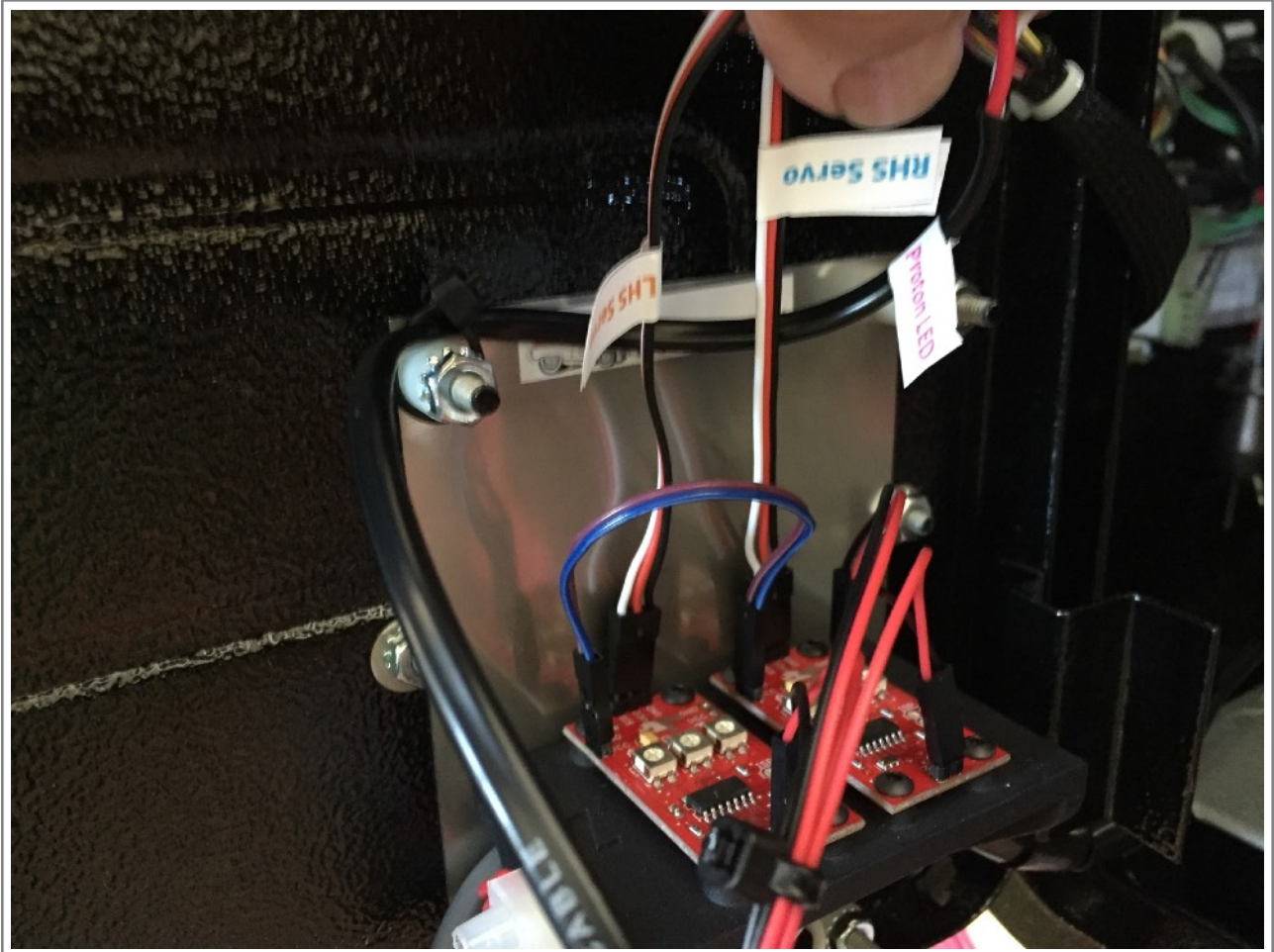

16. Understanding the Proton Gun Servo's

When I assemble the mechs here for you I attempt to get the proton gun close to it's home / rest position and also it's open / lane blocking position but you will need to fine tune your game. You will just need a Philips Screwdriver (jeweller type) and locate 3 x screw adjustable pots name A / B / T.

IMPORTANT NOTE: do not adjust these until the process is explained.

A = Home / Rest Position

B = Open / Lane Blocking Position

T = Servo Travel Speed (which is already set to max)

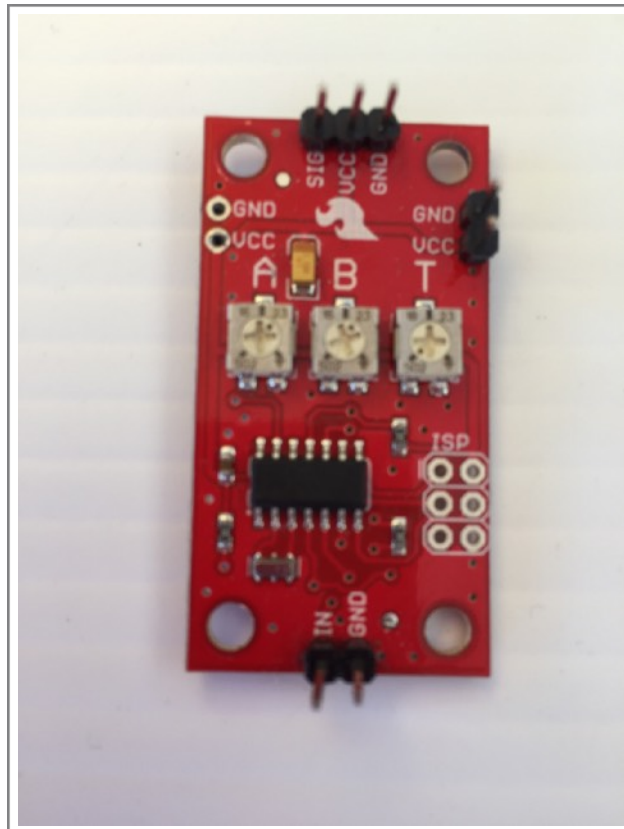

17. Hook Up / Power Up and Tune Up Process

- Now connect your power box lead that you purchased and plug into the power board and plug into the wall.
- You will notice a light on the power box go on.

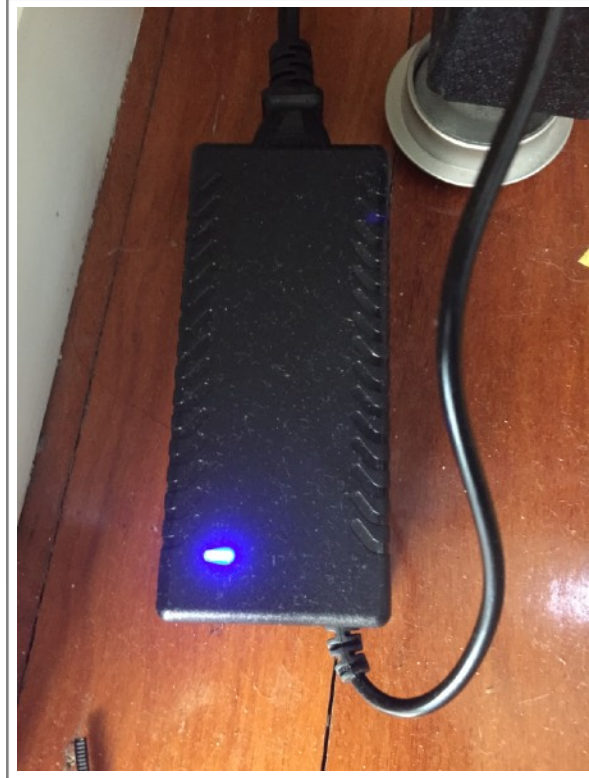

- Then go to your coin door and push the red power button and the green light will light up showing your mod is now powered and you might hear the proton gun servos move. Check your protons as they will home once powered, turn off quickly if bending to much or in the wrong direction.



- Then look at your proton guns (do not push the foot pedal just yet) and they should be fairly parallel to the stainless steel rails. Now you need to fine tune the LHS and RHS proton guns. So locate your LHS board and ever so slightly turn the “A” screw a little so the proton gun nozzle (ball stop) is about 1mm / 1/16” off the stainless steel rail and repeat for the RHS - effectively taking the proton a little beyond the vertical / parallel position.



- Once you set the home / rest point you are ready to set your activated proton guns to your liking. The idea is to set mid way between rest and the ball guide so if the ball goes to the top but it can't slip down the back (this would be a glass off situation) and out enough to stop a ball from going down the lane. Use the following photos as a guide. See next page for a closer view



- This is a closer view of the recommended left and right gun activated position but you can adjust to your liking but don't allow it to move too far to the slingshot mechs as if the ball can get past the proton gun on the outside it will get jammed and you will need to take the glass off. I recommend getting a ball out and just do a little test as a check.



- The screw on top of the proton gun locks in the acrylic rod, if you want to adjust - loosen a little and twist and then pull the stream rod, which you will have about 10mm of adjustment up only. Unfortunately while you can push the rod in it will hit the stream lighting so if you really want to push in and keep the light you need to cut the rod down.
- The guns are slightly different on each side as are the stream rod length. The visible length of the acrylic rod is:
 - LHS - 85mm
 - RHS - 80mm
- Lastly the nozzles, the part that the ball impacts is fastened to the stream acrylic rod from the underside close to the playfield (don't worry these are not that close to the playfield that it will cause damage). If these are kicked out, just loosen the bolt on top of the proton gun and twist the stream rod a fraction to get your preferred position - recommended to be vertically down.

18. Using the Proton Gun Mod

The Proton Gun Mod is very simple to use.

1. Simply push the red button on the front of the coin door and a green light will light to show you that the mod is now powered up.
2. Push the foot switch to activate the Proton Guns. Currently in the supplied mode the Proton Guns activate and swing out when the foot switch is pushed and will light up when activated. When you release the foot switch the Proton Guns swing back in to allow a ball to pass. You can do quick taps or long depressions of the foot switch and in turn the Proton Guns.
3. There is another option to modify the 2 servo PCB's by putting a solder dab in-between 2 x tabs on the underside of the board. This changes the mode so when you push the foot switch the protons activate to their full out position and return immediately to their home position after going to their maximum swing out position. Timing becomes much more important as you no longer can keep the proton guns out blocking the lane for as long as the foot switch is pressed. Refer to the next section for how to perform this change.
4. This mod is not an earned feature / mod as runs separate to the Stern System and so runs all of the time which will not be too everyone's liking. While I had ideas of how I would like to see it integrated into the game. Eg have the ball would run over each of the in-lanes (4 in total) to the flippers > charging the proton packs and pulses the red inserts near the proton guns and earns you 10 seconds of Proton Gun use from the start of your first foot switch press. I need a massive amount of interest to develop and add integration to multiple switches, an additional custom PCB etc would be an additional \$200-\$250 to an already expensive mod. It also means linking to the Stern system = higher risk of damage where currently running independently will not risk damaging any of the Node Boards. Additionally designing PCB's and programming is not my skill set so this mod would be greatly delayed to the point of not getting completed. Lastly it would mean customers would need to solder wires to various switches narrowing the potential for people to buy.

19. Modifying the Proton Gun Mod

As noted in Section 17 Item 3 this section explains how to modify the Servo PCB's to suit the Item No:3 game play mode if you want to mix it up a little.

Here is the back of the Servo PCB and here are the 2 tabs = SJ1 - Mode - simply add a solder blob across these 2 small solder tabs to change the function of the Servo Driver Board.



This is what is an example of what it looks like to change the function of the mod. Only do the SJ1-Mode - do not modify SJ2 as this will add weird effects. I did do this as a trial on the SJ1 and also had a random weird effect so it really is your choice to try and return to standard if you do not like it.



20. Trouble Shooting Possible Issues

Note: If you have come across an issue please contact Swinks via [Pinside PM](#) or my email: swinks.pinball@gmail.com and I will promptly attempt to solve the issue quickly for you and I will add the issue to this list if it is deemed helpful.

Scenario 1 - The guns are not aligned correctly from Swinks Pinball

It is highly un-likely that correct alignment will occur from us as perfect alignment depends on perfect installation as any slight angles when fastening mechs to the game will contribute to slight variance. The process of alignment is part of the insulation process - refer to Section **16. Tuning the Proton Gun Servo's** on how to tune your Proton Guns.

Scenario 2 - When adjusting the Servo PCB a Servo / Proton Gun stops working

Since the Servo PCB can be set to change the direction of the servo when the foot switch is operated there is sometimes a fine line of screw adjustment and a ever so small dead space and Swinks Pinball will do there best for your mod to not sit in this range in testing and setup from us - refer to Section **16. Tuning the Proton Gun Servo's** on how to tune your Proton Guns.

It could also be possibly if you were in at the coin door that a wire has come loose so check all plugs are seated properly and on the correct pins. If things have changed when tweaking the screw settings on the Servo PCB, there is the possible chance of being in the dead space. Worst case is to remove the mech and slightly turn the shaft held by the servo horn - refer to available assembly drawings.

Scenario 3 - The Proton Gun lighting falls out

The lighting is probably the weakest design component of the whole mod as I am trying to ensure parts are removable for servicing / adjusting and not be glued in place. The bulb is inserted into a holder and inserted into the back of the gun and held in place with just pressure. If it is a little loose cut a small piece of masking tape and wrap around the adaptor and re-insert until the friction increases to lock the bulb holder into place into the gun. Or you can add a drop of glue but may make things difficult in the future.

Scenario 4 - The Servo's have a slight buzzing sound

The buzzing sounds means that the guns in their non-used state are being restricted and not allowed to rest but are under load. This means the proton gun at rest has the proton stream section hard up against the stainless ball guides, therefore refer to Section **16. Tuning the Proton Gun Servo's** on how to tune your Proton Guns.

Scenario 5 - The Proton Streams are bending in at the home position

This means proton guns at rest are too far adjusted to the Stainless Steel rails - you need to refer to Section **16. Tuning the Proton Gun Servo's** on how to tune your Proton Guns.

It could also mean that the lock screw for the proton gun to the pivot shaft is loose or in the fastening process you did not align the end of the bolt square to the flat of the pivot shaft.

And some times it only happens on the initial power up and stream goes against the rail but on first use of the foot pedal the stream settles back to it's proper home point after it's first use - being a servo thing to accept.

Scenario 6 - Will there be spares available in the future ?

Basically - YES this will not be a mod that in a years time you can not get parts. Keeping in mind I design these mods to last and not fail early as I only want happy customers.

I will be supplying some assembly drawings soon as a point of reference to what the different parts are and how they assembly and then the following are particular outlets to get parts now to keep in stock or get down the track when needed:

- **Servo** - from Sparkfun DGServo S05NF STD

<https://www.sparkfun.com/products/14760>

- **Servo Driver PCB Boards** - from Sparkfun WIG-13118 ROHS

<https://www.sparkfun.com/products/13118>

- **3D Printed Parts** - Shapeways

[Link coming soon](#)

- **5mm Acrylic Rod** - Acrylic supplies - must be 5mm Dia. and solid. The RHS is 140mm long and LHS is 135mm long and the rod is scuffed to aid in showing the colour better.

- **LED's** - Pink 3mm Super Bright LED (3.2v) with a resistor to allow to run with 5-5.5vdc

- **Bolts, Washers, Nuts** - are all metric

21. Historical Data - Proton Gun Revisions

Swinks like statistics, as I think it is interesting to look back on & know where things are in years to come. It also may help people determine what they have once a mod is on-sold or someone buys a game with a Proton Gun Mod in it. These are the following versions:

1 x Proto-Type Proton Gun Rev 4 - white home printed version with linkages and went through a number of revisions to get it to work well. This has been parted out and home printed parts destroyed.

1 x Proto-Production V1 - RHS mech has "Swinks V1" engraved in the bracket - all black parts - direct drive and linkages no longer required. The coin door backing bracket was congested and difficult to see the boards and terminal strip - design revised for v2 release.

1-10 x Production V2 - RHS mech has "Swinks V2" engraved in the bracket - all black parts - direct drive and reduction of linkages etc. Flipped the design of the coin door backing bracket compared to v1 for easier use and minor tolerance changes across a number of parts. When made in batches of 10 this mod was **\$795 AUD** + PayPal Fee if you paid a Merchandise Payment + postage.

22. Assembly Drawings

There will be assembly drawings for the following, soon:

- LHS Gun
- RHS Gun
- LHS Mech
- RHS Mech
- Coin Door Plate

RETURN POLICY:

*Please contact us as we will be proactive to try and quickly resolve any problems from abroad reducing the need to send your purchased parts. Approval from Swinks Pinball must be granted before any items can be returned for repair or replacement. All materials, boards, cables, etc. must be included when the product is returned. We will repair or replace/exchange faulty components based on our analysis of the problem. Swinks Pinball reserves the right to deny any return or exchange. Refunds are not given. Freight Costs will **ONLY** be covered by Swinks Pinball on the return trip back to you and you cover sending it to Australia. Though in saying that we have never needed to have anything returned and very rarely experience any problems. Swinks does not issue refunds for a change of mind purchase or viewed too difficult to install. This manual was available before purchasing so you could review and aid you in feeling comfortable to purchase.*

PRODUCT DISCLAIMER:

Please remember that this is a "MOD." We took great effort in designing and testing our system in order to produce a high quality product, but it is not a factory original nor an approved part for your pinball machine. There is the risk of unwanted side effects with any modification to a factory game and there are many factors that can cause undesirable side effects after installation of such a modification. As such, we cannot assume responsibility for game malfunction, damage to the game or surroundings, unwanted electrical emissions, personal injury, or other adverse effects caused by the installation of our MOD. This mod was designed to run via an external power supply and run independent of Stern's system therefore if you opt to run via an after market power supply that plugs into the Stern boards or other aftermarket power boards say from a Pinball Parts Provider - this mod will then not be covered electrically by Swinks Pinball.

PRODUCT QUALITY DISCLAIMER:

All parts are made to the highest quality possible. Most parts are professionally 3D printed by Shapeways, iMaterialise or Zelta3D using SLS nylon / MJF nylon process with some minor print lines which is part of the process but treated to the best of our ability to make the parts look the part / professional. You may notice some minor print lines when handling but once the mod is installed they will not be clearly visible from the players perspective and give your machine that cool Ghostbuster look. Professionally printed parts are solid and stable nylon plastic prints and very strong and not hollow weak home printed parts.